

---

---

# 2020 Federal Low Income Housing Tax Credit Program

## Application For Reservation

### Deadline for Submission

#### 9% Competitive Credits

Applications Must Be Received At VHDA No Later Than **12:00 PM**  
Richmond, VA Time On **March 12, 2020**

#### Tax Exempt Bonds

Applications should be received at VHDA at least one month before the bonds are *priced* (if bonds issued by VHDA), or 75 days before the bonds are *issued* (if bonds are not issued by VHDA)



Virginia Housing Development Authority  
601 South Belvidere Street  
Richmond, Virginia 23220-6500

## INSTRUCTIONS FOR THE VIRGINIA 2020 LIHTC APPLICATION FOR RESERVATION

This application was prepared using Excel, Microsoft Office 2016. Please note that using the active Excel workbook does not eliminate the need to submit the required PDF of the signed hardcopy of the application and related documentation. A more detailed explanation of application submission requirements is provided below and in the Application Manual.

**An electronic copy of your completed application is a mandatory submission item.**

### Applications For 9% Competitive Credits

Applicants should submit an electronic copy of the application package prior to the application deadline, which is **12:00 PM** Richmond Virginia time on **March 12, 2020**. Failure to submit an electronic copy of the application by the deadline will cause the application to be disqualified.

### **Please Note:**

**Applicants should submit all application materials in electronic format only.**

**There should be distinct files which should include the following:**

- 1. Application For Reservation – the active Microsoft Excel workbook**
- 2. A PDF file which includes the following:**
  - Application For Reservation – Signed version of hardcopy
  - All application attachments (i.e. tab documents, excluding market study and plans & specs)
- 3. Market Study – PDF or Microsoft Word format**
- 4. Plans - PDF or other readable electronic format**
- 5. Specifications - PDF or other readable electronic format (may be combined into the same file as the plans if necessary)**
- 6. Unit-By-Unit work write up (rehab only) - PDF or other readable electronic format**

### **IMPORTANT:**

**VHDA only accepts files via our work center sites on Procorem. Contact [TaxCreditApps@vhda.com](mailto:TaxCreditApps@vhda.com) for access to Procorem or for the creation of a new deal workcenter. Do not submit any application materials to any email address unless specifically requested by the VHDA LIHTC Allocation Department staff.**

### Disclaimer:

VHDA assumes no responsibility for any problems incurred in using this spreadsheet or for the accuracy of calculations. Check your application for correctness and completeness before submitting the application to VHDA.

### Entering Data:

Enter numbers or text as appropriate in the blank spaces highlighted in yellow. Cells have been formatted as appropriate for the data expected. All other cells are protected and will not allow changes.

### **Please Note:**

- ▶ **VERY IMPORTANT! : Do not** use the copy/cut/paste functions within this document. Pasting fields will corrupt the application and may result in penalties. You may use links to other cells or other documents but do not paste data from one document or field to another.
- ▶ Some fields provide a dropdown of options to select from, indicated by a down arrow that appears when the cell is selected. Click on the arrow to select a value within the dropdown for these fields.
- ▶ The spreadsheet contains multiple error checks to assist in identifying potential mistakes in the application. These may appear as data is entered but are dependent on values entered later in the application. Do not be concerned with these messages until all data within the application has been entered.
- ▶ Also note that some cells contain error messages such as “#DIV/0!” as you begin. These warnings will disappear as the numbers necessary for the calculation are entered.

### Assistance:

If you have any questions, please contact the VHDA LIHTC Allocation Department. Please note that we cannot release the copy protection password.

### VHDA LIHTC Allocation Staff Contact Information

Name	Email	Phone Number
JD Bondurant	<a href="mailto: johndavid.bondurant@vhda.com">johndavid.bondurant@vhda.com</a>	(804) 343-5725
Sheila Stone	<a href="mailto: sheila.stone@vhda.com">sheila.stone@vhda.com</a>	(804) 343-5582
Stephanie Flanders	<a href="mailto: stephanie.flanders@vhda.com">stephanie.flanders@vhda.com</a>	(804) 343-5939
Phil Cunningham	<a href="mailto: philip.cunningham@vhda.com">philip.cunningham@vhda.com</a>	(804) 343-5514
Pamela Freeth	<a href="mailto: pamela.freeth@vhda.com">pamela.freeth@vhda.com</a>	(804) 343-5563
Aniyah Moaney	<a href="mailto: Aniyah.moaney@vhda.com">Aniyah.moaney@vhda.com</a>	(804) 343-5518

**TABLE OF CONTENTS**

Click on any tab label to be directed to that tab within the application.

<b>TAB</b>	<b>DESCRIPTION</b>
1. <a href="#"><u>Submission Checklist</u></a>	Mandatory Items, Tabs and Descriptions
2. <a href="#"><u>Development Information</u></a>	Development Name and Locality Information
3. <a href="#"><u>Request Info</u></a>	Credit Request Type
4. <a href="#"><u>Owner Information</u></a>	Owner Information and Developer Experience
5. <a href="#"><u>Site and Seller Information</u></a>	Site Control, Identity of Interest and Seller info
6. <a href="#"><u>Team Information</u></a>	Development Team Contact information
7. <a href="#"><u>Rehabilitation Information</u></a>	Acquisition Credits and 10-Year Look Back Info
8. <a href="#"><u>Non Profit</u></a>	Non Profit Involvement, Right of First Refusal
9. <a href="#"><u>Structure</u></a>	Building Structure and Units Description
10. <a href="#"><u>Utilities</u></a>	Utility Allowance
11. <a href="#"><u>Enhancements</u></a>	Building Amenities above Minimum Design Requirements
12. <a href="#"><u>Special Housing Needs</u></a>	504 Units, Sect. 8 Waiting List, Rental Subsidy
13. <a href="#"><u>Unit Details</u></a>	Set Aside Selection and Breakdown
14. <a href="#"><u>Budget</u></a>	Operating Expenses
15. <a href="#"><u>Project Schedule</u></a>	Actual or Anticipated Development Schedule
16. <a href="#"><u>Hard Costs</u></a>	Development Budget: Contractor Costs
17. <a href="#"><u>Owner's Costs</u></a>	Development Budget: Owner's Costs, Developer Fee, Cost Limits
18. <a href="#"><u>Eligible Basis</u></a>	Eligible Basis Calculation
19. <a href="#"><u>Sources of Funds</u></a>	Construction, Permanent, Grants and Subsidized Funding Sources
20. <a href="#"><u>Equity</u></a>	Equity and Syndication Information
20. <a href="#"><u>Gap Calculation</u></a>	Credit Reservation Amount Needed
21. <a href="#"><u>Cash Flow</u></a>	Cash Flow Calculation
22. <a href="#"><u>BINs</u></a>	BIN by BIN Eligible Basis
24. <a href="#"><u>Owner Statement</u></a>	Owner Certifications
25. <a href="#"><u>Architect's Statement</u></a>	Architect's agreement with proposed deal
26. <a href="#"><u>Scoresheet</u></a>	Self Scoresheet Calculation
27. <a href="#"><u>Development Summary</u></a>	Summary of Key Application Points
28. <a href="#"><u>Efficient Use of Resources</u></a>	Calculation of Score
29. <a href="#"><u>Efficient Use of Resources - TE Bonds</u></a>	Calculation of Score

## 2020 Low-Income Housing Tax Credit Application For Reservation

Please indicate if the following items are included with your application by putting an 'X' in the appropriate boxes. Your assistance in organizing the submission in the following order, and actually using tabs to mark them as shown, will facilitate review of your application. Please note that all mandatory items must be included for the application to be processed. The inclusion of other items may increase the number of points for which you are eligible under VHDA's point system of ranking applications, and may assist VHDA in its determination of the appropriate amount of credits that may be reserved for the development.

- |                                     |   |
|-------------------------------------|---|
| <input checked="" type="checkbox"/> | \$1,000 Application Fee <b>(MANDATORY)</b>  |
| <input checked="" type="checkbox"/> | Electronic Copy of the Microsoft Excel Based Application <b>(MANDATORY)</b>   |
| <input checked="" type="checkbox"/> | Scanned Copy of the <b>Signed</b> Tax Credit Application with Attachments (excluding market study and plans & specifications) <b>(MANDATORY)</b>              |
| <input checked="" type="checkbox"/> | Electronic Copy of the Market Study <b>(MANDATORY - Application will be disqualified if study is not submitted with application)</b>                          |
| <input checked="" type="checkbox"/> | Electronic Copy of the Plans and Unit by Unit writeup <b>(MANDATORY)</b>  |
| <input checked="" type="checkbox"/> | Electronic Copy of the Specifications <b>(MANDATORY)</b>  |
| <input checked="" type="checkbox"/> | Electronic Copy of the Existing Condition questionnaire <b>(MANDATORY if Rehab)</b>   |
| <input type="checkbox"/>            | Electronic Copy of the Physical Needs Assessment <b>(MANDATORY at reservation for a 4% rehab request)</b>   |
| <input checked="" type="checkbox"/> | Electronic Copy of Appraisal <b>(MANDATORY if acquisition credits requested)</b>  |
| <input type="checkbox"/>            | Electronic Copy of Environmental Site Assessment (Phase I) <b>(MANDATORY if 4% credits requested)</b>   |
| <input checked="" type="checkbox"/> | Tab A: Partnership or Operating Agreement, including chart of ownership structure with percentage of interests and Developer Fee Agreement <b>(MANDATORY)</b> |
| <input checked="" type="checkbox"/> | Tab B: Virginia State Corporation Commission Certification <b>(MANDATORY)</b>   |
| <input checked="" type="checkbox"/> | Tab C: Principal's Previous Participation Certification <b>(MANDATORY)</b>  |
| <input checked="" type="checkbox"/> | Tab D: List of LIHTC Developments (Schedule A) <b>(MANDATORY)</b>   |
| <input checked="" type="checkbox"/> | Tab E: Site Control Documentation & Most Recent Real Estate Tax Assessment <b>(MANDATORY)</b>   |
| <input checked="" type="checkbox"/> | Tab F: RESNET Rater Certification <b>(MANDATORY)</b>  |
| <input checked="" type="checkbox"/> | Tab G: Zoning Certification Letter <b>(MANDATORY)</b>   |
| <input checked="" type="checkbox"/> | Tab H: Attorney's Opinion <b>(MANDATORY)</b>  |
| <input checked="" type="checkbox"/> | Tab I: Nonprofit Questionnaire <b>(MANDATORY for points or pool)</b>  |
|                                     | The following documents need not be submitted unless requested by VHDA:   |
|                                     | -Nonprofit Articles of Incorporation      -IRS Documentation of Nonprofit Status  |
|                                     | -Joint Venture Agreement (if applicable)      -For-profit Consulting Agreement (if applicable)  |
| <input checked="" type="checkbox"/> | Tab J: Relocation Plan and Unit Delivery Schedule <b>(MANDATORY)</b>  |
|                                     | Tab K: Documentation of Development Location:   |
| <input checked="" type="checkbox"/> | K.1 Revitalization Area Certification   |
| <input checked="" type="checkbox"/> | K.2 Location Map  |
| <input type="checkbox"/>            | K.3 Surveyor's Certification of Proximity To Public Transportation  |
| <input type="checkbox"/>            | Tab L: PHA / Section 8 Notification Letter  |
| <input checked="" type="checkbox"/> | Tab M: Locality CEO Response Letter   |
| <input type="checkbox"/>            | Tab N: Homeownership Plan   |
| <input type="checkbox"/>            | Tab O: Plan of Development Certification Letter   |
| <input checked="" type="checkbox"/> | Tab P: Developer Experience documentation and Partnership agreements  |
| <input checked="" type="checkbox"/> | Tab Q: Documentation of Rental Assistance, Tax Abatement and/or existing RD or HUD Property   |
| <input checked="" type="checkbox"/> | Tab R: Documentation of Operating Budget and Utility Allowances   |
| <input type="checkbox"/>            | Tab S: Supportive Housing Certification   |
| <input checked="" type="checkbox"/> | Tab T: Funding Documentation  |
| <input type="checkbox"/>            | Tab U: Documentation to Request Exception to Restriction-Pools With Little/No Increase in Rent Burdened Population  |
| <input checked="" type="checkbox"/> | Tab V: Nonprofit or LHA Purchase Option or Right of First Refusal   |
| <input checked="" type="checkbox"/> | Tab W: Internet Safety Plan and Resident Information Form (if internet amenities selected)  |
| <input checked="" type="checkbox"/> | Tab X: Marketing Plan for units meeting accessibility requirements of HUD section 504   |
| <input type="checkbox"/>            | Tab Y: Inducement Resolution for Tax Exempt Bonds   |

A. GENERAL INFORMATION ABOUT PROPOSED DEVELOPMENT

Application Date: 3/12/2020

1. Development Name: Westside Village Apartments
2. Address (line 1): 2150 Sinai Road  
Address (line 2):  
City: South Boston State: VA Zip: 24592
3. If complete address is not available, provide longitude and latitude coordinates (x,y) from a location on site that your surveyor deems appropriate. Longitude: 00.00000 Latitude: 00.00000  
(Only necessary if street address or street intersections are not available.)
4. The Circuit Court Clerk's office in which the deed to the development is or will be recorded:  
City/County of Halifax County
5. The site overlaps one or more jurisdictional boundaries..... TRUE  
If true, what other City/County is the site located in besides response to #4?..... South Boston
6. Development is located in the census tract of: 9306.00
7. Development is located in a Qualified Census Tract..... TRUE
8. Development is located in a Difficult Development Area..... FALSE
9. Development is located in a Revitalization Area based on QCT ..... FALSE
10. Development is located in a Revitalization Area designated by resolution ..... TRUE
11. Development is located in an Opportunity Zone (with a binding commitment for funding)..... FALSE  
(If 9, 10 or 11 are True, Action: Provide required form in TAB K1)
12. Development is located in a census tract with a poverty rate of.....
 

	3%	10%	12%
	FALSE	FALSE	FALSE

Enter only Numeric Values below:

13. Congressional District: 5
- Planning District: 13
- State Senate District: 20
- State House District: 60

Click on the following link for assistance in determining the districts related to this development:

[Link to VHDA's HOME - Select Virginia LIHTC Reference Map](#)

14. ACTION: Provide Location Map (TAB K2)

15. Development Description: In the space provided below, give a brief description of the proposed development

Westside Village Apartments is a 70-unit, 100% project based Section 8 development serving families in South Boston, Virginia. Situated on 7.996 acres of land, the property includes eighteen brick buildings, featuring a diverse unit mix of one, two, three and four bedroom units. Westside Village Renewal LLC plans to expend over \$60,000 per unit in hard costs if awarded tax credits.

A. GENERAL INFORMATION ABOUT PROPOSED DEVELOPMENT

Application Date:

3/12/2020

16. Local Needs and Support

- a. Provide the name and the address of the chief executive officer (City Manager, Town Manager, or County Administrator of the political jurisdiction in which the development will be located:

Chief Executive Officer's Name: Tom Raab  
 Chief Executive Officer's Title: Town Manager Phone: 434-575-4200  
 Street Address: Town Hall, 455 Ferry Street  
 City: South Boston State: VA Zip: 24592

Name and title of local official you have discussed this project with who could answer questions for the local CEO: Jane Jones - Town Clerk

- b. If the development overlaps another jurisdiction, please fill in the following:

Chief Executive Officer's Name: Scott Simpson  
 Chief Executive Officer's Title: County Administrator Phone: 434-476-3300  
 Street Address: 1030 Mary Bethune Street, Suite L1  
 City: Halifax State: VA Zip: 24558

Name and title of local official you have discussed this project with who could answer questions for the local CEO: Detrick Easley - Planning & Zoning Administrator

**ACTION:** Provide Locality Notification Letter at **Tab M** if applicable.

**B. RESERVATION REQUEST INFORMATION**

1. **Requesting Credits From:**

a. If requesting 9% Credits, select credit pool:

Non Profit Pool

or

b. If requesting Tax Exempt Bonds, select development type:

[Redacted]

For Tax Exempt Bonds, where are bonds being issued?

[Redacted]

**ACTION:** Provide Inducement Resolution at **TAB Y** (if available)

2. **Type(s) of Allocation/Allocation Year**

Carryforward Allocation

Definitions of types:

a.

**Regular Allocation** means all of the buildings in the development are expected to be placed in service this calendar year, 2019.

b.

**Carryforward Allocation** means all of the buildings in the development are expected to be placed in service within two years after the end of this calendar year, 2019, but the owner will have more than 10% basis in development before the end of twelve months following allocation of credits. For those buildings, the owner requests a carryforward allocation of 2019 credits pursuant to Section 42(h)(1)(E).

3. **Select Building Allocation type:**

Acquisition/Rehab

**Note** regarding Type = Acquisition and Rehabilitation: Even if you acquired a building this year and "placed it in service" for the purpose of the acquisition credit, you cannot receive its acquisition 8609 form until the rehab 8609 is issued for that building.

4. Is this an additional allocation for a development that has buildings not yet placed in service?

FALSE

5. **Planned Combined 9% and 4% Developments**

FALSE

A site plan has been submitted with this application indicating two developments on the same or contiguous site. One development relates to this 9% allocation request and the remaining development will be a 4% tax exempt bond application. (25, 35 or 45 pts)

Name of companion development:

[Redacted]

a. Has the developer met with VHDA regarding the 4% tax exempt bond deal?

FALSE

b. List below the number of units planned for each allocation request. This stated count cannot be changed or 9% Credits will be cancelled.

Total Units within 9% allocation request? 0

Total Units within 4% Tax Exempt allocation Request? 0

Total Units: 0

% of units in 4% Tax Exempt Allocation Request: 0.00%

6. **Extended Use Restriction**

**Note:** Each recipient of an allocation of credits will be required to record an **Extended Use Agreement** as required by the IRC governing the use of the development for low-income housing for at least 30 years. Applicant waives the right to pursue a Qualified Contract.

**Must Select One:** 30

**Definition of selection:**

Development will be subject to the standard extended use agreement of 15 extended use period (after the mandatory 15-year compliance period.)

**C. OWNERSHIP INFORMATION**

NOTE: VHDA may allocate credits only to the tax-paying entity which owns the development at the time of the allocation. The term "Owner" herein refers to that entity. Please fill in the legal name of the owner. The ownership entity must be formed prior to submitting this application. Any transfer, direct or indirect, of partnership interests (except those involving the admission of limited partners) prior to the placed-in-service date of the proposed development shall be prohibited, unless the transfer is consented to by VHDA in its sole discretion. **IMPORTANT: The Owner name listed on this page must exactly match the owner name listed on the Virginia State Corporation Commission Certification.**

**1. Owner Information:**

*Must be an individual or legally formed entity.*

Owner Name: Westside Village Renewal LLC

Developer Name: Huntington Housing, Inc.

Contact: M/M ▶ Mr. First: Todd MI:  Last: Travis

Address: 11810 Grand Park Ave, Suite 600

City: North Bethesda St. ▶ MD Zip: 20852

Phone: (301) 998-0400 Ext.  Fax:

Email address: Todd@foundationhousing.com

Federal I.D. No. 84-4466826 (If not available, obtain prior to Carryover Allocation.)

Select type of entity: ▶ Limited Liability Company Formation State: ▶ VA

Additional Contact: Please Provide Name, Email and Phone number.  
Cassandra Palanza, Cassandra@foundationhousing.com, 301-998-0400

- ACTION:**
- a. Provide Owner's organizational documents (e.g. Partnership agreements and Developer Fee agreement) (Mandatory TAB A)
  - b. Provide Certification from Virginia State Corporation Commission (**Mandatory TAB B**)

**2. Principal(s) of the General Partner:** List names of individuals and ownership interest.

<u>Names **</u>	<u>Phone</u>	<u>Type Ownership</u>	<u>% Ownership</u>	
<u>Westside Village Manager LLC, Managing Member</u>	<u>301-998-0400</u>	<u>Managing Member</u>	<u>0.010%</u>	
<u>Huntington Housing, Inc., Sole Member of Managing</u>	<u>301-998-0400</u>	<u>Sole Member/Mana</u>	<u>100.000%</u>	
<u>Jason Goldblatt, Director, Huntington Housing, Inc.</u>	<u>301-998-0400</u>	<u>Nonprofit Officer</u>	<u>0.000%</u>	<i>needs</i>
<u>Gregory O'Dell, Director, Huntington Housing, Inc.</u>	<u>301-998-0400</u>	<u>Nonprofit Officer</u>	<u>0.000%</u>	<i>needs</i>
<u>Benjamin M Soto, Director, Huntington Housing, Inc.</u>	<u>301-998-0400</u>	<u>Nonprofit Officer</u>	<u>0.000%</u>	<i>needs</i>
<u>Todd Travis, President, Huntington Housing, Inc.</u>	<u>301-998-0400</u>	<u>Nonprofit Officer</u>	<u>0.000%</u>	<i>needs</i>
<u>Randall Kelly, John Parreco, Officers, Huntington Hou</u>	<u>301-998-0400</u>	<u>Nonprofit Officer</u>	<u>0.000%</u>	<i>needs</i>

The above should include 100% of the GP or LLC member interest.

\*\* These should be the names of individuals who make up the General Partnership, not simply the names of entities which may comprise those components.



**C. OWNERSHIP INFORMATION**

---

- ACTION:**
- a. Provide Principals' Previous Participation Certification (**Mandatory TAB C**)
  - b. Provide a chart of ownership structure (Org Chart) and a list of all LIHTC Developments within the last 15 years. (**Mandatory at TABS A/D**)

**3. Developer Experience:** Provide evidence that the principal or principals of the controlling general partner or managing member for the proposed development have developed:

- a. as a controlling general partner or managing member, (i) at least three tax credit developments that contain at least three times the number of housing units in the proposed development or (ii) at least six tax credit developments. .... **TRUE**

**Action:** Must be included on VHDA Experienced LIHTC Developer List or provide copies of 8609s, partnership agreements and organizational charts (**Tab P**)

- b. at least three deals as principal and have at \$500,000 in liquid assets..... **FALSE**

**Action:** Must be included on the VHDA Experienced LIHTC Developer List or provide Audited Financial Statements and copies of 8609s (**Tab P**)

- c. The development's principal(s), as a group or individually, have developed as controlling general partner or managing member, at least one tax credit development that contains at least the same number of units of this proposed development (can include Market units). .... **FALSE**

**Action:** Must provide copies of 8609s and partnership agreements (**Tab P**)

D. SITE CONTROL

**NOTE:** Site control by the Owner identified herein is a mandatory precondition of review of this application. Documentary evidence in the form of either a deed, option, purchase contract or lease for a term longer than the period of time the property will be subject to occupancy restrictions must be included herewith. (For 9% Competitive Credits - An option or contract must extend beyond the application deadline by a minimum of four months.)

**Warning:** Site control by an entity other than the Owner, even if it is a closely related party, is not sufficient. Anticipated future transfers to the Owner are not sufficient. The Owner, as identified previously, must have site control at the time this Application is submitted.

**NOTE:** If the Owner receives a reservation of credits, the property must be titled in the name of or leased by (pursuant to a long-term lease) the Owner before the allocation of credits is made.

Contact VHDA before submitting this application if there are any questions about this requirement.

1. Type of Site Control by Owner:

Applicant controls site by (select one):

Select Type:  Purchase Contract  
Expiration Date: 2/13/2022

In the Option or Purchase contract - Any contract for the acquisition of a site with an existing residential property may not require an empty building as a condition of such contract, unless relocation assistance is provided to displaced households, if any, at such level required by VHDA. See QAP for further details.

**ACTION:** Provide documentation and most recent real estate tax assessment - **Mandatory TAB E**

FALSE ..... There is more than one site for development and more than one form of site control.

(If **True**, provide documentation for each site specifying number of existing buildings on the site (if any), type of control of each site, and applicable expiration date of stated site control. A site control document is required for each site (**Tab E**.)

2. Timing of Acquisition by Owner:

Only one of the following statement should be True.

- a.  FALSE ..... Owner already controls site by either deed or long-term lease.
- b.  TRUE ..... Owner is to acquire property by deed (or lease for period no shorter than period property will be subject to occupancy restrictions) no later than..... 2/13/2022 .
- c.  FALSE ..... There is more than one site for development and more than one expected date of acquisition by Owner.

(If c is **True**, provide documentation for each site specifying number of existing buildings on the site, if any, and expected date of acquisition of each site by Owner (**Tab E**.)

**D. SITE CONTROL**

**3. Seller Information:**

Name: Westside Village Affordable LLC

Address: 11810 Grand Park Ave, Suite 600

City: North Bethesda St.: MD Zip: 20852

Contact Person: Todd Travis Phone: (301) 998-0400

There is an identity of interest between the seller and the owner/applicant..... TRUE

If above statement is **TRUE**, complete the following:

Principal(s) involved (e.g. general partners, controlling shareholders, etc.)

<u>Names</u>	<u>Phone</u>	<u>Type Ownership</u>	<u>% Ownership</u>
Echelon Housing, Inc. (EHI)		Sole Member	100.00%
Jason Goldblatt, Director, EHI		Nonprofit Officer	0.00%
Gilead Morse, Director, EHI		Nonprofit Officer	0.00%
Marc Weller, Director, EHI		Nonprofit Officer	0.00%
Todd Travis, President, EHI		Nonprofit Officer	0.00%
Robert Custer, Vice President, EHI		Nonprofit Officer	0.00%
Cassandra Palanza, Secretary, EHI		Nonprofit Officer	0.00%

*needs ownership %*  
*needs ownership %*  
*needs ownership %*  
*needs ownership %*  
*needs ownership %*  
*needs ownership %*

## 2020 Low-Income Housing Tax Credit Application For Reservation

### E. DEVELOPMENT TEAM INFORMATION

Complete the following as applicable to your development team. Provide Contact and Firm Name.

- |                          |  |                           |                               |
|--------------------------|--|---------------------------|-------------------------------|
| 1. Tax Attorney:         | <u>Craig Emden</u>   | This is a Related Entity. | <u>FALSE</u>                  |
| Firm Name:               | <u>Bocarsly Emden Cowan Esmail &amp; Arndt LLP</u>           |                           |                               |
| Address:                 | <u>7700 Old Georgetown Rd, Suite 600, Bethesda, MD 20814</u> |                           |                               |
| Email:                   | <u>cemden@bocarsly.com</u>                                   | Phone:                    | <u>301-634-0555</u>           |
| 2. Tax Accountant:       | <u>Ed Ryan</u>   | This is a Related Entity. | <u>FALSE</u>                  |
| Firm Name:               | <u>CohnReznick</u>   |                           |                               |
| Address:                 | <u>7501 Wisconsin Ave, Suite 400E</u>                        |                           |                               |
| Email:                   | <u>ed.ryan@cohnreznick.com</u>                               | Phone:                    | <u>301-652-9100</u>           |
| 3. Consultant:           | <u>Bill Curran</u>   | This is a Related Entity. | <u>FALSE</u>                  |
| Firm Name:               | <u>Chesapeake Community Advisors, Inc.</u>                   | Role:                     | <u>Development Consultant</u> |
| Address:                 | <u>33 S Gay St, Baltimore, MD 21202</u>                      |                           |                               |
| Email:                   | <u>bcurran@ccadev.com</u>                                    | Phone:                    | <u>410-685-6005</u>           |
| 4. Management Entity:    | <u>Stephanie McKinney</u>                                    | This is a Related Entity. | <u>FALSE</u>                  |
| Firm Name:               | <u>Dalcor Management</u>                                     |                           |                               |
| Address:                 | <u>650 Pratt Ave. NW, Suite B, Huntsville, AL 35801</u>      |                           |                               |
| Email:                   | <u>smckinney@dalcormgmt.com</u>                              | Phone:                    | <u>256-533-1727</u>           |
| 5. Contractor:           | <u>Tim Sherman</u>   | This is a Related Entity. | <u>FALSE</u>                  |
| Firm Name:               | <u>CH&amp;E Construction</u>                                 |                           |                               |
| Address:                 | <u>1270 Grofftown Rd, Lanacaster, PA 17602</u>               |                           |                               |
| Email:                   | <u>Tsherman@cheinc.com</u>                                   | Phone:                    | <u>717-394-0799</u>           |
| 6. Architect:            | <u>Mike Stinefelt</u>  | This is a Related Entity. | <u>FALSE</u>                  |
| Firm Name:               | <u>Studio 343</u>  |                           |                               |
| Address:                 | <u>1912 D, Lincoln Dr, Annapolis, MD 21401</u>               |                           |                               |
| Email:                   | <u>Mike@studio343.com</u>                                    | Phone:                    | <u>410-267-6589</u>           |
| 7. Real Estate Attorney: | <u>Emilie Ninan</u>  | This is a Related Entity. | <u>FALSE</u>                  |
| Firm Name:               | <u>Ballard Spahr</u>   |                           |                               |
| Address:                 | <u>1909 K Street, NW, 12th Floor, Washington, DC 20006</u>   |                           |                               |
| Email:                   | <u>ninane@ballardspahr.com</u>                               | Phone:                    | <u>302-252-4426</u>           |
| 8. Mortgage Banker:      | <u>Adam Diehl</u>  | This is a Related Entity. | <u>FALSE</u>                  |
| Firm Name:               | <u>Orix Real Estate Capital</u>                              |                           |                               |
| Address:                 | <u>1717 Main St, Suite 1100, Dallas, Texas 75201</u>         |                           |                               |
| Email:                   | <u>adam.diehl@orixrealestatecapital.com</u>                  | Phone:                    | <u>202-306-9580</u>           |
| 9. Other:                | <u></u>  | This is a Related Entity. | <u>FALSE</u>                  |
| Firm Name:               | <u></u>  | Role:                     | <u></u>                       |
| Address:                 | <u></u>  |                           |                               |
| Email:                   | <u></u>  | Phone:                    | <u></u>                       |

**F. REHAB INFORMATION**

**1. Acquisition Credit Information**

- a. Credits are being requested for existing buildings being acquired for development..... TRUE  
If no credits are being requested for existing buildings acquired for the development, skip this tab.
- b. This development has received a previous allocation of credits..... FALSE  
 If so, in what year did this development receive credits? .....
- c. The development is listed on the RD 515 Rehabilitation Priority List?..... FALSE
- d. This development is an existing RD or HUD S8/236 development..... TRUE  
**Action:** (If True, provide required form in **TAB Q**)

Note: If there is an identity of interest between the applicant and the seller in this proposal, and the applicant is seeking points in this category, then the applicant must either waive their rights to the developer's fee or other fees associated with acquisition, or obtain a waiver of this requirement from VHDA prior to application submission to receive these points.

- i. Applicant agrees to waive all rights to any developer's fee or other fees associated with acquisition..... FALSE
- ii. Applicant has obtained a waiver of this requirement from VHDA prior to the application submission deadline..... TRUE

**2. Ten-Year Rule For Acquisition Credits**

- a. All buildings satisfy the 10-year look-back rule of IRC Section 42 (d)(2)(B), including the 10% basis/\$15,000 rehab costs (\$10,000 for Tax Exempt Bonds) per unit requirement..... FALSE
- b. All buildings qualify for an exception to the 10-year rule under IRC Section 42(d)(2)(D)(i),..... FALSE
  - i. Subsection (I)..... FALSE
  - ii. Subsection (II)..... FALSE
  - iii. Subsection (III)..... FALSE
  - iv. Subsection (IV)..... FALSE
  - v. Subsection (V)..... FALSE
- c. The 10-year rule in IRC Section 42 (d)(2)(B) for all buildings does not apply pursuant to IRC Section 42(d)(6)..... TRUE
- d. There are different circumstances for different buildings..... FALSE  
**Action:** (If True, provide an explanation for each building in Tab K)

F. REHAB INFORMATION

3. Rehabilitation Credit Information

- a. Credits are being requested for rehabilitation expenditures..... TRUE
  
- b. Minimum Expenditure Requirements
  - i. All buildings in the development satisfy the rehab costs per unit requirement of IRS Section 42(e)(3)(A)(ii)..... TRUE
  - ii. All buildings in the development qualify for the IRC Section 42(e)(3)(B) exception to the 10% basis requirement (4% credit only)..... FALSE
  - iii. All buildings in the development qualify for the IRC Section 42(f)(5)(B)(ii)(II) exception..... FALSE
  - iv. There are different circumstances for different buildings..... FALSE  
**Action:** (If True, provide an explanation for each building in Tab K)

4. Request For Exception

- a. The proposed new construction development (including adaptive reuse and rehabilitation that creates additional rental space) is subject to an assessment of up to minus 20 points for being located in a pool identified by the Authority as a pool with little or no increase in rent burdened population..... FALSE
  
- b. Applicant seeks an exception to this restriction in accordance with one of the following provisions under 13VAC10-180-60:
  - i. Proposed development is specialized housing designed to meet special needs that cannot readily be addressed utilizing existing residential structures..... FALSE
  - ii. Proposed development is designed to serve as a replacement for housing being demolished through redevelopment..... FALSE
  - iii. Proposed development is housing that is an integral part of a neighborhood revitalization project sponsored by a local housing authority..... FALSE

**Action:** If any of 4(b) responses are true, provide documentation at Tab U.

**G. NONPROFIT INVOLVEMENT**

**Applications for 9% Credits** - Section must be completed in order to compete in the Non Profit tax credit pool.

**All Applicants** - Section must be completed to obtain points for nonprofit involvement.

**1. Tax Credit Nonprofit Pool Applicants:** To qualify for the nonprofit pool, an organization (described in IRC Section 501(c)(3) or 501(c)(4) and exempt from taxation under IRC Section 501(a)) should answer the following questions as TRUE:

- TRUE a. Be authorized to do business in Virginia.
- TRUE b. Be substantially based or active in the community of the development.
- TRUE c. Materially participate in the development and operation of the development throughout the compliance period (i.e., regular, continuous and substantial involvement) in the operation of the development throughout the Compliance Period.
- TRUE d. Own, either directly or through a partnership or limited liability company, 100% of the general partnership or managing member interest.
- TRUE e. Not be affiliated with or controlled by a for-profit organization.
- TRUE f. Not have been formed for the principal purpose of competition in the Non Profit Pool.
- TRUE g. Not have any staff member, officer or member of the board of directors materially participate, directly or indirectly, in the proposed development as a for profit entity.

**2. All Applicants:** To qualify for points under the ranking system, the nonprofit's involvement need not necessarily satisfy all of the requirements for participation in the nonprofit tax credit pool.

**A. Nonprofit Involvement (All Applicants)**

There is nonprofit involvement in this development..... TRUE (If false, go on to part III.)

**Action:** If there is nonprofit involvement, provide completed Non Profit Questionnaire (**Mandatory TAB I**).

**B. Type of involvement:**

Nonprofit meets eligibility requirement for points only, not pool..... FALSE

**or**

Nonprofit meets eligibility requirements for nonprofit pool and points..... TRUE

**C. Identity of Nonprofit (All nonprofit applicants):**

The nonprofit organization involved in this development is: ▶ Owner

Name: Huntington Housing, Inc. (Please fit NP name within available space)

Contact Person: Todd Travis

Street Address: 11810 Grand Park Ave, Suite 600

City: North Bethesda State: ▶ MD Zip: 20852-0000

Phone: (301) 998-0400 Extension:            Contact Email: Todd@foundationhousing

**G. NONPROFIT INVOLVEMENT**

---

D. Percentage of Nonprofit Ownership (All nonprofit applicants):

Specify the nonprofit entity's percentage ownership of the general partnership interest:

100.0%

**3. Nonprofit/Local Housing Authority Purchase Option/Right of First Refusal**

A. TRUE

After the mandatory 15-year compliance period, a qualified nonprofit or local housing authority will have the option to purchase or the right of first refusal to acquire the development for a price not to exceed the outstanding debt and exit taxes. Such debt must be limited to the original mortgage(s) unless any refinancing is approved by the nonprofit.

**Action:** Provide Option or Right of First Refusal in Recordable Form **(TAB V)**  
Provide Nonprofit Questionnaire (if applicable) **(TAB I)**

**Name of qualified nonprofit:**

Huntington Housing, Inc.

**or indicate true if Local Housing Authority**

FALSE

**Name of Local Housing Authority**

2. FALSE

A qualified nonprofit or local housing authority submits a homeownership plan committing to sell the units in the development after the mandatory 15-year compliance period to tenants whose incomes shall not exceed the applicable income limit at the time of their initial occupancy.

**Action:** Provide Homeownership Plan **(TAB N)**

**NOTE:** Applicant waives the right to pursue a Qualified Contract.



**H. STRUCTURE AND UNITS INFORMATION**

**1. General Information**

a. Total number of <b>all</b> units in development	70	bedrooms	166
Total number of <b>rental</b> units in development	70	bedrooms	166
Number of low-income rental units	70	bedrooms	166
Percentage of rental units designated low-income	100.00%		
b. Number of new units:.....	0	bedrooms	0
Number of adaptive reuse units: .....	0	bedrooms	0
Number of rehab units:.....	70	bedrooms	166
c. If any, indicate number of planned exempt units (included in total of all units in development).....			0
d. Total Floor Area For The Entire Development.....			67,160.00 <small>(Sq. ft.)</small>
e. Unheated Floor Area (i.e. Breezeways, Balconies, Storage).....			0.00 <small>(Sq. ft.)</small>
f. Nonresidential Commercial Floor Area (Not eligible for funding).....			0.00
g. Total Usable Residential Heated Area.....			67,160.00 <small>(Sq. ft.)</small>
h. Percentage of Net Rentable Square Feet Deemed To Be <b>New Rental Space</b> .....			0.00%
i. Exact area of site in acres .....	7.996		
j. Locality has approved a final site plan or plan of development.....			FALSE
If <b>True</b> , Provide required documentation ( <b>TAB O</b> ).			
k. Requirement as of 2016: Site must be properly zoned for proposed development. <b>ACTION:</b> Provide required zoning documentation ( <b>MANDATORY TAB G</b> )			
l. Development is eligible for Historic Rehab credits.....			FALSE

**Definition:**

The structure is historic, by virtue of being listed individually in the National Register of Historic Places, or due to its location in a registered historic district and certified by the Secretary of the Interior as being of historical significance to the district, and the rehabilitation will be completed in such a manner as to be eligible for historic rehabilitation tax credits.

H. STRUCTURE AND UNITS INFORMATION

2. UNIT MIX

a. Specify the average size and number per unit type (as indicated in the Architect's Certification):

Note: Average sq foot should include the prorata of common space.

Unit Type	Average Sq Foot		# of LIHTC Units	Total Rental Units
Supportive Housing	0.00	SF	0	0
1 Story Eff - Elderly	0.00	SF	0	0
1 Story 1BR - Elderly	0.00	SF	0	0
1 Story 2BR - Elderly	0.00	SF	0	0
Eff - Elderly	0.00	SF	0	0
1BR Elderly	0.00	SF	0	0
2BR Elderly	0.00	SF	0	0
Eff - Garden	0.00	SF	0	0
1BR Garden	623.00	SF	8	8
2BR Garden	859.00	SF	34	34
3BR Garden	1137.27	SF	22	22
4BR Garden	1325.00	SF	6	6
2+ Story 2BR Townhouse	0.00	SF	0	0
2+ Story 3BR Townhouse	0.00	SF	0	0
2+ Story 4BR Townhouse	0.00	SF	0	0
			70	70

Note: Please be sure to enter the values in the appropriate unit category. If not, errors will occur on the self scoresheet.

3. Structures

a. Number of Buildings (containing rental units)..... 17

b. Age of Structure:..... 43 years

c. Number of stories:..... 2

d. The development is a scattered site development..... FALSE

e. Commercial Area Intended Use: \_\_\_\_\_

f. Development consists primarily of: (Only One Option Below Can Be True)

i. Low Rise Building(s) - (1-5 stories with <u>any</u> structural elements made of wood).....	<u>TRUE</u>
ii. Mid Rise Building(s) - (5-7 stories with <u>no</u> structural elements made of wood).....	<u>FALSE</u>
iii. High Rise Building(s) - (8 or more stories with <u>no</u> structural elements made of wood).....	<u>FALSE</u>

**H. STRUCTURE AND UNITS INFORMATION**

g. Indicate **True** for all development's structural features that apply:

i. Row House/Townhouse	<u>TRUE</u>	v. Detached Single-family	<u>FALSE</u>
ii. Garden Apartments	<u>TRUE</u>	vi. Detached Two-family	<u>FALSE</u>
iii. Slab on Grade	<u>TRUE</u>	vii. Basement	<u>FALSE</u>
iv. Crawl space	<u>FALSE</u>		

h. Development contains an elevator(s).	<u>FALSE</u>
If true, # of Elevators.	<u>0</u>
Elevator Type (if known)	<u></u>

i. Roof Type	▶ <u>Pitched</u>
j. Construction Type	▶ <u>Frame</u>
k. Primary Exterior Finish	▶ <u>Brick</u>

**4. Site Amenities (indicate all proposed)**

a. Business Center.....	<u>PROPOSED</u>	f. Limited Access.....	<u>FALSE</u>
b. Covered Parking.....	<u>FALSE</u>	g. Playground.....	<u>PROPOSED</u>
c. Exercise Room.....	<u>FALSE</u>	h. Pool.....	<u>FALSE</u>
d. Gated access to Site.....	<u>FALSE</u>	i. Rental Office.....	<u>TRUE</u>
e. Laundry facilities.....	<u>TRUE</u>	j. Sports Activity Ct..	<u>TRUE</u>
		k. Other:	<u></u>

l. Describe Community Facilities:	<u>Laundry Room, Rental Office, Basketball Court</u>
-----------------------------------	--

m. Number of Proposed Parking Spaces.....	<u>118</u>
Parking is shared with another entity .....	<u>FALSE</u>

n. Development located within 1/2 mile of an existing commuter rail, light rail or subway station or 1/4 mile from existing public bus stop. ....	<u>FALSE</u>
---	--------------

If **True**, Provide required documentation (**TAB K3**).

**H. STRUCTURE AND UNITS INFORMATION**

---

**5. Plans and Specifications**

**a. Minimum submission requirements for all properties (new construction, rehabilitation and adaptive reuse):**

- i. A location map with development clearly defined.
- ii. Sketch plan of the site showing overall dimensions of all building(s), major site elements (e.g., parking lots and location of existing utilities, and water, sewer, electric, gas in the streets adjacent to the site). Contour lines and elevations are not required.
- iii. Sketch plans of all building(s) reflecting overall dimensions of:
  - a. Typical floor plan(s) showing apartment types and placement
  - b. Ground floor plan(s) showing common areas
  - c. Sketch floor plan(s) of typical dwelling unit(s)
  - d. Typical wall section(s) showing footing, foundation, wall and floor structureNotes must indicate basic materials in structure, floor and exterior finish.

**b. The following are due at reservation for Tax Exempt 4% Applications and at allocation for 9% Applications.**

- i. Phase I environmental assessment.
- ii. Physical needs assessment for any rehab only development.

**NOTE:** All developments must meet VHDA's **Minimum Design and Construction Requirements**. By signing and submitting the Application for Reservation of LIHTC, the applicant certifies that the proposed project budget, plans & specifications and work write-ups incorporate all necessary elements to fulfill these requirements.

**6. Market Study Data:**

Obtain the following information from the **Market Study** conducted in connection with this tax credit application:

Project Wide Capture Rate - LIHTC Units	5.40%
Project Wide Capture Rate - Market Units	NA
Project Wide Capture Rate - All Units	5.40%
Project Wide Absorption Period (Months)	NA

J. ENHANCEMENTS

Each development must meet the following baseline energy performance standard applicable to the development's construction category.

- a. **New Construction:** must meet all criteria for EPA EnergyStar certification.
- b. **Rehabilitation:** renovation must result in at least a 30% performance increase or score an 80 or lower on the HERS Index.
- c. **Adaptive Reuse:** must score a 95 or lower on the HERS Index.

Certification and HERS Index score must be verified by a third-party, independent, non-affiliated, certified RESNET home energy rater.

Indicate **True** for the following items that apply to the proposed development:

**ACTION:** Provide RESNET rater certification (**TAB F**)

**ACTION:** Provide Internet Safety Plan and Resident Information Form (Tab W) if options selected below.

1. For any development, upon completion of construction/rehabilitation:

- TRUE a. A community/meeting room with a minimum of 749 square feet is provided.
- 85.00% b. Percentage of brick or other similar low-maintenance material approved by the Authority covering the exterior walls. Community buildings are to be included in percentage calculations.
- TRUE c. Water expense is sub-metered (the tenant will pay monthly or bi-monthly bill).  
**Error: Owner should not pay water on Utilities if submetered.**
- FALSE d. All faucets, toilets and showerheads in each bathroom are WaterSense labeled products.
- TRUE e. Each unit is provided with the necessary infrastructure for high-speed internet/broadband service.
- TRUE f. Free WiFi access will be provided in community room for resident only usage.
- FALSE g. Each unit is provided free individual high speed internet access.
- or
- TRUE h. Each unit is provided free individual WiFi access.
- TRUE i. Full bath fans are wired to primary light with delayed timer or has continuous exhaust by ERV/DOAS.
- or
- FALSE j. Full bath fans are equipped with a humidistat.
- TRUE k. Cooking surfaces are equipped with fire prevention features
- or
- FALSE l. Cooking surfaces are equipped with fire suppression features.
- FALSE m. Rehab only: Each unit has dedicated space, drain and electrical hook-ups to accept a permanently installed dehumidification system.
- or
- TRUE n. All Construction types: each unit is equipped with a permanent dehumidification system.
- TRUE o. All interior doors within units are solid core.
- TRUE p. Every kitchen, living room and bedroom contains, at minimum, one USB charging port.
- TRUE q. All kitchen light fixtures are LED and meet MDCR lighting guidelines.
- TRUE r. Each unit has a shelf or ledge outside the primary entry door located in an interior hallway.
- FALSE s. New construction only: Each unit to have balcony or patio with a minimum depth of 5 feet clear from face of building and a minimum size of 30 square feet.

**For all developments exclusively serving elderly tenants upon completion of construction/rehabilitation:**

J. ENHANCEMENTS

For all developments exclusively serving elderly tenants upon completion of construction/rehabilitation:

- FALSE a. All cooking ranges have front controls.
- FALSE b. Bathrooms have an independent or supplemental heat source.
- FALSE c. All entrance doors have two eye viewers, one at 42" inches and the other at standard height.

2. Green Certification

- a. Applicant agrees to meet the base line energy performance standard applicable to the development's construction category as listed above.

The applicant will also obtain one of the following:

- |                                |  |                                |  |
|--------------------------------|--|--------------------------------|--|
| <input type="checkbox"/> TRUE  | Earthcraft Gold or higher certification        | <input type="checkbox"/> FALSE | National Green Building Standard (NGBS) certification of Silver or higher. |
| <input type="checkbox"/> FALSE | U.S. Green Building Council LEED certification | <input type="checkbox"/> FALSE | Enterprise Green Communities (EGC) Certification                           |

**Action:** If seeking any points associated Green certification, provide appropriate documentation at **TAB F**.

- b. Applicant will pursue one of the following certifications to be awarded points on a future development application. (Failure to reach this goal will not result in a penalty.)

- |                                |                                     |                                |                         |
|--------------------------------|-------------------------------------|--------------------------------|-------------------------|
| <input type="checkbox"/> FALSE | Zero Energy Ready Home Requirements | <input type="checkbox"/> FALSE | Passive House Standards |
|--------------------------------|-------------------------------------|--------------------------------|-------------------------|

3. Universal Design - Units Meeting Universal Design Standards (units must be shown on Plans)

- TRUE a. Architect of record certifies that units will be constructed to meet VHDA's Universal Design standards.
- 7 b. Number of Rental Units constructed to meet VHDA's Universal Design standards:  
 10% % of Total Rental Units

- 4.  FALSE Market-rate units' amenities are substantially equivalent to those of the low income units.

If not, please explain: No market-rate units are present

 Architect of Record initial here that the above information is accurate per certification statement within this application.

**I. UTILITIES**

1. Utilities Types:

- a. Heating Type Electric Forced Air
- b. Cooking Type Electric
- c. AC Type Central Air
- d. Hot Water Type Electric

2. Indicate True if the following services will be included in Rent:

- |                 |              |                      |              |
|-----------------|--------------|----------------------|--------------|
| Water?.....     | <u>TRUE</u>  | Heat?.....           | <u>FALSE</u> |
| Hot Water?..... | <u>FALSE</u> | AC?.....             | <u>FALSE</u> |
| Lighting?.....  | <u>FALSE</u> | Sewer?.....          | <u>TRUE</u>  |
| Cooking? .....  | <u>FALSE</u> | Trash Removal? ..... | <u>TRUE</u>  |

Utilities	Enter Allowances by Bedroom Size				
	0-BR	1-BR	2-BR	3-BR	4-BR
Heating	0	62	95	113	135
Air Conditioning	0	0	0	0	0
Cooking	0	0	0	0	0
Lighting	0	0	0	0	0
Hot Water	0	0	0	0	0
Water	0	0	0	0	0
Sewer	0	0	0	0	0
Trash	0	0	0	0	0
Total utility allowance for costs paid by tenant	\$0	\$62	\$95	\$113	\$135

3. The following sources were used for Utility Allowance Calculation (Provide documentation **TAB R**).

- a. TRUE HUD
- b. FALSE Utility Company (Estimate)
- c. FALSE Utility Company (Actual Survey)
- d. FALSE Local PHA
- e. FALSE Other: \_\_\_\_\_

**Warning:** The VHDA housing choice voucher program utility schedule shown on VHDA.com should not be used unless directed to do so by the local housing authority.

**K. SPECIAL HOUSING NEEDS**

**NOTE:** Any Applicant commits to providing first preference to members of targeted populations having state rental assistance and will not impose any eligibility requirements or lease terms for such individuals that are more restrictive than its standard requirements and terms, the terms of the MOU establishing the target population, or the eligibility requirements for the state rental assistance.

1. **Accessibility:** Indicate **True** for the following point categories, as appropriate.

**Action:** Provide appropriate documentation (**Tab X**)

TRUE

- a. Any development in which (i) the greater of 5 units or 10% of units will be assisted by HUD project-based vouchers (as evidenced by the submission of a letter satisfactory to the Authority from an authorized public housing authority (PHA) that the development meets all prerequisites for such assistance), or another form of documented and binding federal project-based rent subsidies in order to ensure occupancy by extremely low-income persons. Locality project based rental subsidy meets the definition of state project based rental subsidy;
- (ii) will conform to HUD regulations interpreting the accessibility requirements of section 504 of the Rehabilitation Act; and be actively marketed to persons with disabilities as defined in the Fair Housing Act in accordance with a plan submitted as part of the application for credits.
- (iii) above must include roll-in showers, roll under sinks and front control ranges, unless agreed to by the Authority prior to the applicant's submission of its application.

Documentation from source of assistance must be provided with the application.

**Note:** Subsidies may apply to any units, not only those built to satisfy Section 504.  
(60 points)

FALSE

- b. Any development in which the greater of 5 units or 10% of the units (i) have rents within HUD's Housing Choice Voucher ("HCV") payment standard; (ii) conform to HUD regulations interpreting the accessibility requirements of section 504 of the Rehabilitation Act; and (iii) are actively marketed to persons with disabilities as defined in the Fair Housing Act in accordance with a plan submitted as part of the application for credits (30 points)

FALSE

- c. Any development in which 5% of the units (i) conform to HUD regulations interpreting the accessibility requirements of section 504 of the Rehabilitation Act and (ii) are actively marketed to persons with disabilities as defined in the Fair Housing Act in accordance with a plan submitted as part of this application for credits. (15 points)

**For items a,b or c, all common space must also conform to HUD regulations interpreting the accessibility requirements of section 504 of the Rehabilitation Act.**

 **Architect of Record initial here that the above information is accurate per certification statement within this application.**



K. SPECIAL HOUSING NEEDS

2. Special Housing Needs/Leasing Preference:

a. If not general population, select applicable special population:

- FALSE Elderly (as defined by the United States Fair Housing Act.)
- FALSE Persons with Disabilities (must meet the requirements of the Federal Americans with Disabilities Act) - Accessible Supportive Housing Pool only
- FALSE Supportive Housing (as described in the Tax Credit Manual)

**Action:** Provide Permanent Supportive Housing Certification (Tab S)

b. The development has existing tenants and a relocation plan has been developed..... TRUE

(If True, VHDA policy requires that the impact of economic and/or physical displacement on those tenants be minimized, in which Owners agree to abide by the Authority's Relocation Guidelines for LIHTC properties.)

**Action:** Provide Relocation Plan and Unit Delivery Schedule (Mandatory if tenants are displaced - Tab J)

3. Leasing Preferences

a. Will leasing preference be given to applicants on a public housing waiting list and/or Section 8 waiting list? select: No

Organization which holds waiting list: \_\_\_\_\_

Contact person: \_\_\_\_\_

Title: \_\_\_\_\_

Phone Number \_\_\_\_\_

**Action:** Provide required notification documentation (TAB L)

b. Leasing preference will be given to individuals and families with children..... TRUE

(Less than or equal to 20% of the units must have of 1 or less bedrooms).

c. Specify the number of low-income units that will serve individuals and families with children by providing three or more bedrooms: 28

% of total Low Income Units 40%

**NOTE:** Development must utilize a **VHDA Certified Management Agent**. Proof of management certification must be provided before 8609s are issued.

**K. SPECIAL HOUSING NEEDS**

**4. Rental Assistance**

a. Some of the low-income units do or will receive rental assistance..... TRUE

b. Indicate True if rental assistance will be available from the following

FALSE Rental Assistance Demonstration (RAD) or other PHA conversion to based rental assistance.

FALSE Section 8 New Construction Substantial Rehabilitation

FALSE Section 8 Moderate Rehabilitation

FALSE Section 8 Certificates

TRUE Section 8 Project Based Assistance

FALSE RD 515 Rental Assistance

FALSE Section 8 Vouchers

FALSE State Assistance

FALSE Other: \_\_\_\_\_

c. The Project Based vouchers above are applicable to the 30% units seeking points. FALSE

i. If True above, how many of the 30% units will not have project based vouchers? \_\_\_\_\_

d. Number of units receiving assistance:	70
How many years in rental assistance contract?	20.00
Expiration date of contract:	11/30/2037
There is an Option to Renew.....	TRUE

**Action:** Contract or other agreement provided **(TAB Q)**.

**L. UNIT DETAILS**

**1. Set-Aside Election: UNITS SELECTED IN INCOME AND RENT DETERMINE POINTS FOR THE BONUS POINT CATEGORY**

Note: In order to qualify for any tax credits, a development must meet one of two minimum threshold occupancy tests. Either (i) at least 20% of the units must be rent-restricted and occupied by persons whose incomes are 50% or less of the area median income adjusted for family size (this is called the 20/50 test) or (ii) at least 40% of the units must be rent-restricted and occupied by persons whose incomes are 60% or less of the area median income adjusted for family size (this is called the 40/60 test), all as described in Section 42 of the IRC. Rent-and income-restricted units are known as low-income units. If you have more low-income units than required, you qualify for more credits. If you serve lower incomes than required, you receive more points under the ranking system.

**a. Units Provided Per Household Type:**

Income Levels			Avg Inc.
# of Units	% of Units		
0	0.00%	20% Area Median	
0	0.00%	30% Area Median	
28	40.00%	40% Area Median	
0	0.00%	50% Area Median	
42	60.00%	60% Area Median	
0	0.00%	70% Area Median	
0	0.00%	80% Area Median	
0	0.00%	Market Units	
70	100.00%	<b>Total</b>	

Rent Levels			Avg Inc.
# of Units	% of Units		
0	0.00%	20% Area Median	
0	0.00%	30% Area Median	
42	60.00%	40% Area Median	
0	0.00%	50% Area Median	
28	40.00%	60% Area Median	
0	0.00%	70% Area Median	
0	0.00%	80% Area Median	
0	0.00%	Market Units	
70	100.00%	<b>Total</b>	

- b. The development plans to utilize average income..... FALSE  
 If true, should the points based on the units assigned to the levels above be waived and therefore not required for compliance?  
 20-30% Levels FALSE 40% Levels FALSE 50% levels FALSE

**2. Unit Detail FOR YOUR CONVENIENCE, COPY AND PASTE IS ALLOWED WITHIN UNIT MIX GRID**

In the following grid, add a row for each unique unit type planned within the development. Enter the appropriate data for both tax credit and market rate units.

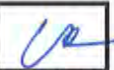
 Architect of Record initial here that the information below is accurate per certification statement within this application.

	Unit Type (Select One)	Rent Target (Select One)	Number of Units	# of Units 504 compliant	Net Rentable Square Feet	Monthly Rent Per Unit	Total Monthly Rent
Mix 1	1 BR - 1 Bath	40% AMI	4	2	623.00	\$485.00	\$1,940
Mix 2	1 BR - 1 Bath	60% AMI	4		623.00	\$485.00	\$1,940
Mix 3	2 BR - 1 Bath	40% AMI	22		853.00	\$565.00	\$12,430
Mix 4	2 BR - 1 Bath	60% AMI	6		853.00	\$565.00	\$3,390
Mix 5	2 BR - 1 Bath	60% AMI	3	3	810.00	\$565.00	\$1,695
Mix 6	2 BR - 1 Bath	60% AMI	3		964.00	\$565.00	\$1,695
Mix 7	3 BR - 1 Bath	40% AMI	12		1128.00	\$738.00	\$8,856
Mix 8	3 BR - 1 Bath	60% AMI	7		1128.00	\$738.00	\$5,166
Mix 9	3 BR - 1 Bath	60% AMI	1	1	1082.00	\$738.00	\$738
Mix 10	3 BR - 1 Bath	60% AMI	2		1253.00	\$738.00	\$1,476
Mix 11	4 BR - 2 Bath	40% AMI	4		1334.00	\$781.00	\$3,124
Mix 12	4 BR - 2 Bath	60% AMI	1		1334.00	\$781.00	\$781
Mix 13	4 BR - 2 Bath	60% AMI	1	1	1280.00	\$781.00	\$781
Mix 14							\$0
Mix 15							\$0
Mix 16							\$0

L. UNIT DETAILS

Mix 17								\$0
Mix 18								\$0
Mix 19								\$0
Mix 20								\$0
Mix 21								\$0
Mix 22								\$0
Mix 23								\$0
Mix 24								\$0
Mix 25								\$0
Mix 26								\$0
Mix 27								\$0
Mix 28								\$0
Mix 29								\$0
Mix 30								\$0
Mix 31								\$0
Mix 32								\$0
Mix 33								\$0
Mix 34								\$0
Mix 35								\$0
Mix 36								\$0
Mix 37								\$0
Mix 38								\$0
Mix 39								\$0
Mix 40								\$0
Mix 41								\$0
Mix 42								\$0
Mix 43								\$0
Mix 44								\$0
Mix 45								\$0
Mix 46								\$0
Mix 47								\$0
Mix 48								\$0
Mix 49								\$0
Mix 50								\$0
Mix 51								\$0
Mix 52								\$0
Mix 53								\$0
Mix 54								\$0
Mix 55								\$0
Mix 56								\$0
Mix 57								\$0
Mix 58								\$0
Mix 59								\$0
Mix 60								\$0
Mix 61								\$0
Mix 62								\$0
Mix 63								\$0
Mix 64								\$0
Mix 65								\$0
Mix 66								\$0
Mix 67								\$0
Mix 68								\$0
Mix 69								\$0
Mix 70								\$0
Mix 71								\$0
Mix 72								\$0

2020 Low-Income Housing Tax Credit Application For Reservation

L. UNIT DETAILS

Mix 73								\$0
Mix 74								\$0
Mix 75								\$0
Mix 76								\$0
Mix 77								\$0
Mix 78								\$0
Mix 79								\$0
Mix 80								\$0
Mix 81								\$0
Mix 82								\$0
Mix 83								\$0
Mix 84								\$0
Mix 85								\$0
Mix 86								\$0
Mix 87								\$0
Mix 88								\$0
Mix 89								\$0
Mix 90								\$0
Mix 91								\$0
Mix 92								\$0
Mix 93								\$0
Mix 94								\$0
Mix 95								\$0
Mix 96								\$0
Mix 97								\$0
Mix 98								\$0
Mix 99								\$0
Mix 100								\$0
<b>TOTALS</b>			70	7				\$44,012

<b>Total Units</b>	<b>70</b>	<b>Net Rentable SF:</b>	<b>TC Units</b>	<b>67,160.00</b>
			<b>MKT Units</b>	<b>0.00</b>
			<b>Total NR SF:</b>	<b>67,160.00</b>

<b>Floor Space Fraction (to 7 decimals)</b>	<b>100.00000%</b>
---	-------------------

2020 Low-Income Housing Tax Credit Application For Reservation

M. OPERATING EXPENSES

**Administrative:**

Use Whole Numbers Only!

1. Advertising/Marketing			\$22,728
2. Office Salaries			\$92,670
3. Office Supplies			\$12,800
4. Office/Model Apartment	(type _____)		\$0
5. Management Fee			\$22,752
<u>4.50%</u> of EGI	<u>\$325.03</u>	Per Unit	
6. Manager Salaries			\$0
7. Staff Unit (s)	(type _____)		\$0
8. Legal			\$1,200
9. Auditing			\$5,000
10. Bookkeeping/Accounting Fees			\$830
11. Telephone & Answering Service			\$0
12. Tax Credit Monitoring Fee			\$0
13. Miscellaneous Administrative			\$2,532
<b>Total Administrative</b>			<b>\$160,512</b>

**Utilities**

14. Fuel Oil			\$0
15. Electricity			\$16,801
16. Water			\$14,655
17. Gas			\$0
18. Sewer			\$27,778
<b>Total Utility</b>			<b>\$59,234</b>

**Operating:**

19. Janitor/Cleaning Payroll			\$22,400
20. Janitor/Cleaning Supplies			\$8,158
21. Janitor/Cleaning Contract			\$0
22. Exterminating			\$2,200
23. Trash Removal			\$6,813
24. Security Payroll/Contract			\$0
25. Grounds Payroll			\$0
26. Grounds Supplies			\$8,600
27. Grounds Contract			\$0
28. Maintenance/Repairs Payroll			\$0
29. Repairs/Material			\$6,200
30. Repairs Contract			\$0
31. Elevator Maintenance/Contract			\$0
32. Heating/Cooling Repairs & Maintenance			\$0
33. Pool Maintenance/Contract/Staff			\$0
34. Snow Removal			\$1,800
35. Decorating/Payroll/Contract			\$0
36. Decorating Supplies			\$0
37. Miscellaneous			\$0
<b>Totals Operating &amp; Maintenance</b>			<b>\$56,171</b>

**M. OPERATING EXPENSES**

**Taxes & Insurance**

38. Real Estate Taxes	\$20,253
39. Payroll Taxes	\$10,576
40. Miscellaneous Taxes/Licenses/Permits	\$9,003
41. Property & Liability Insurance	\$9,677
42. Fidelity Bond	\$0
43. Workman's Compensation	\$0
44. Health Insurance & Employee Benefits	\$0
45. Other Insurance	\$0
<b>Total Taxes &amp; Insurance</b>	<b>\$49,509</b>

<b>Total Operating Expense</b>	<b>\$325,426</b>
--------------------------------	------------------

<b>Total Operating Expenses Per Unit</b>	\$4,649	<b>C. Total Operating Expenses as % of EGI</b>	64.39%
--	---------	--	--------

<b>Replacement Reserves</b> (Total # Units X \$300 or \$250 New Const. Elderly Minimum)	<b>\$21,000</b>
---	-----------------

<b>Total Expenses</b>	<b>\$346,426</b>
-----------------------	------------------

**ACTION:** Provide Documentation of Operating Budget at **Tab R** if applicable.

2020 Low-Income Housing Tax Credit Application For Reservation

N. PROJECT SCHEDULE

ACTIVITY	ACTUAL OR ANTICIPATED DATE	NAME OF RESPONSIBLE PERSON
<b>1. SITE</b>		
a. Option/Contract	2/13/2020	John Parreco
b. Site Acquisition	2/13/2020	John Parreco
c. Zoning Approval	2/3/2020	N/A
d. Site Plan Approval	N/A	N/A
<b>2. Financing</b>		
<b>a. Construction Loan</b>		
i. Loan Application	N/A	N/A
ii. Conditional Commitment	N/A	N/A
iii. Firm Commitment	N/A	N/A
<b>b. Permanent Loan - First Lien</b>		
i. Loan Application	6/1/2020	Adam Diehl
ii. Conditional Commitment	9/1/2020	Adam Diehl
iii. Firm Commitment	11/1/2020	Adam Diehl
<b>c. Permanent Loan-Second Lien</b>		
i. Loan Application	N/A	N/A
ii. Conditional Commitment	N/A	N/A
iii. Firm Commitment	N/A	N/A
<b>d. Other Loans &amp; Grants</b>		
i. Type & Source, List	Seller Note at Closing	Todd Travis
ii. Application		
iii. Award/Commitment		
<b>2. Formation of Owner</b>	1/27/2020	N/A
<b>3. IRS Approval of Nonprofit Status</b>	1/17/1995	N/A
<b>4. Closing and Transfer of Property to Owner</b>	12/1/2020	Todd Travis
<b>5. Plans and Specifications, Working Drawings</b>	2/17/2020	Mike Stinefelt
<b>6. Building Permit Issued by Local Government</b>	11/1/2020	Tim Sherman
<b>7. Start Construction</b>	2/1/2021	Tim Sherman
<b>8. Begin Lease-up</b>	3/1/2021	Stephanie McKinney
<b>9. Complete Construction</b>	12/31/2021	Tim Sherman
<b>10. Complete Lease-Up</b>	12/31/2021	Stephanie McKinney
<b>11. Credit Placed in Service Date</b>	12/31/2021	Todd Travis



**2020 Low-Income Housing Tax Credit Application For Reservation**

**O. PROJECT BUDGET - HARD COSTS**

**Cost/Basis/Maximum Allowable Credit**

Complete cost column and basis column(s) as appropriate

Note: Attorney must opine, among other things, as to correctness of the inclusion of each cost item in eligible basis, type of credit and numerical calculations included in Project Budget.

Item	(A) Cost	Amount of Cost up to 100% Includable in Eligible Basis--Use Applicable Column(s):		
		"30% Present Value Credit"		(D)
		(B) Acquisition	(C) Rehab/ New Construction	"70 % Present Value Credit"
<b>1. Contractor Cost</b>				
a. Unit Structures (New)	0	0	0	0
b. Unit Structures (Rehab)	3,837,730	0	0	3,837,730
c. Non Residential Structures	0	0	0	0
d. Commercial Space Costs	0	0	0	0
e. Structured Parking Garage	0	0	0	0
<b>Total Structure</b>	3,837,730	0	0	3,837,730
f. Earthwork	0	0	0	0
g. Site Utilities	0	0	0	0
h. Roads & Walks	0	0	0	0
i. Site Improvements	0	0	0	0
j. Lawns & Planting	0	0	0	0
k. Engineering	0	0	0	0
l. Off-Site Improvements	0	0	0	0
m. Site Environmental Mitigation	0	0	0	0
n. Demolition	0	0	0	0
o. Site Work	0	0	0	0
p. Other Site work	0	0	0	0
<b>Total Land Improvements</b>	0	0	0	0
<b>Total Structure and Land</b>	3,837,730	0	0	3,837,730
q. General Requirements	230,260	0	0	230,260
r. Builder's Overhead ( 2.0% Contract)	76,750	0	0	76,750
s. Builder's Profit ( 6.0% Contract)	230,260	0	0	230,260
t. Bonds	0	0	0	0
u. Building Permits	0	0	0	0
v. Special Construction	0	0	0	0
w. Special Equipment	0	0	0	0
x. Other 1: _____	0	0	0	0
y. Other 2: _____	0	0	0	0
z. Other 3: _____	0	0	0	0
<b>Contractor Costs</b>	<b>\$4,375,000</b>	<b>\$0</b>	<b>\$0</b>	<b>\$4,375,000</b>

**O. PROJECT BUDGET - OWNER COSTS**

**MUST USE WHOLE NUMBERS ONLY!**

Item	(A) Cost	Amount of Cost up to 100% Includable in Eligible Basis--Use Applicable Column(s):		
		"30% Present Value Credit"		(D)
		(B) Acquisition	(C) Rehab/ New Construction	"70 % Present Value Credit"
<b>2. Owner Costs</b>				
a. Building Permit	35,000	0	0	35,000
b. Architecture/Engineering Design Fee \$3,343 /Unit)	234,000	0	0	234,000
c. Architecture Supervision Fee \$714 /Unit)	50,000	0	0	50,000
d. Tap Fees	0	0	0	0
e. Environmental	25,000	0	0	25,000
f. Soil Borings	10,000	0	0	10,000
g. Green Building (Earthcraft, LEED, etc.)	25,000	0	0	25,000
h. Appraisal	8,000	0	0	8,000
i. Market Study	8,000	0	0	8,000
j. Site Engineering / Survey	20,000	0	0	20,000
k. Construction/Development Mgt	0	0	0	0
l. Structural/Mechanical Study	25,000	0	0	25,000
m. Construction Loan Origination Fee	0	0	0	0
n. Construction Interest ( 0.0% for 0 months)	0	0	0	0
o. Taxes During Construction	0	0	0	0
p. Insurance During Construction	40,000	0	0	40,000
q. Permanent Loan Fee ( 1.0% )	23,142	0	0	0
r. Other Permanent Loan Fees	0	0	0	0
s. Letter of Credit	0	0	0	0
t. Cost Certification Fee	30,000	0	0	30,000
u. Accounting	0	0	0	0
v. Title and Recording	30,000	0	0	19,500
w. Legal Fees for Closing	30,000	0	0	0
x. Mortgage Banker	0	0	0	0
y. Tax Credit Fee	57,781			
z. Tenant Relocation	20,000	0	0	0
aa. Fixtures, Furnitures and Equipment	0	0	0	0
ab. Organization Costs	0	0	0	0
ac. Operating Reserve	237,643	0	0	0
ad. Contingency	437,500	0	0	437,500
ae. Security	0	0	0	0
af. Utilities	0	0	0	0

**O. PROJECT BUDGET - OWNER COSTS**

(1) Other* specify: Rent Comp Study	6,500	0	0	6,500
(2) Other* specify:	0	0	0	
(3) Other* specify: Developer Legal	60,000	0	0	30,000
(4) Other* specify: Tax/Insurance Escrow	24,755	0	0	0
(5) Other* specify:	0	0	0	0
(6) Other* specify:	0	0	0	0
(7) Other* specify:	0	0	0	0
(8) Other* specify:	0	0	0	
(9) Other* specify:	0	0	0	0
(10) Other* specify:	0	0	0	0
Owner Costs Subtotal (Sum 2A..2(10))	\$1,437,321	\$0	\$0	\$1,003,500
<b>Subtotal 1 + 2</b> (Owner + Contractor Costs)	\$5,812,321	\$0	\$0	\$5,378,500
<b>3. Developer's Fees</b> Action: Provide Developer Fee Agreement (Tab A)	1,067,331	283,210	0	784,121
<b>4. Owner's Acquisition Costs</b>				
Land	175,000			
Existing Improvements	2,657,100	2,560,000		
Subtotal 4:	\$2,832,100	\$2,560,000		
<b>5. Total Development Costs</b>				
Subtotal 1+2+3+4:	\$9,711,752	\$2,843,210	\$0	\$6,162,621

If this application seeks rehab credits only, in which there is no acquisition and **no change in ownership**, enter the greater of appraised value or tax assessment value here:

(Provide documentation at Tab E)

\$0	Land
\$0	Building

**Maximum Developer Fee:** \$1,067,331

Proposed Development's Cost per Sq Foot \$102 **Meets Limits**  
 Applicable Cost Limit by Square Foot: \$126

2020 Low-Income Housing Tax Credit Application For Reservation

P. ELIGIBLE BASIS CALCULATION

Item	(A) Cost	Amount of Cost up to 100% Includable in Eligible Basis--Use Applicable Column(s):		
		(B) Acquisition	"30 % Present Value Credit"	(D) "70 % Present Value Credit"
			(C) Rehab/ New Construction	
<b>1. Total Development Costs</b>	9,711,752	2,843,210	0	6,162,621
<b>2. Reductions in Eligible Basis</b>				
a. Amount of federal grant(s) used to finance qualifying development costs		0	0	0
b. Amount of nonqualified, nonrecourse financing		0	0	0
c. Costs of nonqualifying units of higher quality (or excess portion thereof)		0	0	0
d. Historic Tax Credit (residential portion)		0	0	0
<b>3. Total Eligible Basis (1 - 2 above)</b>		2,843,210	0	6,162,621
<b>4. Adjustment(s) to Eligible Basis (For non-acquisition costs in eligible basis)</b>				
a. For QCT or DDA (Eligible Basis x 30%) <i>State Designated Basis Boosts:</i>			0	1,848,786
b. For Revitalization or Supportive Housing (Eligible Basis x 30%)			0	0
c. For Green Certification (Eligible Basis x 10%)				0
<b>Total Adjusted Eligible basis</b>			0	8,011,407
<b>5. Applicable Fraction</b>		100.00000%	100.00000%	100.00000%
<b>6. Total Qualified Basis (Eligible Basis x Applicable Fraction)</b>		2,843,210	0	8,011,407
<b>7. Applicable Percentage</b> <i>(Beginning with 2016 Allocations, use the standard 9% rate.)</i> <i>(For tax exempt bonds, use the most recently published rates.)</i>		3.17%	9.00%	9.00%
<b>8. Maximum Allowable Credit under IRC §42 (Qualified Basis x Applicable Percentage)</b> <i>(Must be same as BIN total and equal to or less than credit amount allowed)</i>		\$90,130	\$0	\$721,027
			\$811,157	
		Combined 30% & 70% P. V. Credit		

**Q. SOURCES OF FUNDS**

**Action:** Provide Documentation for all Funding Sources at **Tab T**

**1. Construction Financing:** List individually the sources of construction financing, including any such loans financed through grant sources:

Source of Funds	Date of Application	Date of Commitment	Amount of Funds	Name of Contact Person
1. ORIX Immediate Funding Perm Loan			\$2,314,242	Adam Diehl
2. Seller Note			\$97,100	Todd Travis
3. LIHTC Equity Available During Construction			\$6,676,264	Rich McCauley
Total Construction Funding:			\$9,087,606	

**2. Permanent Financing:** List individually the sources of all permanent financing in order of lien position:

Source of Funds	Date of Application	Date of Commitment	<i>(Whole Numbers only)</i>		Interest Rate of Loan	Amortization Period IN YEARS	Term of Loan (years)
			Amount of Funds	Annual Debt Service Cost			
1. ORIX Real Estate Capital, LLC			\$2,314,242	\$128,860	4.35%	35.00	18.00
2. Seller Note - Cash Flow Contingent			\$97,100				35.00
3.							
4.							
5.							
6.							
7.							
8.							
9.							
10.							
Total Permanent Funding:			\$2,411,342	\$128,860			

**3. Grants:** List all grants provided for the development:

Source of Funds	Date of Application	Date of Commitment	Amount of Funds	Name of Contact Person
1.				
2.				
3.				
4.				
5.				
6.				
Total Permanent Grants:			\$0	

**Q. SOURCES OF FUNDS**

**4. Subsidized Funding**

	Source of Funds	Date of Commitment	Amount of Funds
1.			
2.			
3.			
4.			
5.			
Total Subsidized Funding			\$0

**5. Recap of Federal, State, and Local Funds**

Portions of the sources of funds described above for the development are financed directly or indirectly with Federal, State, or Local Government Funds..... **FALSE**

If above is **True**, then list the amount of money involved by all appropriate types.

Below-Market Loans

a.	Tax Exempt Bonds	\$0
b.	RD 515	\$0
c.	Section 221(d)(3)	\$0
d.	Section 312	\$0
e.	Section 236	\$0
f.	VHDA SPARC/REACH	\$0
g.	HOME Funds	\$0
h.	Other:	\$0
i.	Other:	\$0

Market-Rate Loans

a.	Taxable Bonds	\$0
b.	Section 220	\$0
c.	Section 221(d)(3)	\$0
d.	Section 221(d)(4)	\$0
e.	Section 236	\$0
f.	Section 223(f)	\$0
g.	Other:	\$0

Grants\*

a.	CDBG	\$0
b.	UDAG	\$0

Grants

c.	State	
d.	Local	
e.	Other:	

\*This means grants to the partnership. If you received a loan financed by a locality which received one of the listed grants, please list it in the appropriate loan column as "other" and describe the applicable grant program which funded it.

**Q. SOURCES OF FUNDS**

---

**6. For Transactions Using Tax-Exempt Bonds Seeking 4% Credits:**

For purposes of the 50% Test, and based only on the data entered to this application, the portion of the aggregate basis of buildings and land financed with tax-exempt funds is: N/A

7. Some of the development's financing has credit enhancements..... FALSE  
If **True**, list which financing and describe the credit enhancement:

**8. Other Subsidies** **Action:** Provide documentation (**Tab Q**)

a. FALSE Real Estate Tax Abatement on the increase in the value of the development.

b. FALSE **New** project based subsidy from HUD or Rural Development for the greater of 5 or 10% of the units in the development.

c. FALSE Other

9. A HUD approval for transfer of physical asset is required..... FALSE

**2020 Low-Income Housing Tax Credit Application For Reservation**

**R. EQUITY**

**1. Equity**

a. Portion of Syndication Proceeds Attributable to Historic Tax Credit				
Amount of Federal historic credits	\$0	x Equity \$	\$0.000	= \$0
Amount of Virginia historic credits	\$0	x Equity \$	\$0.000	= \$0
b. Equity that Sponsor will Fund:				
i. Cash Investment	\$0			
ii. Contributed Land/Building	\$0			
iii. Deferred Developer Fee	\$0			(Note: Deferred Developer Fee cannot be negative.)
iv. Other:	\$0			
<b>ACTION:</b> If Deferred Developer Fee is greater than 50% of overall Developer Fee, provide a cash flow statement showing payoff within 15 years at <b>TAB A.</b>				
<b>Equity Total</b>	\$0			

**2. Equity Gap Calculation**

a. Total Development Cost	\$9,711,752
b. Total of Permanent Funding, Grants and Equity	- \$2,411,342
c. Equity Gap	\$7,300,410
d. Developer Equity	- \$726
e. Equity gap to be funded with low-income tax credit proceeds	\$7,299,684

**3. Syndication Information (If Applicable)**

a. Actual or Anticipated Name of Syndicator:	The Richman Group		
Contact Person:	Rich McCauley	Phone:	203-869-0900
Street Address:	777 West Putnam Ave		
City:	Greenwich	State:	6830
b. Syndication Equity			
i. Anticipated Annual Credits	\$811,157.00		
ii. Equity Dollars Per Credit (e.g., \$0.85 per dollar of credit)	\$0.900		
iii. Percent of ownership entity (e.g., 99% or 99.9%)	99.99000%		
iv. Syndication costs not included in Total Development Costs (e.g., advisory fees)	\$0		
v. Net credit amount anticipated by user of credits	\$811,076		
vi. Total to be paid by anticipated users of credit (e.g., limited partners)	\$7,299,684		
c. Syndication:	Private		
d. Investors:	Corporate		

**4. Net Syndication Amount**

Which will be used to pay for Total Development Costs \$7,299,684

**5. Net Equity Factor**

Must be equal to or greater than 85% 90.0000128385%



**2020 Low-Income Housing Tax Credit Application For Reservation**

**S. DETERMINATION OF RESERVATION AMOUNT NEEDED**

The following calculation of the amount of credits needed is substantially the same as the calculation which will be made by VHDA to determine, as required by the IRC, the amount of credits which may be allocated for the development. However, VHDA at all times retains the right to substitute such information and assumptions as are determined by VHDA to be reasonable for the information and assumptions provided herein as to costs (including development fees, profits, etc.), sources for funding, expected equity, etc. Accordingly, if the development is selected by VHDA for a reservation of credits, the amount of such reservation may differ significantly from the amount you compute below.

1. Total Development Costs		<u>\$9,711,752</u>
2. Less Total of Permanent Funding, Grants and Equity	-	<u>\$2,411,342</u>
3. Equals Equity Gap		<u>\$7,300,410</u>
4. Divided by Net Equity Factor (Percent of 10-year credit expected to be raised as equity investment)		<u>90.0000128385%</u>
5. Equals Ten-Year Credit Amount Needed to Fund Gap		<u>\$8,111,565</u>
Divided by ten years		<u>10</u>
6. Equals Annual Tax Credit Required to Fund the Equity Gap		<u>\$811,157</u>
7. Maximum Allowable Credit Amount (from Eligible Basis Calculation)		<u>\$811,157</u>
8. Requested Credit Amount	For 30% PV Credit:	<u>\$90,130</u>
	For 70% PV Credit:	<u>\$721,027</u>
Credit per LI Units	<u>\$11,587.9571</u>	
Credit per LI Bedroom	<u>\$4,886.4880</u>	
	<b>Combined 30% &amp; 70% PV Credit Requested</b>	<b>\$811,157</b>

9. **Action:** Provide Attorney’s Opinion (**Mandatory Tab H**)

**T. CASH FLOW**

**1. Revenue**

Indicate the estimated monthly income for the **Low-Income Units** (based on Unit Details tab):

Total Monthly Rental Income for LIHTC Units		\$44,012
Plus Other Income Source (list):	Laundry, Vending	\$322
Equals Total Monthly Income:		\$44,334
Twelve Months		x12
Equals Annual Gross Potential Income		\$532,008
Less Vacancy Allowance	5.0%	\$26,600
<b>Equals Annual Effective Gross Income (EGI) - Low Income Units</b>		<b>\$505,408</b>

**2. Indicate the estimated monthly income for the Market Rate Units** (based on Unit Details tab):

Total Monthly Income for Market Rate Units:		\$0
Plus Other Income Source (list):		\$0
Equals Total Monthly Income:		\$0
Twelve Months		x12
Equals Annual Gross Potential Income		\$0
Less Vacancy Allowance	0.0%	\$0
<b>Equals Annual Effective Gross Income (EGI) - Market Rate Units</b>		<b>\$0</b>

**Action:** Provide documentation in support of Operating Budget (**TAB R**)

**3. Cash Flow (First Year)**

a.	Annual EGI Low-Income Units	\$505,408
b.	Annual EGI Market Units	\$0
c.	Total Effective Gross Income	\$505,408
d.	Total Expenses	\$346,426
e.	Net Operating Income	\$158,982
f.	Total Annual Debt Service	\$128,860
g.	Cash Flow Available for Distribution	\$30,122

T. CASH FLOW

4. Projections for Financial Feasibility - 15 Year Projections of Cash Flow

	Stabilized Year 1	Year 2	Year 3	Year 4	Year 5
Eff. Gross Income	505,408	515,516	525,826	536,343	547,069
Less Oper. Expenses	346,426	356,819	367,523	378,549	389,906
Net Income	158,982	158,697	158,303	157,794	157,164
Less Debt Service	128,860	128,860	128,860	128,860	128,860
Cash Flow	30,122	29,837	29,443	28,934	28,304
Debt Coverage Ratio	1.23	1.23	1.23	1.22	1.22

	Year 6	Year 7	Year 8	Year 9	Year 10
Eff. Gross Income	558,011	569,171	580,554	592,166	604,009
Less Oper. Expenses	401,603	413,651	426,060	438,842	452,007
Net Income	156,408	155,520	154,494	153,323	152,002
Less Debt Service	128,860	128,860	128,860	128,860	128,860
Cash Flow	27,548	26,660	25,634	24,463	23,142
Debt Coverage Ratio	1.21	1.21	1.20	1.19	1.18

	Year 11	Year 12	Year 13	Year 14	Year 15
Eff. Gross Income	616,089	628,411	640,979	653,799	666,875
Less Oper. Expenses	465,568	479,535	493,921	508,738	524,000
Net Income	150,521	148,876	147,058	145,060	142,874
Less Debt Service	128,860	128,860	128,860	128,860	128,860
Cash Flow	21,661	20,016	18,198	16,200	14,014
Debt Coverage Ratio	1.17	1.16	1.14	1.13	1.11

Estimated Annual Percentage Increase in Revenue 2.00% (Must be < 2%)  
 Estimated Annual Percentage Increase in Expenses 3.00% (Must be > 3%)

**U. Building-by-Building Information**

**Must Complete**

Qualified basis must be determined on a building-by building basis. Complete the section below. Building street addresses are required by the IRS (must have them by the time of allocation request).

Number of BINS: 17

**FOR YOUR CONVENIENCE, COPY AND PASTE IS ALLOWED WITHIN BUILDING GRID**

Bldg #	BIN if known	NUMBER OF		Street Address 1 Street Address 2 City State Zip				30% Present Value Credit for Acquisition				30% Present Value Credit for Rehab / New Construction				70% Present Value Credit						
		TAX CREDIT UNITS	MARKET RATE UNITS					Estimate Qualified Basis	Actual or Anticipated In-Service Date	Applicable Percentage	Credit Amount	Estimate Qualified Basis	Actual or Anticipated In-Service Date	Applicable Percentage	Credit Amount	Estimate Qualified Basis	Actual or Anticipated In-Service Date	Applicable Percentage	Credit Amount			
				<b>DO NOT use the CUT feature</b>																		
1.		4	0	2150 Sinai Road		South Boston	VA	24592	\$162,469	01/01/21	3.17%	\$5,150					\$0	\$457,794	12/31/21	9.00%	\$41,201	
2.		4	0	2150 Sinai Road		South Boston	VA	24592	\$162,469	01/01/21	3.17%	\$5,150					\$0	\$457,795	12/31/21	9.00%	\$41,202	
3.		4	0	2150 Sinai Road		South Boston	VA	24592	\$162,469	01/01/21	3.17%	\$5,150					\$0	\$457,795	12/31/21	9.00%	\$41,202	
4.		4	0	2150 Sinai Road		South Boston	VA	24592	\$162,469	01/01/21	3.17%	\$5,150					\$0	\$457,795	12/31/21	9.00%	\$41,202	
5.		4	0	2150 Sinai Road		South Boston	VA	24592	\$162,469	01/01/21	3.17%	\$5,150					\$0	\$457,795	12/31/21	9.00%	\$41,202	
6.		4	0	2150 Sinai Road		South Boston	VA	24592	\$162,469	01/01/21	3.17%	\$5,150					\$0	\$457,795	12/31/21	9.00%	\$41,202	
7.		4	0	2150 Sinai Road		South Boston	VA	24592	\$162,469	01/01/21	3.17%	\$5,150					\$0	\$457,795	12/31/21	9.00%	\$41,202	
8.		4	0	2150 Sinai Road		South Boston	VA	24592	\$162,469	01/01/21	3.17%	\$5,150					\$0	\$457,795	12/31/21	9.00%	\$41,202	
9.		4	0	2150 Sinai Road		South Boston	VA	24592	\$162,469	01/01/21	3.17%	\$5,150					\$0	\$457,795	12/31/21	9.00%	\$41,202	
10.		4	0	2150 Sinai Road		South Boston	VA	24592	\$162,469	01/01/21	3.17%	\$5,150					\$0	\$457,795	12/31/21	9.00%	\$41,202	
11.		4	0	2150 Sinai Road		South Boston	VA	24592	\$162,469	01/01/21	3.17%	\$5,150					\$0	\$457,795	12/31/21	9.00%	\$41,202	
12.		4	0	2150 Sinai Road		South Boston	VA	24592	\$162,469	01/01/21	3.17%	\$5,150					\$0	\$457,795	12/31/21	9.00%	\$41,202	
13.		8	0	2150 Sinai Road		South Boston	VA	24592	\$324,939	01/01/21	3.17%	\$10,301					\$0	\$915,589	12/31/21	9.00%	\$82,403	
14.		4	0	2150 Sinai Road		South Boston	VA	24592	\$162,469	01/01/21	3.17%	\$5,150					\$0	\$457,794	12/31/21	9.00%	\$41,201	
15.		2	0	2150 Sinai Road		South Boston	VA	24592	\$81,235	01/01/21	3.17%	\$2,575					\$0	\$228,897	12/31/21	9.00%	\$20,601	
16.		4	0	2150 Sinai Road		South Boston	VA	24592	\$162,469	01/01/21	3.17%	\$5,150					\$0	\$457,794	12/31/21	9.00%	\$41,201	
17.		4	0	2150 Sinai Road		South Boston	VA	24592	\$162,470	01/01/21	3.17%	\$5,150					\$0	\$457,794	12/31/21	9.00%	\$41,201	
18.												\$0					\$0				\$0	
19.												\$0					\$0				\$0	
20.												\$0					\$0				\$0	
21.												\$0					\$0				\$0	
22.												\$0					\$0				\$0	
23.												\$0					\$0				\$0	
24.												\$0					\$0				\$0	
25.												\$0					\$0				\$0	
26.												\$0					\$0				\$0	
27.												\$0					\$0				\$0	
28.												\$0					\$0				\$0	
29.												\$0					\$0				\$0	
30.												\$0					\$0				\$0	
31.												\$0					\$0				\$0	
32.												\$0					\$0				\$0	
33.												\$0					\$0				\$0	
34.												\$0					\$0				\$0	
35.												\$0					\$0				\$0	
		70	0																			
Totals from all buildings								\$2,843,210					\$0					\$8,011,407				\$721,027

Number of BINS: 17

**V. STATEMENT OF OWNER**

---

The undersigned hereby acknowledges the following:

1. that, to the best of its knowledge and belief, all factual information provided herein or in connection herewith is true and correct, and all estimates are reasonable.
2. that it will at all times indemnify and hold harmless VHDA and its assigns against all losses, costs, damages, VHDA's expenses, and liabilities of any nature directly or indirectly resulting from, arising out of, or relating to VHDA's acceptance, consideration, approval, or disapproval of this reservation request and the issuance or nonissuance of an allocation of credits, grants and/or loan funds in connection herewith.
3. that points will be assigned only for representations made herein for which satisfactory documentation is submitted herewith and that no revised representations may be made in connection with this application once the deadline for applications has passed.
4. that this application form, provided by VHDA to applicants for tax credits, including all sections herein relative to basis, credit calculations, and determination of the amount of the credit necessary to make the development financially feasible, is provided only for the convenience of VHDA in reviewing reservation requests; that completion hereof in no way guarantees eligibility for the credits or ensures that the amount of credits applied for has been computed in accordance with IRC requirements; and that any notations herein describing IRC requirements are offered only as general guides and not as legal authority.
5. that the undersigned is responsible for ensuring that the proposed development will be comprised of qualified low-income buildings and that it will in all respects satisfy all applicable requirements of federal tax law and any other requirements imposed upon it by VHDA prior to allocation, should one be issued.
6. that the undersigned commits to providing first preference to members of targeted populations having state rental assistance and will not impose any eligibility requirements or lease terms terms for such individuals that are more restrictive than its standard requirements and terms, the terms of the MOU establishing the target population, or the eligibility requirements for the state rental assistance.
7. that, for the purposes of reviewing this application, VHDA is entitled to rely upon representations of the undersigned as to the inclusion of costs in eligible basis and as to all of the figures and calculations relative to the determination of qualified basis for the development as a whole and/or each building therein individually as well as the amounts and types of credit applicable thereof, but that the issuance of a reservation based on such representation in no way warrants their correctness or compliance with IRC requirements.
8. that VHDA may request or require changes in the information submitted herewith, may substitute its own figures which it deems reasonable for any or all figures provided herein by the undersigned and may reserve credits, if any, in an amount significantly different from the amount requested.
9. that reservations of credits are not transferable without prior written approval by VHDA at its sole discretion.

V. STATEMENT OF OWNER

- 10. that the requirements for applying for the credits and the terms of any reservation or allocation thereof are subject to change at any time by federal or state law, federal, state or VHDA regulations, or other binding authority.
- 11. that reservations may be made subject to certain conditions to be satisfied prior to allocation and shall in all cases be contingent upon the receipt of a nonrefundable application fee of \$1000 and a nonrefundable reservation fee equal to 7% of the annual credit amount reserved.
- 12. that a true, exact, and complete copy of this application, including all the supporting documentation enclosed herewith, has been provided to the tax attorney who has provided the required attorney's opinion accompanying this submission.
- 13. that the undersigned has provided a complete list of all residential real estate developments in which the general partner(s) has (have) or had a controlling ownership interest and, in the case of those projects allocated credits under Section 42 of the IRC, complete information on the status of compliance with Section 42 and an explanation of any noncompliance. The undersigned hereby authorizes the Housing Credit Agencies of states in which these projects are located to share compliance information with the Authority.
- 14. that any principal of undersigned has not participated in a planned foreclosure or Qualified Contract request in Virginia after January 1, 2019.
- 15. that undersigned waives the right to pursue a Qualified Contract on this development.
- 16. that the information in this application may be disseminated to others for purposes of verification or other purposes consistent with the Virginia Freedom of Information Act. However, all information will be maintained, used or disseminated in accordance with the Government Data Collection and Dissemination Practices Act. The undersigned may refuse to supply the information requested, however, such refusal will result in VHDA's inability to process the application. The original or copy of this application may be retained by VHDA, even if tax credits are not allocated to the undersigned.

In Witness Whereof, the undersigned, being authorized, has caused this document to be executed in its name on the date of this application set forth in DEV Info tab hereof.

Legal Name of Owner: Westside Village Renewal LLC

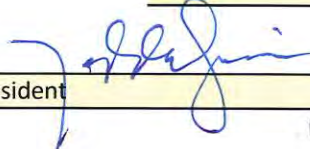
By:   
Its: President (Title)

V. STATEMENT OF ARCHITECT

---

The architect signing this document is certifying that the development plans and specifications incorporate all VHDA Minimum Design and Construction Requirements (MDCR), selected LIHTC enhancements and amenities, applicable building codes and accessibility requirements.

In Witness Whereof, the undersigned, being authorized, has caused this document to be executed in its name on the date of this application set forth in DEV Info tab hereof.

Legal Name of Architect: Charles R Hawley  
Virginia License#: 0401017672  
Architecture Firm or Company: Studio 343

By:   
Its: Principal  
(Title)

Initials by Architect are also required on the following Tabs: Enhancement, Special Housing Needs and Unit Details.

W.

**LIHTC SELF SCORE SHEET**

**Self Scoring Process**

This Self Scoring Process is intended to provide you with an estimate of your application's score based on the information included within the reservation application. Other items, denoted below in the yellow shaded cells, are typically evaluated by VHDA's staff during the application review and feasibility process. For purposes of self scoring, we have made certain assumptions about your application. Edit the appropriate responses (Y or N) in the yellow shaded cells, if applicable. Item 5f requires a numeric value to be entered.

Please remember that this score is only an estimate. VHDA reserves the right to change application data and/or score sheet responses where appropriate, which may change the final score.

**MANDATORY ITEMS:**

- a. Signed, completed application with attached tabs in PDF format
- b. Active Excel copy of application
- c. Partnership agreement
- d. SCC Certification
- e. Previous participation form
- f. Site control document
- g. RESNET Certification
- h. Attorney's opinion
- i. Nonprofit questionnaire (if applicable)
- j. Appraisal
- k. Zoning document
- l. Universal Design Plans
- m. List of LIHTC Developments (Schedule A)

Included		Score
Y	Y or N	0
Y	Y or N	0
Y	Y or N	0
Y	Y or N	0
Y	Y or N	0
Y	Y or N	0
Y	Y or N	0
Y	Y or N	0
Y	Y, N, N/A	0
Y	Y or N	0
Y	Y or N	0
Y	Y or N	0
Y	Y or N	0
Y	Y or N	0
Y	Y or N	0
Y	Y or N	0
Total:		0.00

**1. READINESS:**

- a. VHDA notification letter to CEO (via Locality Notification Information Application)
- b. Local CEO Opposition Letter
- c. Plan of development
- d. Location in a revitalization area based on Qualified Census Tract
- e. Location in a revitalization area with resolution
- f. Location in a Opportunity Zone

Y	0 or -50	0.00
N	0 or -25	0.00
N	0 or 40	0.00
N	0 or 10	0.00
Y	0 or 15	15.00
N	0 or 15	0.00
Total:		15.00

**2. HOUSING NEEDS CHARACTERISTICS:**

- a. Sec 8 or PHA waiting list preference
- b. Existing RD, HUD Section 8 or 236 program
- c. Subsidized funding commitments
- d. Tax abatement on increase of property's value
- e. New project based rental subsidy (HUD or RD)
- f. Census tract with <12% poverty rate
- g. Development listed on the Rural Development Rehab Priority List
- h. Dev. located in area with little or no increase in rent burdened population
- i. Dev. located in area with increasing rent burdened population

N	0 or up to 5	0.00
Y	0 or 20	20.00
0.00%	Up to 40	0.00
N	0 or 5	0.00
N	0 or 10	0.00
0%	0, 20, 25 or 30	0.00
N	0 or 15	0.00
N	Up to -20	0.00
N	Up to 20	0.00
Total:		20.00



**2020 Low-Income Housing Tax Credit Application For Reservation**

**3. DEVELOPMENT CHARACTERISTICS:**

a. Amenities (See calculations below)			68.00
b. Project subsidies/HUD 504 accessibility for 5 or 10% of units	Y	0 or 60	60.00
or c. HCV Payment Standard/HUD 504 accessibility for 5 or 10% of units	N	0 or 30	0.00
or d. HUD 504 accessibility for 5% of units	N	0 or 15	0.00
e. Proximity to public transportation (within Northern VA or Tidewater)	N	0, 10 or 20	0.00
f. Development will be Green Certified	Y	0 or 10	10.00
g. Units constructed to meet VHDA's Universal Design standards	10%	Up to 15	1.50
h. Developments with less than 100 units	Y	up to 20	12.00
i. Historic Structure	N	0 or 5	0.00
Total:			<u>151.50</u>

**4. TENANT POPULATION CHARACTERISTICS:**

Locality AMI	State AMI
\$55,800	\$57,400

a. Less than or equal to 20% of units having 1 or less bedrooms	Y	0 or 15	15.00
b. <plus> Percent of Low Income units with 3 or more bedrooms	40.00%	Up to 15	15.00
c. Units with rent at or below 30% of AMI and are not subsidized (up to 10% of LI units)	0.00%	Up to 10	0.00
d. Units with rents at or below 40% of AMI (up to 10% of LI units)	60.00%	Up to 10	10.00
e. Units with rent and income at or below 50% of AMI	40.00%	Up to 50	0.00
f. Units with rents at or below 50% rented to tenants at or below 60% of AMI	60.00%	Up to 25	0.00
or g. Units in LI Jurisdictions with rents <= 50% rented to tenants with <= 60% of AMI	60.00%	Up to 50	50.00
Total:			<u>90.00</u>

**5. SPONSOR CHARACTERISTICS:**

a. Developer experience - 3 developments with 3 x units or 6 developments with 1 x units	Y	0 or 50	50.00
or b. Developer experience - 3 developments and at least 500,000 in liquid assets	N	0 or 50	0.00
or c. Developer experience - 1 development with 1 x units	N	0 or 10	0.00
d. Developer experience - life threatening hazard	N	0 or -50	0.00
e. Developer experience - noncompliance	N	0 or -15	0.00
f. Developer experience - did not build as represented	0	0 or -2x	0.00
g. Developer experience - failure to provide minimum building requirements	N	0 or -20	0.00
h. Developer experience - termination of credits by VHDA	N	0 or -10	0.00
i. Developer experience - exceeds cost limits at certification	N	0 or -50	0.00
j. Management company rated unsatisfactory	N	0 or -25	0.00
Total:			<u>50.00</u>

**6. EFFICIENT USE OF RESOURCES:**

a. Credit per unit		Up to 200	39.73
b. Cost per unit		Up to 100	37.25
Total:			<u>76.98</u>

**7. BONUS POINTS:**

a. Extended compliance	0 Years	40 or 50	0.00
or b. Nonprofit or LHA purchase option	Y	0 or 60	60.00
or c. Nonprofit or LHA Home Ownership option	N	0 or 5	0.00
d. Combined 9% and 4% Tax Exempt Bond Site Plan	N	Up to 45	0.00
e. RAD or PHA Conversion participation and competing in Local Housing Authority pool	N	0 or 10	0.00
Total:			<u>60.00</u>

425 Point Threshold - all 9% Tax Credits  
 325 Point Threshold - Tax Exempt Bonds

**TOTAL SCORE:** 463.48

**2020 Low-Income Housing Tax Credit Application For Reservation**

---

**Amenities:**

All units have:	Max Pts	Score
a. Community Room	5	5.00
b. Exterior walls constructed with brick and other low maintenance materials	25	25.00
c. Sub metered water expense	5	5.00
d. Watersense labeled faucets, toilets and showerheads	3	0.00
e. Infrastructure for high speed internet/broadband	1	1.00
f. Free WiFi Access in community room	4	4.00
g. Each unit provided free individual high speed internet access	6	0.00
h. Each unit provided free individual WiFi	8	8.00
i. Bath Fan - Delayed timer or continuous exhaust	3	3.00
j. Baths equipped with humidistat	3	0.00
k. Cooking Surfaces equipped with fire prevention features	4	4.00
l. Cooking surfaces equipped with fire suppression features	2	0.00
m. Rehab only: dedicated space to accept permanent dehumidification system	2	0.00
n. Provides Permanently installed dehumidification system	5	5.00
o. All interior doors within units are solid core	3	3.00
p. USB in kitchen, living room and all bedrooms	1	1.00
q. LED Kitchen Light Fixtures	2	2.00
r. Shelf or Ledge at entrance within interior hallway	2	2.00
s. New Construction: Balcony or patio	4	0.00
		<u>68.00</u>
 All elderly units have:		
t. Front-control ranges	1	0.00
u. Independent/suppl. heat source	1	0.00
v. Two eye viewers	1	0.00
		<u>0.00</u>
<b>Total amenities:</b>		<u><b>68.00</b></u>

X. Development Summary

Summary Information

2020 Low-Income Housing Tax Credit Application For Reservation

**Deal Name:** Westside Village Apartments

**Cycle Type:** 9% Tax Credits  
**Allocation Type:** Acquisition/Rehab  
**Total Units:** 70  
**Total LI Units:** 70  
**Project Gross Sq Ft:** 67,160.00  
**Green Certified?:** TRUE

**Requested Credit Amount:** \$811,157  
**Jurisdiction:** Halifax County  
**Population Target:** General  
**Owner Contact:** Todd Travis

<b>Total Score</b> 463.48
------------------------------

Source of Funds	Amount	Per Unit	Per Sq Ft	Annual Debt Service
Permanent Financing	\$2,411,342	\$34,448	\$36	\$128,860

Uses of Funds - Actual Costs				
Type of Uses	Amount	Per Unit	Sq Ft	% of TDC
Improvements	\$3,837,730	\$54,825	\$57	39.52%
General Req/Overhead/Profit	\$537,270	\$7,675	\$8	5.53%
Other Contract Costs	\$0	\$0	\$0	0.00%
Owner Costs	\$1,437,321	\$20,533	\$21	14.80%
Acquisition	\$2,832,100	\$40,459	\$42	29.16%
Developer Fee	\$1,067,331	\$15,248	\$16	10.99%
<b>Total Uses</b>	<b>\$9,711,752</b>	<b>\$138,739</b>		

Total Development Costs	
Total Improvements	\$5,812,321
Land Acquisition	\$2,832,100
Developer Fee	\$1,067,331
<b>Total Development Costs</b>	<b>\$9,711,752</b>

Income		
Gross Potential Income - LI Units		\$532,008
Gross Potential Income - Mkt Units		\$0
Subtotal		\$532,008
Less Vacancy %	5.00%	\$26,600
<b>Effective Gross Income</b>		<b>\$505,408</b>

**Proposed Cost Limit/Sq Ft:** \$102  
**Applicable Cost Limit/Sq Ft:** \$126

Unit Breakdown	
Supp Hsg	0
# of Eff	0
# of 1BR	8
# of 2BR	34
# of 3BR	22
# of 4+ BR	6
<b>Total Units</b>	<b>70</b>

**Rental Assistance?** TRUE

Expenses		
Category	Total	Per Unit
Administrative	\$160,512	\$2,293
Utilities	\$59,234	\$846
Operating & Maintenance	\$56,171	\$802
Taxes & Insurance	\$49,509	\$707
<b>Total Operating Expenses</b>	<b>\$325,426</b>	<b>\$4,649</b>
Replacement Reserves	\$21,000	\$300
<b>Total Expenses</b>	<b>\$346,426</b>	<b>\$4,949</b>

	Income Levels	Rent Levels
	# of Units	# of Units
<=30% AMI	0	0
40% AMI	28	42
50% AMI	0	0
60% AMI	42	28
>60% AMI	0	0
Market	0	0

Cash Flow	
EGI	\$505,408
Total Expenses	\$346,426
<b>Net Income</b>	<b>\$158,982</b>
Debt Service	\$128,860
<b>Debt Coverage Ratio (YR1):</b>	<b>1.23</b>

**Income Averaging?** FALSE

**Extended Use Restriction?** 30

2020 Low-Income Housing Tax Credit Application For Reservation

\$/SF = **\$138.46** Credits/SF = **12.07798** Const \$/unit = **\$62,499.9943**

TYPE OF PROJECT GENERAL = 11000; ELDERLY = 12000  
 LOCATION Inner-NVA=100; Outer-NV=200; NWNC=300; Rich=400; Tid=500; Balance=600  
 TYPE OF CONSTRUCTION N C=1; ADPT=2; REHAB(35,000+)=3; REHAB (15,000-35,000)=4

**11000**  
**600**  
**3**

\*REHABS LOCATED IN BELTWAY (\$15,000-\$50,000) See Below

	GENERAL		Elderly				
	Supportive Hsg	EFF-E	1 BR-E	2 BR-E	EFF-E-1 ST	1 BR-E-1 ST	2 BR-E-1 ST
AVG UNIT SIZE	0.00	0.00	0.00	0.00	0.00	0.00	0.00
NUMBER OF UNITS	0	0	0	0	0	0	0
PARAMETER-(COSTS=>35,000)	0	0	0	0	0	0	0
PARAMETER-(COSTS<35,000)	0	0	0	0	0	0	0
PARAMETER-(COSTS=>50,000)	0	0	0	0	0	0	0
PARAMETER-(COSTS<50,000)	0	0	0	0	0	0	0
COST PARAMETER	0	0	0	0	0	0	0
PROJECT COST PER UNIT	0	0	0	0	0	0	0
PARAMETER-(CREDITS=>35,000)	0	0	0	0	0	0	0
PARAMETER-(CREDITS<35,000)	0	0	0	0	0	0	0
PARAMETER-(CREDITS=>50,000)	0	0	0	0	0	0	0
PARAMETER-(CREDITS<50,000)	0	0	0	0	0	0	0
CREDIT PARAMETER	0	0	0	0	0	0	0
PROJECT CREDIT PER UNIT	0	0	0	0	0	0	0
COST PER UNIT POINTS	0.00	0.00	0.00	0.00	0.00	0.00	0.00
CREDIT PER UNIT POINTS	0.00	0.00	0.00	0.00	0.00	0.00	0.00

	GENERAL							
	EFF-G	1 BR-G	2 BR-G	3 BR-G	4 BR-G	2 BR-TH	3 BR-TH	4 BR
AVG UNIT SIZE	0.00	623.00	859.00	1,137.27	1,325.00	0.00	0.00	0.00
NUMBER OF UNITS	0	8	34	22	6	0	0	0
PARAMETER-(COSTS=>35,000)	0	152,030	206,326	222,615	260,622	0	0	0
PARAMETER-(COSTS<35,000)	0	0	0	0	0	0	0	0
PARAMETER-(COSTS=>50,000)	0	152,030	206,326	222,615	260,622	0	0	0
PARAMETER-(COSTS<50,000)	0	0	0	0	0	0	0	0
COST PARAMETER	0	152,030	206,326	222,615	260,622	0	0	0
PROJECT COST PER UNIT	0	86,262	118,939	157,469	183,462	0	0	0
PARAMETER-(CREDITS=>35,000)	0	10,385	14,093	15,206	17,802	0	0	0
PARAMETER-(CREDITS<35,000)	0	0	0	0	0	0	0	0
PARAMETER-(CREDITS=>50,000)	0	10,385	14,093	15,206	17,802	0	0	0
PARAMETER-(CREDITS<50,000)	0	0	0	0	0	0	0	0
CREDIT PARAMETER	0	10,385	14,093	15,206	17,802	0	0	0
PROJECT CREDIT PER UNIT	0	7,525	10,375	13,736	16,003	0	0	0
COST PER UNIT POINTS	0.00	4.94	20.57	9.20	2.54	0.00	0.00	0.00
CREDIT PER UNIT POINTS	0.00	6.30	25.63	6.08	1.73	0.00	0.00	0.00

TOTAL COST PER UNIT POINTS **37.25**

TOTAL CREDIT PER UNIT POINTS **39.73**

**Cost Parameters - Elderly**

	Supportive Hsg	EFF-E	1 BR-E	2 BR-E	EFF-E-1 ST	1 BR-E-1 ST	2 BR-E-1 ST
Standard Cost Parameter - low rise	0	0	0	0	0	0	0
Parameter Adjustment - mid rise	0	0	0	0	0	0	0
Parameter Adjustment - high rise	0	0	0	0	0	0	0
<b>Adjusted Cost Parameter</b>	<b>0</b>	<b>0</b>	<b>0</b>	<b>0</b>	<b>0</b>	<b>0</b>	<b>0</b>

**Credit Parameters - Elderly**

	Supportive Hsg	EFF-E	1 BR-E	2 BR-E	EFF-E-1 ST	1 BR-E-1 ST	2 BR-E-1 ST
Standard Credit Parameter - low rise	0	0	0	0	0	0	0
Parameter Adjustment - mid rise	0	0	0	0	0	0	0
Parameter Adjustment - high rise	0	0	0	0	0	0	0
<b>Adjusted Credit Parameter</b>	<b>0</b>	<b>0</b>	<b>0</b>	<b>0</b>	<b>0</b>	<b>0</b>	<b>0</b>

**Cost Parameters - General**

	EFF-G	1 BR-G	2 BR-G	3 BR-G	4 BR-G	2 BR-TH	3 BR-TH	4 BR
Standard Parameter - low rise	0	152,030	206,326	222,615	260,622	0	0	0
Parameter Adjustment - mid rise	0	0	0	0	0	0	0	0
Parameter Adjustment - high rise	0	0	0	0	0	0	0	0
<b>Adjusted Cost Parameter</b>	<b>0</b>	<b>152,030</b>	<b>206,326</b>	<b>222,615</b>	<b>260,622</b>	<b>0</b>	<b>0</b>	<b>0</b>

**Credit Parameters - General**

	EFF-G	1 BR-G	2 BR-G	3 BR-G	4 BR-G	2 BR-TH	3 BR-TH	4 BR
Standard Credit Parameter - low rise	0	10,385	14,093	15,206	17,802	0	0	0
Parameter Adjustment - mid rise	0	0	0	0	0	0	0	0
Parameter Adjustment - high rise	0	0	0	0	0	0	0	0
<b>Adjusted Credit Parameter</b>	<b>0</b>	<b>10,385</b>	<b>14,093</b>	<b>15,206</b>	<b>17,802</b>	<b>0</b>	<b>0</b>	<b>0</b>

**Northern Virginia Beltway** (Rehab costs \$15,000-\$50,000)

**Cost Parameters - Elderly**

	Supportive Hsg	EFF-E	1 BR-E	2 BR-E	EFF-E-1 ST	1 BR-E-1 ST	2 BR-E-1 ST
Standard Cost Parameter - low rise	0	0	0	0	0	0	0
Parameter Adjustment - mid rise	0	0	0	0	0	0	0
Parameter Adjustment - high rise	0	0	0	0	0	0	0
<b>Adjusted Cost Parameter</b>	<b>0</b>	<b>0</b>	<b>0</b>	<b>0</b>	<b>0</b>	<b>0</b>	<b>0</b>

**Credit Parameters - Elderly**

	Supportive Hsg	EFF-E	1 BR-E	2 BR-E	EFF-E-1 ST	1 BR-E-1 ST	2 BR-E-1 ST
Standard Cost Parameter - low rise	0	0	0	0	0	0	0
Parameter Adjustment - mid rise	0	0	0	0	0	0	0
Parameter Adjustment - high rise	0	0	0	0	0	0	0
<b>Adjusted Cost Parameter</b>	<b>0</b>	<b>0</b>	<b>0</b>	<b>0</b>	<b>0</b>	<b>0</b>	<b>0</b>

**Cost Parameters - General**

	EFF-G	1 BR-G	2 BR-G	3 BR-G	4 BR-G	2 BR-TH	3 BR-TH	4 BR
Standard Cost Parameter - low rise	0	152,030	206,326	222,615	260,622	0	0	0
Parameter Adjustment - mid rise	0	0	0	0	0	0	0	0
Parameter Adjustment - high rise	0	0	0	0	0	0	0	0
<b>Adjusted Cost Parameter</b>	<b>0</b>	<b>152,030</b>	<b>206,326</b>	<b>222,615</b>	<b>260,622</b>	<b>0</b>	<b>0</b>	<b>0</b>

**Credit Parameters - General**

	EFF-G	1 BR-G	2 BR-G	3 BR-G	4 BR-G	2 BR-TH	3 BR-TH	4 BR
Standard Cost Parameter - low rise	0	10,385	14,093	15,206	17,802	0	0	0
Parameter Adjustment - mid rise	0	0	0	0	0	0	0	0
Parameter Adjustment - high rise	0	0	0	0	0	0	0	0
<b>Adjusted Cost Parameter</b>	<b>0</b>	<b>10,385</b>	<b>14,093</b>	<b>15,206</b>	<b>17,802</b>	<b>0</b>	<b>0</b>	<b>0</b>



t-TH  
)  
)  
)  
\_\_\_\_\_  
\_\_\_\_\_  
\_\_\_\_\_

t-TH  
)  
)  
)  
\_\_\_\_\_  
\_\_\_\_\_  
\_\_\_\_\_

t-TH  
)  
)  
)  
\_\_\_\_\_  
\_\_\_\_\_  
\_\_\_\_\_

t-TH  
)  
)  
)  
\_\_\_\_\_  
\_\_\_\_\_  
\_\_\_\_\_

2020 Low-Income Housing Tax Credit Application For Reservation

\$/SF = **\$138.46** Credits/SF = **12.07798** Const \$/unit = **\$62,499.99**

TYPE OF PROJECT: GENERAL = 11000; ELDERLY = 12000  
 LOCATION: Inner-NVA=100; Outer-NV=200; NWN=300; Rich=400; Tid=500; Balance=600  
 TYPE OF CONSTRUCTION: N C=1; ADPT=2; REHAB(35,000+)=3; REHAB\*(10,000-35,000)=4

**11000**  
**600**  
**3**

\*REHABS LOCATED IN BELTWAY (\$10,000-\$50,000) See Below

	GENERAL		Elderly				
	Supportive Hsg	EFF-E	1 BR-E	2 BR-E	EFF-E-1 ST	1 BR-E-1 ST	2 BR-E-1 ST
AVG UNIT SIZE	0.00	0.00	0.00	0.00	0.00	0.00	0.00
NUMBER OF UNITS	0	0	0	0	0	0	0
PARAMETER-(COSTS=>35,000)	0	0	0	0	0	0	0
PARAMETER-(COSTS<35,000)	0	0	0	0	0	0	0
PARAMETER-(COSTS=>50,000)	0	0	0	0	0	0	0
PARAMETER-(COSTS<50,000)	0	0	0	0	0	0	0
COST PARAMETER	0	0	0	0	0	0	0
PROJECT COST PER UNIT	0	0	0	0	0	0	0
PARAMETER-(CREDITS=>35,000)	0	0	0	0	0	0	0
PARAMETER-(CREDITS<35,000)	0	0	0	0	0	0	0
PARAMETER-(CREDITS=>50,000)	0	0	0	0	0	0	0
PARAMETER-(CREDITS<50,000)	0	0	0	0	0	0	0
CREDIT PARAMETER	0	0	0	0	0	0	0
PROJECT CREDIT PER UNIT	0	0	0	0	0	0	0
COST PER UNIT POINTS	0.00	0.00	0.00	0.00	0.00	0.00	0.00
CREDIT PER UNIT POINTS	0.00	0.00	0.00	0.00	0.00	0.00	0.00

	GENERAL							
	EFF-G	1 BR-G	2 BR-G	3 BR-G	4 BR-G	2 BR-TH	3 BR-TH	4 BR-TH
AVG UNIT SIZE	0.00	623.00	859.00	1,137.27	1,325.00	0.00	0.00	0.00
NUMBER OF UNITS	0	8	34	22	6	0	0	0
PARAMETER-(COSTS=>35,000)	0	152,030	206,326	222,615	260,622	0	0	0
PARAMETER-(COSTS<35,000)	0	0	0	0	0	0	0	0
PARAMETER-(COSTS=>50,000)	0	152,030	206,326	222,615	260,622	0	0	0
PARAMETER-(COSTS<50,000)	0	0	0	0	0	0	0	0
COST PARAMETER	0	152,030	206,326	222,615	260,622	0	0	0
PROJECT COST PER UNIT	0	86,262	118,939	157,469	183,462	0	0	0
PARAMETER-(CREDITS=>35,000)	0	10,385	14,093	15,206	17,802	0	0	0
PARAMETER-(CREDITS<35,000)	0	0	0	0	0	0	0	0
PARAMETER-(CREDITS=>50,000)	0	10,385	14,093	15,206	17,802	0	0	0
PARAMETER-(CREDITS<50,000)	0	0	0	0	0	0	0	0
CREDIT PARAMETER	0	10,385	14,093	15,206	17,802	0	0	0
PROJECT CREDIT PER UNIT	0	7,525	10,375	13,736	16,003	0	0	0
COST PER UNIT POINTS	0.00	4.94	20.57	9.20	2.54	0.00	0.00	0.00
CREDIT PER UNIT POINTS	0.00	6.30	25.63	6.08	1.73	0.00	0.00	0.00

TOTAL COST PER UNIT POINTS **37.25**

TOTAL CREDIT PER UNIT POINTS **39.73**



**Cost Parameters - Elderly**

	Supportive Hsg	EFF-E	1 BR-E	2 BR-E	EFF-E-1 ST	1 BR-E-1 ST	2 BR-E-1 ST
Standard Cost Parameter - low rise	0	0	0	0	0	0	0
Parameter Adjustment - mid rise	0	0	0	0	0	0	0
Parameter Adjustment - high rise	0	0	0	0	0	0	0
<b>Adjusted Cost Parameter</b>	<b>0</b>	<b>0</b>	<b>0</b>	<b>0</b>	<b>0</b>	<b>0</b>	<b>0</b>

**Credit Parameters - Elderly**

	Supportive Hsg	EFF-E	1 BR-E	2 BR-E	EFF-E-1 ST	1 BR-E-1 ST	2 BR-E-1 ST
Standard Credit Parameter - low rise	0	0	0	0	0	0	0
Parameter Adjustment - mid rise	0	0	0	0	0	0	0
Parameter Adjustment - high rise	0	0	0	0	0	0	0
<b>Adjusted Credit Parameter</b>	<b>0</b>	<b>0</b>	<b>0</b>	<b>0</b>	<b>0</b>	<b>0</b>	<b>0</b>

**Cost Parameters - General**

	EFF-G	1 BR-G	2 BR-G	3 BR-G	4 BR-G	2 BR-TH	3 BR-TH	4 BR-TH
Standard Parameter - low rise	0	152,030	206,326	222,615	260,622	0	0	0
Parameter Adjustment - mid rise	0	0	0	0	0	0	0	0
Parameter Adjustment - high rise	0	0	0	0	0	0	0	0
<b>Adjusted Cost Parameter</b>	<b>0</b>	<b>152,030</b>	<b>206,326</b>	<b>222,615</b>	<b>260,622</b>	<b>0</b>	<b>0</b>	<b>0</b>

**Credit Parameters - General**

	EFF-G	1 BR-G	2 BR-G	3 BR-G	4 BR-G	2 BR-TH	3 BR-TH	4 BR-TH
Standard Credit Parameter - low rise	0	10,385	14,093	15,206	17,802	0	0	0
Parameter Adjustment - mid rise	0	0	0	0	0	0	0	0
Parameter Adjustment - high rise	0	0	0	0	0	0	0	0
<b>Adjusted Credit Parameter</b>	<b>0</b>	<b>10,385</b>	<b>14,093</b>	<b>15,206</b>	<b>17,802</b>	<b>0</b>	<b>0</b>	<b>0</b>

**Northern Virginia Beltway** (Rehab costs \$10,000-\$50,000)

**Cost Parameters - Elderly**

	Supportive Hsg	EFF-E	1 BR-E	2 BR-E	EFF-E-1 ST	1 BR-E-1 ST	2 BR-E-1 ST
Standard Cost Parameter - low rise	0	0	0	0	0	0	0
Parameter Adjustment - mid rise	0	0	0	0	0	0	0
Parameter Adjustment - high rise	0	0	0	0	0	0	0
<b>Adjusted Cost Parameter</b>	<b>0</b>	<b>0</b>	<b>0</b>	<b>0</b>	<b>0</b>	<b>0</b>	<b>0</b>

**Credit Parameters - Elderly**

	Supportive Hsg	EFF-E	1 BR-E	2 BR-E	EFF-E-1 ST	1 BR-E-1 ST	2 BR-E-1 ST
Standard Cost Parameter - low rise	0	0	0	0	0	0	0
Parameter Adjustment - mid rise	0	0	0	0	0	0	0
Parameter Adjustment - high rise	0	0	0	0	0	0	0
<b>Adjusted Cost Parameter</b>	<b>0</b>	<b>0</b>	<b>0</b>	<b>0</b>	<b>0</b>	<b>0</b>	<b>0</b>

**Cost Parameters - General**

	EFF-G	1 BR-G	2 BR-G	3 BR-G	4 BR-G	2 BR-TH	3 BR-TH	4 BR-TH
Standard Cost Parameter - low rise	0	152,030	206,326	222,615	260,622	0	0	0
Parameter Adjustment - mid rise	0	0	0	0	0	0	0	0
Parameter Adjustment - high rise	0	0	0	0	0	0	0	0
<b>Adjusted Cost Parameter</b>	<b>0</b>	<b>152,030</b>	<b>206,326</b>	<b>222,615</b>	<b>260,622</b>	<b>0</b>	<b>0</b>	<b>0</b>

**Credit Parameters - General**

	EFF-G	1 BR-G	2 BR-G	3 BR-G	4 BR-G	2 BR-TH	3 BR-TH	4 BR-TH
Standard Cost Parameter - low rise	0	10,385	14,093	15,206	17,802	0	0	0
Parameter Adjustment - mid rise	0	0	0	0	0	0	0	0
Parameter Adjustment - high rise	0	0	0	0	0	0	0	0
<b>Adjusted Cost Parameter</b>	<b>0</b>	<b>10,385</b>	<b>14,093</b>	<b>15,206</b>	<b>17,802</b>	<b>0</b>	<b>0</b>	<b>0</b>



t-TH  
)  
)  
)  
)  
)  
)

t-TH  
)  
)  
)  
)  
)  
)

t-TH  
)  
)  
)  
)  
)  
)

t-TH  
)  
)  
)  
)  
)  
)

A

# Partnership or Operating Agreement

Including chart of ownership structure with percentage of  
interests (**MANDATORY**)

# WESTSIDE VILLAGE ORGANIZATIONAL CHART – CURRENT

**Westside Village Renewal LLC**  
a Virginia limited liability company  
EIN: 84-4466826  
Formed: 1/27/2020  
**OWNER**

**Westside Village Manager LLC**  
a Virginia limited liability company  
EIN: 84-4496559  
Formed: 1/27/2020  
100% Managing Member

**Huntington Housing, Inc.**  
a Maryland nonprofit corporation and  
501(C)3 organization  
EIN: 52-1879282  
Sole Member/Manager (100.00%)  
**Directors:**  
Jason Goldblatt, Gregory O’Dell, Benjamin M  
Soto  
  
**Officers:**  
Todd Travis – President  
Randall Kelly – Vice President  
John Parreco - Secretary



# WESTSIDE VILLAGE ORGANIZATIONAL CHART - PROPOSED

**Westside Village Renewal LLC**  
a Virginia limited liability company  
EIN: 84-4466826  
Formed: 1/27/2020  
**OWNER**

**Westside Village Manager LLC**  
a Virginia limited liability company  
EIN: 84-4496559  
Formed: 1/27/2020  
.01% Managing Member

**Huntington Housing, Inc.**  
a Maryland nonprofit corporation and  
501(C)3 organization  
EIN: 52-1879282  
Sole Member/Manager (100.00%)  
**Directors:**  
Jason Goldblatt, Gregory O'Dell, Benjamin M Soto  
**Officers:**  
Todd Travis – President  
Randall Kelly – Vice President  
John Parreco - Secretary

**Renewal Holdings LLC**  
A Delaware limited liability company  
EIN: 45-4701141  
99.99% Investor Member  
(Placeholder for LIHTC Equity Investor)

**Renewal Housing, Inc.**  
a Maryland nonprofit corporation and  
501(C)3 organization  
EIN: 52-1965128  
Sole Member/Manager (100.00%)  
**Directors:**  
Jason Goldblatt, Jon Shiffman, Benjamin M Soto  
**Officers:**  
Todd Travis – President  
Randall Kelly – VP  
Robert Custer - Secretary





**OPERATING AGREEMENT  
FOR  
WESTSIDE VILLAGE RENEWAL LLC**

**THIS OPERATING AGREEMENT** (as amended from time to time in accordance with the provisions hereof, the “**Agreement**”) is made and entered into as of the 27<sup>th</sup> day of January, 2020 by **WESTSIDE VILLAGE MANAGER LLC**, a Virginia limited liability company.

**ARTICLE I**

**Introduction**

**Section 1.1. Formation of Limited Liability Company.** The Member, desiring to form a Virginia limited liability company under the Virginia Limited Liability Company Act (as amended from time to time, the “**Act**”) have made this Agreement and has caused Articles of Organization to be executed and filed with the Commonwealth of Virginia State Corporation Commission (the “**Articles**”). The Articles are attached hereto as Exhibit B. The Company's business shall be conducted under the name “Westside Village Renewal LLC.”

This Agreement is subject to, and governed by, the Act and the Articles. In the event of a direct conflict between the provisions of this Agreement and either the Articles or the mandatory provisions of the Act, such provisions of the Articles or the Act, as the case may be, will be controlling.

**Section 1.2. Defined Terms.** The terms defined in the Preamble hereto and in Section 1.1 shall have the meanings specified therein, and all other capitalized terms used in this Agreement shall have the meanings set forth below.

1.2.1. “Accountants” means such accounting firm as may be retained from to time by the Member.

1.2.2. “Additional Member” means any individual or Entity admitted as a Member pursuant to Section 2.6 hereof.

1.2.3. “Affiliate” or “Affiliated Person” means any Person, directly or indirectly, through one or more intermediaries, controlling, controlled by, or under common control with, a Member. The term “control” as used in the immediately preceding sentence, means, with respect to a corporation, the right to exercise, directly or indirectly, more than 50% of the voting rights attributable to the controlled corporation, and, with respect to any Person, the possession, directly or indirectly, of the power to direct or cause the direction of the management or policies of the controlled Person.

1.2.4. “Authorized Person” means each of those persons who shall be authorized by the Member acting pursuant to Article III to execute or file documents on behalf of the Company and to otherwise act as its agent.

1.2.5. “Available Cash” of the Company means all cash funds of the Company on hand from time to time (other than cash funds obtained as contributions to the capital of the Company by the Members and cash funds obtained from loans to the Company) after (i) payment of all operating expenses of the Company as of such time, (ii) provision for payment of all outstanding and unpaid current obligations of the Company as of such time, and (iii) provision for a working capital reserve in accordance with Section 5.2 below.

1.2.6. “Capital Account” of the Member means the account established and maintained for the Member pursuant to Section 2.4. hereof.

1.2.7. “Capital Contribution” means the total value of cash and agreed fair market value of tangible and intangible property contributed and agreed to be contributed to the Company by the Member, as shown in Exhibit A, as the same may be amended from time to time. Any reference in this Agreement to the Capital Contribution of a then Member shall include a Capital Contribution previously made by any prior Member in respect of the interest of the then Member, reduced by any distribution to such Member in return of “Capital Contribution” as contemplated herein.

1.2.8. “Code” means the Internal Revenue Code of 1986, as amended. All references herein to sections of the Code shall include any corresponding provision or provisions of succeeding law.

1.2.9. “Company” means Westside Village Renewal LLC, the limited liability company to be formed under the Act upon the filing of the Articles and the subject of this Agreement.

1.2.10. “Entity” means any association, corporation, general partnership, limited partnership, limited liability company, limited liability partnership, joint stock association, joint venture, firm, trust, syndicate, business trust or cooperative, and any foreign associations of like structure.

1.2.11. “Interest” in the Company means the entire ownership interest of the Member in the Company at any particular time, including the right of the Member to any and all benefits to which the Member may be entitled as provided in this Agreement and under the Act, together with the obligations of the Member to comply with all of the terms and provisions of this Agreement.

1.2.12. “Manager” means Westside Village Manager LLC.

1.2.13. “Member” means Westside Village Manager LLC and any Additional Member.

1.2.14. “Person” means any individual or Entity.

1.2.15. “Principal Office” means the principal business office of the Company as established from time to time by the Member, initially being 11810 Grand Park Avenue, Suite 600, North Bethesda, Maryland 20852.

1.2.16. "Regulations" means the federal income tax regulations promulgated under the Code, as amended from time to time and including corresponding provisions of succeeding regulations.

1.2.17. "Resident Agent" means the resident agent as provided in the Articles attached hereto as Exhibit B, and any successor resident agent as provided in the Act.

1.2.18. "Term" shall refer to the term of this Company, beginning on the date the Articles are filed and being perpetual in duration, unless terminated pursuant to the Act or the terms of this Agreement.

**Section 1.3. Company Purpose.** The Company's business shall be to (a) to conduct any legal business, including, without limitation, the development, acquisition and ownership of real estate, participation with other entities involved in the same, and ownership and rehabilitation of the apartment project located in South Boston, Virginia known as Westside Village Apartments; (b) to have and exercise powers now or hereafter conferred by laws of the Commonwealth of Virginia on limited liability companies pursuant to the Act; and (c) to do any and all things necessary, convenient or incidental to achievement of the foregoing.

## ARTICLE II

### Member and Membership Interests

**Section 2.1. Name and Address of Member; Principal Office.** The Member, the Member's address, and their initial Capital Contributions to the Company are set forth on Exhibit A attached hereto and made a part hereof.

**Section 2.2. Form of Contributions.** The initial Capital Contributions were in the form and in the amounts or values provided in Exhibit A. Subsequent contributions shall be in such amounts and may be in any type of property as may be determined by the Member. The Member shall not be required to make any Capital Contribution to the Company other than the initial Capital Contribution except as may be provided under Section 2.4 hereof.

**Section 2.3. Member Loans or Services.** Loans by the Member to the Company shall not be considered contributions to the capital of the Company. Services may be considered contributions to capital if so determined by the Member.

### **Section 2.4. Capital and Capital Accounts.**

2.4.1. An individual Capital Account shall be established and maintained on behalf of each Member, including any additional or Substitute Member who shall hereafter receive an Interest in the Company. The Capital Account of each Member shall consist of (i) the amount of cash such Member has contributed to the Company plus (ii) the agreed fair market value of any tangible or intangible property such Member has contributed to the Company, net of any liabilities assumed by the Company or to which such property is subject, plus (iii) the amount of profits or income (including tax-exempt income and any other item required to be credited for proper maintenance of

capital accounts by the Regulations under Section 704(b) of the Code) allocated to such Member, less (iv) the amount of losses and deductions allocated to such Member, less (v) the amount of all cash distributed to such Member, less (vi) the fair market value of any property distributed to such Member, net of any liability assumed by such Member or to which such property is subject, and less (vii) such Member's share of any other expenditures which are not deductible by the Company for federal income tax purposes and which are not allowable as additions to the basis of Company property; all, however, subject to such other adjustments as may be required for proper maintenance of capital accounts by the Regulations under Section 704(b) of the Code. The Capital Account of a Member shall not be affected by any adjustments to basis made pursuant to Section 743 of the Code but shall be adjusted with respect to adjustments to basis made pursuant to Section 734 of the Code.

2.4.2. The opening entry for the Member shall be the Member' Capital Contribution as set forth on Exhibit A. No interest shall be paid on any Capital Contribution.

**Section 2.5. Contribution of Additional Capital.** Additional capital may be contributed to the Company.

**Section 2.6. Admission of Additional Member.** The Member may admit to the Company additional Member(s) who will participate in the profits, losses, available cash flow, and ownership of the assets of the Company on such terms as are determined by the Member. Such Additional Member shall be allocated gain, loss, income, or expense by such method as may be provided in this Agreement, or any amendment thereto.

**Section 2.7. Limitation of Liability.** The Member shall not be liable under a judgment, decree, or order of the court, or in any other manner, for a debt, obligation, or liability of the Company, except as otherwise required by law, it being the intent of the Member to have the fullest limitation of liability allowed by law. The Member shall not be required to loan any funds to the Company. Except as may be expressly provided otherwise herein, the Member shall not be required to make any contribution to the Company by reason of any negative balance in the Member' Capital Account, nor shall any negative balance in the Member' Capital Account create any liability on the part of the Member to any third party.

### ARTICLE III

#### Management and Control of Business

**Section 3.1. Overall Management Vested in Manager.** Management for the purpose of the business of the Company shall be vested in the Manager of the Company and all powers of the Company shall be exercised by or under the authority of, and the business and affairs of the Company shall be managed under the direction of, the Manager. The Member may appoint any natural person as Manager and may appoint such officers and hire such employees, and may invest such officers and employees with such duties, as the Member deems appropriate. The Member hereby appoints Westside Village Manager LLC as the initial Manager of the Company, to serve until its successor is duly appointed by the Member in accordance herewith.

**Section 3.2. Authorized Persons.** Any Authorized Person duly authorized by the Member may execute any document or instrument authorized to be executed on behalf of the Company without the necessity of joinder by the Member, Manager or any other person. Any duly Authorized Person and any officer or employee designated by the Manager shall have authority to sign checks.

**Section 3.3. Conduct of Business.** In the conduct of its business activities, the Company shall:

- (i) maintain books and records separate from those of any other person or entity, including the Member;
- (ii) refrain from commingling its assets with those of any other entity, including the Member;
- (iii) conduct its own business in its own name;
- (iv) maintain financial statements separate and apart from any other entity, including the Member;
- (v) pay its own liabilities out of its own funds;
- (vi) observe all limited liability company formalities including without limitation holding all meetings and obtaining all consents required by this Agreement;
- (vii) maintain an arm's-length relationship with its affiliates;
- (viii) pay the salaries of its own employees;
- (ix) not guarantee or become obligated for the debts of any other entity or hold out its credit as being available to satisfy the obligations of others, including the Member;
- (x) allocate fairly and reasonably any overhead for shared office space or other similar expenses;
- (xi) use separate invoices, checks and stationary; and
- (xii) hold itself out as and operate as a separate entity.

## **ARTICLE IV**

### **Accounting and Records**

#### **Section 4.1. Records and Accounting.**

4.1.1. The books and records of the Company shall be kept, and the financial position and the results of its operations recorded using the accrual method and otherwise in accordance with

the accounting methods elected to be followed by the Company for federal income tax purposes. The books and records of the Company shall reflect all Company transactions and shall be appropriate and adequate for the Company's business.

4.1.2. The Member may engage an employee of the Company to be responsible for: authenticating the records of the Company, including keeping correct and complete books of account which show accurately at all times the financial condition of the Company, safeguarding all funds, notes, securities, and other valuables which may from time to time come into possession of the Company, depositing all funds of the Company with such depositories as the Member shall designate. Such employee shall have such other duties as the Member may from time to time prescribe, but under no circumstances shall such employee have any of the rights, powers, responsibilities, or duties of the Member of the Company as prescribed herein or by law.

**Section 4.2. Accounting Decisions.** All decisions as to accounting matters, except as otherwise specifically set forth herein, shall be made by the Manager. The Manager may rely upon the advice of the Accountants as to whether such decisions are in accordance with applicable accounting methods for federal income tax or general accounting purposes.

**Section 4.3. Federal Income Tax Elections.** The Company may make all elections for federal income tax purposes, including but not limited to, the following:

(a) to the extent permitted by applicable law and regulations, the election to use an accelerated depreciation method on any depreciable unit of the assets of the Company;

(b) in case of a transfer of all or part of a Member's Interest or the distribution to the Member of Company property, the election pursuant to Sections 734, 743 and 754 of the Code to adjust the basis of the assets of the Company; and

(c) the election to “check the box” to be treated as a partnership for federal income tax purposes.

## ARTICLE V

### Allocations; Distributions; Interests

**Section 5.1. Allocation of Net Income, Net Loss or Capital Gains.** In accordance with the Code and Resolutions, all net income or net loss and/or capital gains of the Company for each fiscal year of the Company shall be allocated to the Member.

**Section 5.2. Distribution of Available Cash.** Upon the decision of the Member, the Available Cash of the Company, if any, shall be distributed to the Member, or in such other manner as the Member may decide. Available Cash of the Company shall not be distributed if such cash is required to maintain a reasonable working capital reserve for the Company.

**Section 5.3. Allocation of Income and Loss and Distributions in respect of Interests Transferred.**

5.3.1. If any Interest in the Company is transferred, or is increased or decreased by reason of the admission of a new Member or otherwise, during any fiscal year of the Company, each item of income, gain, loss, deduction, or credit of the Company for such fiscal year shall be assigned pro rata to each day in the particular period of such fiscal year to which such item is attributable (i.e., the day on or during which it is accrued or otherwise incurred) and the amount of each such item so assigned to any such day shall be allocated to the Member based upon his or her respective Interest in the Company at the close of such day. For the purpose of accounting convenience and simplicity, the Company may treat a transfer of, or an increase or decrease in, an Interest in the Company which occurs at any time during a monthly period (commencing with the monthly period including the date hereof) as having been consummated on the first day of the calendar month following such monthly period, regardless of when during such monthly period such transfer, increase or decrease actually occurs (i.e., sales and dispositions made during any month will be deemed to have been made on the first (1st) day of the next calendar month).

5.3.2. Distributions of Company assets in respect of an Interest in the Company shall be made only to the Member who, according to the books and records of the Company, are the holders of record of the Interests in respect of which such distributions are made on the actual date of distribution. Neither the Company nor the Member shall incur any liability for making distributions in accordance with the provisions of the preceding sentence, whether or not the Company or the Member has knowledge or notice of any transfer or purported transfer of ownership of Interest in the Company. Notwithstanding any provision above to the contrary, gain or loss of the Company realized in connection with a sale or other disposition of any of the assets of the Company shall be allocated solely to the parties owning Interests in the Company as of the date such sale or other disposition occurs.

## ARTICLE VI

### Changes in Member

#### **Section 6.1. Dissolution.**

6.1.1. There shall be no events of dissolution except as required by applicable law, or by Section 7.1.1.

6.1.2. Upon the occurrence of a mandatory event of dissolution under applicable law, the Company shall dissolve and its affairs shall be wound up and its properties liquidated, in accordance with Section 7.1.2.

**Section 6.2. Transfer and Assignment of Member's Interest; Admission of Additional Member.** The Member shall be entitled to assign, convey, sell, pledge, hypothecate, encumber or in any way alienate (hereinafter, collectively a "Transfer") all or any part of its Interest in the Company. No transferee or Additional Member shall become a Member, however, unless or until such transferee agrees in writing to be bound by this Agreement as the same may be amended to accommodate such admission.

**Section 6.3. Effect of Transfer.** Any permitted transfer of all or any portion of the Member's Interest in the Company will take effect on the first day of the month following such transfer.

## **ARTICLE VII**

### **Termination**

#### **Section 7.1. Termination of the Company.**

7.1.1. The Company shall be dissolved, its assets shall be disposed of, and its affairs wound up on the first to occur of the following:

- (i) a determination by the Member that the Company should be so dissolved;
- (ii) the occurrence of a mandatory event of dissolution under applicable law;
- (iii) the termination of both Member' existence; or
- (iv) at such earlier time as may be required by applicable law.

7.1.2. In settling accounts of the Company after dissolution, the liabilities of the Company shall be entitled to payment in the following order, all as required by the Act:

- (i) liabilities to creditors, in the order of priority as provided by law, except liabilities to the Member of the Company on account of their contributions;
- (ii) liabilities to the Member of the Company in respect of their share of the profits and other compensation by way of income on its contributions; and
- (iii) liabilities to the Member of the Company in respect of their contributions to capital.

## **ARTICLE VIII**

### **Indemnification**

#### **Section 8.1. Liability and Indemnification of the Member and Authorized Persons.**

8.1.1. No Authorized Person shall be liable, responsible or accountable, in damages or otherwise, to the Member for any act performed by it within the scope of the authority conferred on it by this Agreement, except for acts of fraud, willful misconduct or gross negligence.

8.1.2. The Member and each Authorized Person shall be entitled to indemnity from the Company for any act performed by it in good faith and within the scope of the authority conferred on it by or pursuant to this Agreement, except for acts of fraud, willful misconduct or gross negligence.



and for damages arising from any material misrepresentation herein or material breach of warranty herein.

8.1.3. Any indemnity under this Section 8.1. shall be provided out of and to the extent of Company assets only, and the Member shall not have any personal liability on account thereof beyond their Capital Contribution.

8.1.4. The Company may purchase and maintain insurance for its benefit, the benefit of the Member or any Authorized Person who is entitled to indemnification under this Section or both, against any liability asserted against or incurred by the Member or Authorized Person in any capacity or arising out of the Member' or such Authorized Person's service with the Company, whether or not the Company would have the power to indemnify such individual against such liability.

## ARTICLE IX

### Miscellaneous

**Section 9.1. Effect of Agreement.** This Agreement is intended to be the Operating Agreement of the Company within the meaning of the Act.

**Section 9.2. Governing Law.** This Agreement and the rights of the parties hereunder will be governed by, interpreted and enforced in accordance with, the laws of the Commonwealth of Virginia.

**Section 9.3. Binding Effect.** Subject to the provisions of this Agreement relating to transferability, this Agreement will be binding upon and inure to the benefit of the Member and its respective distributees, heirs, successors and assigns.

**Section 9.4. Terms.** Common nouns and pronouns will be deemed to refer to the masculine, feminine, neuter, singular, and plural, as the identity of the Person may in the context require.

**Section 9.5. Headings.** All headings herein are inserted only for convenience and ease of reference and in no way define, limit or describe the scope of this Agreement or the intent of the provisions thereof and are not to be considered in the construction or interpretation of any provision of this Agreement.

**Section 9.6. Severability.** If any provision of this Agreement is held to be illegal, invalid, or unenforceable under the present or future laws effective during the term of this Agreement, such provision will be fully severable; this Agreement will be construed and enforced as if such illegal, invalid, or unenforceable provision had never comprised a part of this Agreement, but with due regard to the intent of the Member, and the remaining provisions of this Agreement will remain in full force and effect and will not be affected by the illegal, invalid, or unenforceable provision or by its severance from this Agreement.

**Section 9.7. No Third Party Beneficiary.** This Agreement is made solely and specifically by and for the benefit of the party hereto, and its respective successors and assigns subject to the

express provisions hereof relating to successors and assigns, and no other Person will have any rights, interest, or claims hereunder or be entitled to any benefits under or on account of this Agreement as a third party beneficiary or otherwise.

**Section 9.8. Amendments.** This Agreement may not be amended except by written amendment signed by the Member.

**Section 9.9. Title to Company Property.** Legal title to all property of the Company will be held and conveyed in the name of the Company.

**Section 9.10. VHDA-Required Language.** Notwithstanding any other provision of this Agreement, this limited liability company and the members shall be subject to regulation and supervision by the Authority in accordance with the Virginia Housing Development Authority Act, the Rules and Regulations of the Authority, and the Regulatory Agreement assumed or to be assumed by this limited liability company and shall be further subject to the exercise by the Authority of the rights and powers conferred on the Authority thereby. Notwithstanding any other provision of this Agreement, the Authority may rely upon the continuing effect of this provision which shall not be amended, altered, waived, supplemented or otherwise changed without the prior written consent of the Authority.

**Section 9.11. Purchase Option and Right of First Refusal.** After the close of the mandatory fifteen (15) year compliance period for the low-income housing tax credit for the Project (the “**Compliance Period**”) as determined under Section 42(i)(1) of the Internal Revenue Code of 1986, as amended (the “**Code**”), Huntington Housing, Inc. shall have the right of first refusal to acquire the Project for a price not to exceed the outstanding debt and exit taxes, as further set forth in that certain Purchase Option attached hereto as Exhibit C to be recorded in the appropriate recorder’s office of Wythe County, Virginia.

*Remainder of page intentionally left blank. Signature page follows.*

IN WITNESS WHEREOF, the Member have executed this Agreement on the date set forth opposite its signature, effective as of the date first written above.

**MEMBER:**

**WESTSIDE VILLAGE MANAGER LLC,**  
a Virginia limited liability company

By: Huntington Housing, Inc.,  
a Maryland nonstock corporation

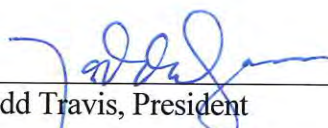
By:   
\_\_\_\_\_  
Todd Travis, President

**OPERATING AGREEMENT**  
**FOR**  
**WESTSIDE VILLAGE RENEWAL LLC**

---

**EXHIBIT A**

<u>Member</u>	<u>Address</u>	<u>Percentage Interest</u>	<u>Capital Contribution</u>
Westside Village Manager LLC	11810 Grand Park Ave Suite 600 North Bethesda, MD 20852	100%	\$100.00



## DEVELOPMENT AGREEMENT

**THIS DEVELOPMENT AGREEMENT** (this “Agreement”) is made and entered into effective as of the \_\_\_ day of September 2020 by and between Huntington Housing, Inc. a Maryland nonprofit corporation and 501(C)3 organization (the “Developer”), and Westside Village Renewal LLC, a Virginia limited liability company (the “Company”).

### WITNESSETH:

WHEREAS, the Company has been formed for the purposes, *inter alia*, of acquiring, financing, owning, constructing, developing, maintaining, improving, operating, leasing and selling or otherwise disposing of certain real property together with all improvements, furnishings, equipment and personal property to be located thereon (together, the land and improvements are known as Westside Village Apartments and will be collectively referred to as the “Project”), which Project is intended to be rented and managed in order that it will qualify for the low-income housing tax credit provided in Section 42 of the Internal Revenue Code of 1986, as amended (the “Code”);

WHEREAS, in order to effectuate the purposes for which it has been formed, the Company has engaged the services of the Developer with respect to overseeing the development of the Project for the Company; and

WHEREAS, the parties desire to enter into this Agreement that amends and restates in total any and all prior agreements and sets forth the obligations of, and the services to be performed by, the Developer and the compensation for such services.

NOW, THEREFORE, in consideration of the mutual promises and covenants contained herein and for other good and valuable consideration, the receipt and sufficiency of which is hereby acknowledged, the parties hereto, intending to be legally bound, hereby agree as follows:

**Section 1. Obligations of the Developer.** The Developer shall have the following duties, to the extent they have not already been performed:

(a) to assist, advise and consult on the selection of and provide coordination and supervision of the architect and engineer in connection with the preparation of and any changes to the site plan for the Project and the renderings, drawings and specifications for construction of Improvements (the “Plans and Specifications”);

(b) to be cognizant of and advise the Company with respect to any and all rules or regulations, city ordinances, including health and fire safety regulations, or any other requirements of law or governmental authorities applicable to the development and construction of the Improvements and to coordinate the services of professionals in connection therewith;

(c) to assist, coordinate and supervise the obtaining of all necessary building permits and approvals for and in connection with the development and construction of the Project;

(d) to consult, advise and assist in preparing a development and construction budget and pro forma cash flow projections and coordinating professionals in connection therewith;

(e) to cooperate and coordinate with the construction contractors appointed by the Company;

(f) to otherwise use commercially reasonable best efforts to coordinate, supervise and cause the development and construction of the Project on a timely basis and within the contemplated budget;

(g) to record the progress on all of the foregoing, and, as requested, submit written progress reports to the Company; and

(h) to maintain or cause to be maintained at its sole cost and expense all off-site office and accounting facilities and equipment necessary to adequately perform all functions of Developer specified herein.

The Developer may retain the services of independent consultants, provided the Company shall have no responsibility to such independent parties.

**Section 2. Development Fee.** In consideration of the performance by the Developer of the development services described herein, the Company shall pay to the Developer a development fee (the "Development Fee") in the amount set forth on Exhibit A attached hereto. The Company and the Developer acknowledge that specific portions of the Development Fee shall be earned by Developer as certain benchmarks are satisfied as more particularly described on Exhibit A, but in any event, all of the Development Fee shall be earned upon Stabilization and Receipt of 8609's. All amounts due and payable hereunder shall be paid in accordance with Section \_\_\_\_\_ of the Amended and Restated Operating Agreement of the Company dated as of \_\_\_\_\_, 2020. Developer shall not be compensated for, and no portion of the Development Fee shall apply to, services in connection with the development of nonresidential improvements, the organization or syndication of the Company, obtaining an allocation of Credits or securing Project financing other than construction financing, it being the understanding between the parties hereto that all such listed activities and services are the exclusive responsibility of the Company, the Managing Member and/or consultants or others engaged by the Company.

**Section 3. Termination of Duties and Responsibilities of Developer.** The Developer shall have no further duties or obligations hereunder after Stabilization and Receipt of 8609's including completion of all punch list items. The Developer's duties, responsibilities and rights hereunder shall not be terminated by the Company except for "cause" as finally determined by a court of competent jurisdiction. For purposes hereof, "cause" shall mean fraud, dishonesty,

reckless disregard for customary practices and intentional misconduct after at least 30 days' prior notice and opportunity to cure.

#### **Section 4. Miscellaneous.**

(a) This Agreement shall be binding upon the parties hereto and their respective successors and permitted assigns. This Agreement may not be assigned by any of the parties hereto without the written consent of the other party, except that the Developer may assign its rights but not its duties under this Agreement.

(b) The descriptive paragraph headings of this Agreement are inserted for convenience only and are not intended to and shall not be construed to limit, enlarge, or affect the scope or intent of this Agreement nor the meaning of any provision hereof.

(c) This Agreement and the rights and obligations of the parties hereto shall be governed and construed and enforced in accordance with the laws of the Commonwealth of Virginia.

(d) This Agreement embodies the entire agreement and understanding between the parties relating to the subject matter hereof and supersedes all prior agreements and understandings related to such subject matter, and it is agreed that there are no terms, understandings, representations or warranties, express or implied, other than those set forth herein.

(e) This Agreement shall not be amended or modified in any respect without the prior written consent of each party hereto.

(f) No party hereto shall file or attempt to file this Agreement of record.

(g) This Agreement and the obligations of the Developer hereunder are solely for the benefit of the Company and its Members and no benefits to third parties are intended.

(h) In the event any provision hereof is deemed to be unenforceable or against public policy, then such provision shall be deemed omitted from this Agreement and to the extent possible such provision shall be replaced with an enforceable provision which corresponds with the spirit of the omitted provision, and no other provision of this Agreement shall be affected by such omission or unenforceability.

(i) The parties agree that the prevailing party in any action or dispute involving litigation concerning the subject matter hereof, shall be entitled to attorneys' fees and court costs.

(j) The waiver by any party of any breach of this Agreement shall not operate or be construed to be a waiver of any subsequent breach.



(k) All capitalized terms herein shall have the same meanings as set forth in the Company Agreement, except as otherwise expressly set forth herein.

**Section 5. Notice.** Any notice required to be given hereunder shall be in writing and mailed by certified mail, postage prepaid, or hand delivered with receipt of service simultaneously to all parties at the addresses set forth in the Operating Agreement. Each party shall have the right to change its address for the receipt of notices, upon the giving of proper notice to all other parties hereto. Whenever a period of time is to be computed from the date of receipt of an item of certified mail, such period shall be computed from the fifth day following the date of mailing if delivery of the certified mail item is refused by the party to whom it was directed.

**Section 6. Counterparts.** This Agreement may be executed in several counterparts, each of which shall be deemed to be an original copy and all of which together shall constitute one agreement binding on all parties hereto, notwithstanding that all the parties shall not have signed the same counterpart.

**Section 7. Responsibilities of the Company.** In order for the Developer to perform duties described herein, the Company shall:

- (a) provide full information regarding its requirements for the Project;
- (b) designate a representative who shall be fully acquainted with the scope of the work and has authority to render decisions promptly and furnish information expeditiously; and
- (c) if the Company becomes aware of any fault or defect in the Project or nonconformance with any contract or other documents, it shall give prompt written notice thereof to the Developer.

**Section 8. Independent Contractor.** The parties hereto do not intend to create a Company or any similar association for any purpose. The Developer shall be an independent contractor for all purposes.

IN WITNESS WHEREOF, the parties have executed this Development Agreement on the date and year first above written.

DEVELOPER:

By: Huntington Housing, Inc., a Maryland nonprofit corporation and 501(C)3 organization

By: \_\_\_\_\_  
Todd Travis  
President

COMPANY:

WESTSIDE VILLAGE RENEWAL LLC, a Virginia limited liability company

By: Westside Village Manager LLC, a Virginia limited liability company

By: Huntington Housing, Inc. its sole member

By: \_\_\_\_\_  
Todd Travis  
President

**EXHIBIT A**  
**FEE SCHEDULE**

Total Development Fee            \$1,067,331

Earned in accordance with the following schedule:

Closing	33.33%
Achieving 100% Completion	33.33%
Stabilization and 8609's	<u>33.33%</u>
	100%

- (i) \$355,777 upon receipt by the Company of the First Installment;
- (ii) \$355,777 upon receipt by the Company of the Second Installment;
- (iii) \$355,777 upon receipt by the Company of the Third Installment;
- (iv) any amounts not paid from an Installment, projected to be \$0 shall (1) accrue interest at the rate of 3.50% per annum, compounded annually, and (2) be payable from Net Cash Flow as provided in Section \_\_\_\_\_ of the Operating Agreement and/or from proceeds available for such purpose upon the occurrence of any of the events described in Section \_\_\_\_ of the Operating Agreement.

B

Virginia State Corporation  
Commission Certification  
(MANDATORY)

# Commonwealth of Virginia



## STATE CORPORATION COMMISSION

Richmond, January 27, 2020

This is to certify that the certificate of organization of

### **Westside Village Renewal LLC**

was this day issued and admitted to record in this office and that the said limited liability company is authorized to transact its business subject to all Virginia laws applicable to the company and its business.

Effective date: January 27, 2020



STATE CORPORATION COMMISSION

Attest:

*Joel H. Heck*

\_\_\_\_\_  
Clerk of the Commission

C

Principal's Previous  
Participation Certification  
(MANDATORY)



## Previous Participation Certification

Development Name: Westside Village Apartments  
Name of Applicant (entity): Westside Village Renewal LLC

I hereby certify that:

1. All the statements made by me are true, complete and correct to the best of my knowledge and belief and are made in good faith, including the data contained in Schedule A and any statements attached to this certification.
2. During any time that any of the participants were principals in any multifamily rental property, no property has been foreclosed upon, in default or assigned to the mortgage insurer (governmental or private); nor has mortgage relief by the mortgagee been given;
3. During any time that any of the participants were principals in any multifamily rental property, there has not been any breach by the owner of any agreements relating to the construction or rehabilitation, use, operation, management or disposition of the property, including removal from a partnership;
4. That at no time have any principals listed in this certification been required to turn in a property to the investor or have been removed from a multifamily rental property ownership structure;
5. That to the best of my knowledge, there are no unresolved findings raised as a result of state or federal audits, management reviews or other governmental investigations concerning any multifamily rental property in which any of the participants were principals;
6. During any time that any of the participants were principals in any multifamily rental property, there has not been a suspension or termination of payments under any state or federal assistance contract for the property;
7. None of the participants has been convicted of a felony and is not presently, to my knowledge, the subject of a complaint or indictment charging a felony. A felony is defined as any offense punishable by imprisonment for a term exceeding one year, but does not include any offense classified as a misdemeanor under the laws of a state and punishable by imprisonment of two years or less;
8. None of the participants has been suspended, debarred or otherwise restricted by any federal or state governmental entity from doing business with such governmental entity; and

**Previous Participation Certification, cont'd**

9. None of the participants has defaulted on an obligation covered by a surety or performance bond and has not been the subject of a claim under an employee fidelity bond.
10. None of the participants is a Virginia Housing Development Authority (VHDA) employee or a member of the immediate household of any of its employees.
11. None of the participants is participating in the ownership of a multifamily rental housing property as of this date on which construction has stopped for a period in excess of 20 days or, in the case of a multifamily rental housing property assisted by any federal or state governmental entity, which has been substantially completed for more than 90 days but for which requisite documents for closing, such as the final cost certification, have not been filed with such governmental entity.
12. None of the participants has been found by any federal or state governmental entity or court to be in noncompliance with any applicable civil rights, equal employment opportunity or fair housing laws or regulations.
13. None of the participants was a principal in any multifamily rental property which has been found by any federal or state governmental entity or court to have failed to comply with Section 42 of the Internal Revenue Code of 1986, as amended, during the period of time in which the participant was a principal in such property. This does not refer to corrected 8823's.
14. None of the participants is currently named as a defendant in a civil lawsuit arising out of their ownership or other participation in a multi-family housing development where the amount of damages sought by plaintiffs (i.e., the ad damnum clause) exceeds One Million Dollars (\$1,000,000).
15. None of the participants has pursued a Qualified Contract or planned foreclosure in Virginia after January 1, 2019.

Statements above (if any) to which I cannot certify have been deleted by striking through the words. In the case of any such deletion, I have attached a true and accurate statement to explain the relevant facts and circumstances.

Failure to disclose information about properties which have been found to be out of compliance or any material misrepresentations are grounds for rejection of an application and prohibition against future applications.

Signature

  
**Todd Travis**

Printed Name

3/6/2020

Date (no more than 30 days prior to submission of the Application)



D

# List of LIHTC Developments

(Schedule A)  
(MANDATORY)

# List of LIHTC Developments (Schedule A)



Development Name: Westside Village Apartments  
 Name of Applicant: Westside Village Renewal LLC

**INSTRUCTIONS:**

- 1 **A Schedule A is required for every individual that makes up the GP or Managing Member** - does not apply to principals of publicly traded corporations.
- 2 For each property for which an **uncorrected** 8823 has been issued, provide a detailed explanation of the nature of the non-compliance, as well as a status statement.
- 3 List only tax credit development experience since 2004 (i.e. for the past 15 years)
- 4 Use separate pages as needed, for each principal.

Westside Village Manager LLC Controlling GP (CGP) or 'Named' Managing Member of Proposed property? Y - HHI Sole Member  
 Principal's Name: Y or N

	Development Name/Location	Name of Ownership Entity and Phone Number	CGP or 'Named' Managing Member at the time of dev.? (Y/N)*	Total Dev. Units	Total Low Income Units	Placed in Service Date	8609(s) Issue Date	Uncorrected 8823's? (Y/N) Explain "Y"
1	[Newly Formed]	N/A	N/A	N/A	N/A	N/A	N/A	N/A
2								
3								
4								
5								
6								
7								
8								
9								
10								
11								
12								
13								
14								
15								
16								
17								
18								
19								
20								
21								
22								
23								
24								
25								
26								
27								
28								
29								
30								
31								
32								
33								
34								
35								
36								
37								
38								
39								
40								

\* Must have the ability to bind the LIHTC entity; document with partnership/operating agreements and one 8609 (per entity/development) for a total of 6.

1st PAGE TOTAL: 0 0 #DIV/0! LIHTC as % of Total Units

ADD ADDITIONAL PROPERTIES USING NEXT TAB

# List of LIHTC Developments (Schedule A)



Development Name: Westside Village Apartments  
 Name of Applicant: Westside Village Renewal LLC

**INSTRUCTIONS:**

- 1 A Schedule A is required for every individual that makes up the GP or Managing Member - does not apply to principals of publicly traded corporations.
- 2 For each property for which an uncorrected 8823 has been issued, provide a detailed explanation of the nature of the non-compliance, as well as a status statement.
- 3 List only tax credit development experience since 2004 (i.e. for the past 15 years)
- 4 Use separate pages as needed, for each principal.

Principal's Name: Huntington Housing, Inc. Controlling GP (CGP) or 'Named' Managing Member of Proposed property? Y  
Y or N

Development #	Development Name/Location	Name of Ownership Entity and Phone Number	CGP or 'Named' Managing Member at the time of dev.? (Y/N)*	Total Dev. Units	Total Low Income Units	Placed in Service Date	8609(s) Issue Date	Uncorrected 8823's? (Y/N) Explain "Y"
1	Springdale Village / Bristol, VA	Springdale Affordable LLC	N	136	136	12/1/2012	6/20/2013	N
2	Settlers Point / Damascus, VA	Settlers Point Affordable LLC	N	62	62	12/13/2012	4/12/2013	N
3	Northwinds Apartments / Wytheville, VA	Northwinds Renewal LLC	N	144	142	12/31/2015	7/18/2016	N
4	Burton Creek Apartments / Lynchburg, VA	Burton Creek Renewal LLC	N	85	85	12/31/2019	Not issued yet	N
5								
6								
7								
8								
9								
10								
11								
12								
13								
14								
15								
16								
17								
18								
19								
20								
21								
22								
23								
24								
25								
26								
27								
28								
29								
30								
31								
32								
33								
34								
35								
36								
37								
38								
39								
40								

\* Must have the ability to bind the LIHTC entity; document with partnership/operating agreements and one 8609 (per entity/development) for a total of 6.

1st PAGE TOTAL:      427      425      LIHTC as % of Total Units      100%

ADD ADDITIONAL PROPERTIES USING NEXT TAB

List of LIHTC Developments (Schedule A)



Development Name: Westside Village Apartments  
 Name of Applicant: Westside Village Renewal LLC

**INSTRUCTIONS:**

- 1 A Schedule A is required for every individual that makes up the GP or Managing Member - does not apply to principals of publicly traded corporations.
- 2 For each property for which an uncorrected 8823 has been issued, provide a detailed explanation of the nature of the non-compliance, as well as a status statement.
- 3 List only tax credit development experience since 2004 (i.e. for the past 15 years)
- 4 Use separate pages as needed, for each principal.

Principal's Name: <u>Todd Travis</u>		Controlling GP (CGP) or 'Named' Managing Member of Proposed property? <u>N</u>							
Development Name/Location	Name of Ownership Entity and Phone Number	CGP or 'Named' Managing Member at the time of dev.? (Y/N)*	Total Dev. Units	Total Low Income Units	Placed in Service Date	8609(s) Issue Date	Uncorrected 8823's? (Y/N) Explain "Y"		
1	Union Gardens/ Montclair, NJ	Union Affordable LP 301-998-0402	N	87	76	12/31/2011	9/27/2012	N	
2	King Towers/ Washington DC	King Housing LLC 301-998-0402	N	129	114	12/31/2011	5/31/2015	N	
3	Glenarden Woods / Glenarden, MD	Glenarden Affordable LLC 301-998-0402	N	153	153	8/31/2012	12/13/2013	N	
4	Glenreed Apartments / Lanham, MD	Glenreed Affordable LLC 301-998-0402	N	104	104	8/31/2012	12/9/2013	N	
5	Springdale Village / Bristol, VA	Springdale Affordable LLC 301-998-0402	N	136	136	12/1/2012	6/20/2013	N	
6	Settlers Point / Damascus, VA	Settlers Point Affordable LLC 301-998-0602	N	62	62	12/13/2013	4/12/2013	N	
7	Mid-Pine Estates / Princess Anne, MD	Mid Pine Family LP 301-998-0402	N	36	36	9/26/2012	1/13/2014	N	
8	Asbury Park Gardens / Asbury Park, NJ	APNJ Partners, LP 301-998-0402	N	170	159	10/1/2013	11/14/2014	N	
9	Salem Lafayette / Jersey City, NJ	Salem Lafayette Urban Renewal LP 301-998-0402	N	411	411	5/1/2014	9/3/2015	Y	
10	Lewis Park Apartments / St. Paul, MN	Lewis Park Renewal LLC 301-998-0402	N	103	103	12/31/2014	9/28/2015	N	
11	Eastport Townhomes / Mankato, MN	Eastport Renewal LLC 301-998-0402	N	78	78	12/31/2014	10/7/2015	N	
12	Seward Square Apartments / Minneapolis, MN	Seward Renewal LLC 301-998-0402	N	81	81	12/31/2014	9/23/2015	N	
13	McConnell Hills / Tuscaloosa, AL	McConnell Hills Preservation LLC 301-998-0402	N	100	100	12/31/2014	11/19/2015	N	
14	Gus Johnson Apartments / Mankato, MN	Gus Johnson Renewal LLC 301-998-0402	N	107	107	12/31/2015	6/17/2016	N	
15	Northwinds Apartments / Wytheville, VA	Northwinds Renewal LLC 301-998-0402	N	144	142	12/31/2015	7/18/2016	N	
16	Maple Knoll Townhomes / Maplewood, MN	Maple Knoll Renewal LLC 301-998-0402	N	57	57	12/31/2015	8/2/2016	N	
17	Shadley Apartments / Belvidere, IL	Shadley Renewal LLC 301-998-0402	N	118	118	12/31/2015	8/11/2016	N	
18	Quincy Point Apartments / Quincy, PA	1000 Southern Artery Renewal LLC 301-998-0402	N	640	640	8/1/2015	12/22/2017	N	
19	Mount Carmel Apartments / Mount Carmel, PA	Mount Carmel Renewal LLC 301-998-0402	N	100	100	12/31/2015	TBD	N	
20	Kish Apartments / Lewistown, PA	Kish Renewal LLC 301-998-0402	N	140	140	12/31/2015	TBD	N	
21	Chemung Apartments / Athens, PA	Chemung View Renewal LLC 301-998-0402	N	100	100	12/31/2015	TBD	N	
22	Watts Arms I Apartments / Los Angeles, CA	Watts Arms I Renewal LP 301-998-0402	N	104	103	2/3/2017	TBD	N	
23	Maple House Apartments / Ossining, NY	Maple Housing Renewal LLC 301-998-0402	N	105	105	9/29/2017	11/30/2018	N	
24	Wah Luck House / Washington, DC	Wah Luck House Preservation LLC 301-998-0402	N	152	152	12/21/2017	TBD	N	
25	Madison Apartments / Minneapolis, MN	Madison Renewal LLC 301-998-0402	N	51	51	12/20/2019	TBD	N	
26	Four Freedoms / Miami Beach, FL	Four Freedoms Renewal LLLP 301-998-0402	N	216	216	12/20/2019	TBD	N	
27	Morningside Apartments / Chicago, IL	Morningside Renewal LLC 301-998-0402	N	256	256	3/15/2019	TBD	N	
28	Cedar River Tower / Waterloo, IA	Cedar River Renewal LLC 301-998-0402	N	85	85	2/13/2020	TBD	N	
29	Ontario Townhomes / Ontario, CA	Ontario TH Renewal LP	N	87	87	3/20/2019	TBD	N	
30	Oakwood Apartments / Bellingham, MA	Oakwood Renewal LLC	N	91	91	12/31/2019	TBD	N	
31	Burton Creek Apartments / Lynchburg, VA	Burton Creek Renewal LLC	N	85	85	12/31/2019	Not issued yet	N	
32									
33									
34									
35									
36									
37									
38									
39									
40									

\* Must have the ability to bind the LIHTC entity; document with partnership/operating agreements and gns 8602 (per entity/development) for a total of 6.

1st PAGE TOTAL: 4,288 4,248

LIHTC as % of Total Units 99%

## **Explanation of Noncompliance**

On March 29, 2017 New Jersey Housing and Mortgage Finance Agency (“NJHMFA”) issued six (6) uncorrected noncompliance 8823’s for Salem Lafayette Apartments in Jersey City, NJ. The uncorrected 8823’s were due to tenants whose income exceeded the maximum allowable amount for the LIHTC program at the time of acquisition. The NJHMFA inspector found noncompliance in six (6) units out of 411. The explanation for the non-compliance is that the tenants resided at the property prior to acquisition and the income requirements at that time were different than the current LIHTC requirements. The tenant’s household income qualified under HUD guidelines and could not be relocated. No credits were claimed on these units; however, NJHMFA’s position is that they still represent instances of non-compliance because the property was initially subject to 100% of the units being LIHTC restricted under the initial LURA. NJHMFA has indicated that the open 8823’s will remain uncorrected until those residents move out and new tenants move in that meet the LIHTC income limits.

List of LIHTC Developments (Schedule A)



Development Name: Westside Village Apartments  
 Name of Applicant: Westside Village Renewal LLC

**INSTRUCTIONS:**

- A Schedule A is required for every individual that makes up the GP or Managing Member - does not apply to principals of publicly traded corporations.
- For each property for which an uncorrected 8823 has been issued, provide a detailed explanation of the nature of the non-compliance, as well as a status statement.
- List only tax credit development experience since 2004 (i.e. for the past 15 years)
- Use separate pages as needed, for each principal.

Principal's Name: <u>Randall Kelly</u>		Controlling GP (CGP) or 'Named' Managing Member of Proposed property? <u>N</u>							
Development Name/Location	Name of Ownership Entity and Phone Number	CGP or 'Named' Managing Member at the time of dev.? (Y/N)*	Total Dev. Units	Total Low Income Units	Placed in Service Date	8609(s) Issue Date	Uncorrected 8823's? (Y/N) Explain "Y"		
1	Union Gardens/ Montclair, NJ	Union Affordable LP 301-998-0402	N	87	76	12/31/2011	9/27/2012	N	
2	King Towers/ Washington DC	King Housing LLC 301-998-0402	N	129	114	12/31/2011	5/31/2015	N	
3	Glenarden Woods / Glenarden, MD	Glenarden Affordable LLC 301-998-0402	N	153	153	8/31/2012	12/13/2013	N	
4	Glenreed Apartments / Lanham, MD	Glenreed Affordable LLC 301-998-0402	N	104	104	8/31/2012	12/9/2013	N	
5	Springdale Village / Bristol, VA	Springdale Affordable LLC 301-998-0402	N	136	136	12/1/2012	6/20/2013	N	
6	Settlers Point / Damascus, VA	Settlers Point Affordable LLC 301-998-0602	N	62	62	12/13/2013	4/12/2013	N	
7	Mid-Pine Estates / Princess Anne, MD	Mid Pine Family LP 301-998-0402	N	36	36	9/26/2012	1/13/2014	N	
8	Asbury Park Gardens / Asbury Park, NJ	APNJ Partners, LP 301-998-0402	N	170	159	10/1/2013	11/14/2014	N	
9	Salem Lafayette / Jersey City, NJ	Salem Lafayette Urban Renewal LP 301-998-0402	N	411	411	5/1/2014	9/3/2015	Y	
10	Lewis Park Apartments / St. Paul, MN	Lewis Park Renewal LLC 301-998-0402	N	103	103	12/31/2014	9/28/2015	N	
11	Eastport Townhomes / Mankato, MN	Eastport Renewal LLC 301-998-0402	N	78	78	12/31/2014	10/7/2015	N	
12	Seward Square Apartments / Minneapolis, MN	Seward Renewal LLC 301-998-0402	N	81	81	12/31/2014	9/23/2015	N	
13	McConnell Hills / Tuscaloosa, AL	McConnell Hills Preservation LLC 301-998-0402	N	100	100	12/31/2014	11/19/2015	N	
14	Gus Johnson Apartments / Mankato, MN	Gus Johnson Renewal LLC 301-998-0402	N	107	107	12/31/2015	6/17/2016	N	
15	Northwinds Apartments / Wytheville, VA	Northwinds Renewal LLC 301-998-0402	N	144	142	12/31/2015	7/18/2016	N	
16	Maple Knoll Townhomes / Maplewood, MN	Maple Knoll Renewal LLC 301-998-0402	N	57	57	12/31/2015	8/2/2016	N	
17	Shadley Apartments / Belvidere, IL	Shadley Renewal LLC 301-998-0402	N	118	118	12/31/2015	8/11/2016	N	
18	Quincy Point Apartments / Quincy, PA	1000 Southern Artery Renewal LLC 301-998-0402	N	640	640	8/1/2015	12/22/2017	N	
19	Mount Carmel Apartments / Mount Carmel, PA	Mount Carmel Renewal LLC 301-998-0402	N	100	100	12/31/2015	TBD	N	
20	Kish Apartments / Lewistown, PA	Kish Renewal LLC 301-998-0402	N	140	140	12/31/2015	TBD	N	
21	Chemung Apartments / Athens, PA	Chemung View Renewal LLC 301-998-0402	N	100	100	12/31/2015	TBD	N	
22	Watts Arms I Apartments / Los Angeles, CA	Watts Arms I Renewal LP 301-998-0402	N	104	103	2/3/2017	TBD	N	
23	Maple House Apartments / Ossining, NY	Maple Housing Renewal LLC 301-998-0402	N	105	105	9/29/2017	11/30/2018	N	
24	Wah Luck House / Washington, DC	Wah Luck House Preservation LLC 301-998-0402	N	152	152	12/21/2017	TBD	N	
25	Madison Apartments / Minneapolis, MN	Madison Renewal LLC 301-998-0402	N	51	51	12/20/2019	TBD	N	
26	Four Freedoms / Miami Beach, FL	Four Freedoms Renewal LLLP 301-998-0402	N	216	216	12/20/2019	TBD	N	
27	Morningside Apartments / Chicago, IL	Morningside Renewal LLC 301-998-0402	N	256	256	3/15/2019	TBD	N	
28	Cedar River Tower / Waterloo, IA	Cedar River Renewal LLC 301-998-0402	N	85	85	2/13/2020	TBD	N	
29	Ontario Townhomes / Ontario, CA	Ontario TH Renewal LP	N	87	87	3/20/2019	TBD	N	
30	Oakwood Apartments / Bellingham, MA	Oakwood Renewal LLC	N	91	91	12/31/2019	TBD	N	
31	Burton Creek Apartments / Lynchburg, VA	Burton Creek Renewal LLC	N	85	85	12/31/2019	Not issued yet	N	
32									
33									
34									
35									
36									
37									
38									
39									
40									

\* Must have the ability to bind the LIHTC entity; document with partnership/operating agreements and gms 8602 (per entity/development) for a total of 6.

1st PAGE TOTAL: 4,288 4,248

LIHTC as % of Total Units 99%

## **Explanation of Noncompliance**

On March 29, 2017 New Jersey Housing and Mortgage Finance Agency (“NJHMFA”) issued six (6) uncorrected noncompliance 8823’s for Salem Lafayette Apartments in Jersey City, NJ. The uncorrected 8823’s were due to tenants whose income exceeded the maximum allowable amount for the LIHTC program at the time of acquisition. The NJHMFA inspector found noncompliance in six (6) units out of 411. The explanation for the non-compliance is that the tenants resided at the property prior to acquisition and the income requirements at that time were different than the current LIHTC requirements. The tenant’s household income qualified under HUD guidelines and could not be relocated. No credits were claimed on these units; however, NJHMFA’s position is that they still represent instances of non-compliance because the property was initially subject to 100% of the units being LIHTC restricted under the initial LURA. NJHMFA has indicated that the open 8823’s will remain uncorrected until those residents move out and new tenants move in that meet the LIHTC income limits.

# List of LIHTC Developments (Schedule A)



Development Name: Westside Village Apartments  
 Name of Applicant: Westside Village Renewal LLC

**INSTRUCTIONS:**

- 1 **A Schedule A is required for every individual that makes up the GP or Managing Member** - does not apply to principals of publicly traded corporations.
- 2 For each property for which an uncorrected 8823 has been issued, provide a detailed explanation of the nature of the non-compliance, as well as a status statement.
- 3 List only tax credit development experience since 2004 (i.e. for the past 15 years)
- 4 Use separate pages as needed, for each principal.

Principal's Name: Jason Goldblatt Controlling GP (CGP) or 'Named' Managing Member of Proposed property? N  
Y or N

Development Name/Location	Name of Ownership Entity and Phone Number	CGP or 'Named' Managing Member at the time of dev.? (Y/N)*	Total Dev. Units	Total Low Income Units	Placed in Service Date	8609(s) Issue Date	Uncorrected 8823's? (Y/N) Explain "Y"
1	No Experience	Not Involved in Day to Day Operations	N/A	N/A	N/A	N/A	N/A
2							
3							
4							
5							
6							
7							
8							
9							
10							
11							
12							
13							
14							
15							
16							
17							
18							
19							
20							
21							
22							
23							
24							
25							
26							
27							
28							
29							
30							
31							
32							
33							
34							
35							
36							
37							
38							
39							
40							

\* Must have the ability to bind the LIHTC entity; document with partnership/operating agreements and one 8609 (per entity/development) for a total of 6.

1st PAGE  
 TOTAL:           0           0           #DIV/0!  
 LIHTC as % of  
 Total Units

ADD ADDITIONAL PROPERTIES USING NEXT TAB



# List of LIHTC Developments (Schedule A)



Development Name: Westside Village Apartments  
 Name of Applicant: Westside Village Renewal LLC

**INSTRUCTIONS:**

- 1 A Schedule A is required for every individual that makes up the GP or Managing Member - does not apply to principals of publicly traded corporations.
- 2 For each property for which an uncorrected 8823 has been issued, provide a detailed explanation of the nature of the non-compliance, as well as a status statement.
- 3 List only tax credit development experience since 2004 (i.e. for the past 15 years)
- 4 Use separate pages as needed, for each principal.

Principal's Name: Gregory O'Dell Controlling GP (CGP) or 'Named' Managing Member of Proposed property? N  
 Y or N

	Development Name/Location	Name of Ownership Entity and Phone Number	CGP or 'Named' Managing Member at the time of dev.? (Y/N)*	Total Dev. Units	Total Low Income Units	Placed in Service Date	8609(s) Issue Date	Uncorrected 8823's? (Y/N) Explain "Y"
1	No Experience	Not Involved in Day to Day Operations	N/A	N/A	N/A	N/A	N/A	N/A
2								
3								
4								
5								
6								
7								
8								
9								
10								
11								
12								
13								
14								
15								
16								
17								
18								
19								
20								
21								
22								
23								
24								
25								
26								
27								
28								
29								
30								
31								
32								
33								
34								
35								
36								
37								
38								
39								
40								

\* Must have the ability to bind the LIHTC entity; document with partnership/operating agreements and one 8609 (per entity/development) for a total of 6.

1st PAGE TOTAL: 0 0 #DIV/0! LIHTC as % of Total Units

ADD ADDITIONAL PROPERTIES USING NEXT TAB

# List of LIHTC Developments (Schedule A)



Development Name: Westside Village Apartments  
 Name of Applicant: Westside Village Renewal LLC

**INSTRUCTIONS:**

- 1 **A Schedule A is required for every individual that makes up the GP or Managing Member** - does not apply to principals of publicly traded corporations.
- 2 For each property for which an uncorrected 8823 has been issued, provide a detailed explanation of the nature of the non-compliance, as well as a status statement.
- 3 List only tax credit development experience since 2004 (i.e. for the past 15 years)
- 4 Use separate pages as needed, for each principal.

Principal's Name: Benjamin M Soto Controlling GP (CGP) or 'Named' Managing Member of Proposed property? N  
 Y or N

Development Name/Location	Name of Ownership Entity and Phone Number	CGP or 'Named' Managing Member at the time of dev.? (Y/N)*	Total Dev. Units	Total Low Income Units	Placed in Service Date	8609(s) Issue Date	Uncorrected 8823's? (Y/N) Explain "Y"
1	No Experience	Not Involved in Day to Day Operations	N/A	N/A	N/A	N/A	N/A
2							
3							
4							
5							
6							
7							
8							
9							
10							
11							
12							
13							
14							
15							
16							
17							
18							
19							
20							
21							
22							
23							
24							
25							
26							
27							
28							
29							
30							
31							
32							
33							
34							
35							
36							
37							
38							
39							
40							

\* Must have the ability to bind the LIHTC entity; document with partnership/operating agreements and one 8609 (per entity/development) for a total of 6.

1st PAGE  
 TOTAL:            0            0            #DIV/0!  
 LIHTC as % of  
 Total Units

ADD ADDITIONAL PROPERTIES USING NEXT TAB

# List of LIHTC Developments (Schedule A)



Development Name: Westside Village Apartments  
 Name of Applicant: Westside Village Renewal LLC

**INSTRUCTIONS:**

- 1 **A Schedule A is required for every individual that makes up the GP or Managing Member** - does not apply to principals of publicly traded corporations.
- 2 For each property for which an uncorrected 8823 has been issued, provide a detailed explanation of the nature of the non-compliance, as well as a status statement.
- 3 List only tax credit development experience since 2004 (i.e. for the past 15 years)
- 4 Use separate pages as needed, for each principal.

Principal's Name: John Parreco Controlling GP (CGP) or 'Named' Managing Member of Proposed property? N  
Y or N

Development Name/Location	Name of Ownership Entity and Phone Number	CGP or 'Named' Managing Member at the time of dev.? (Y/N)*	Total Dev. Units	Total Low Income Units	Placed in Service Date	8609(s) Issue Date	Uncorrected 8823's? (Y/N) Explain "Y"
1	No Experience	Not Involved in Day to Day Operations	N/A	N/A	N/A	N/A	N/A
2							
3							
4							
5							
6							
7							
8							
9							
10							
11							
12							
13							
14							
15							
16							
17							
18							
19							
20							
21							
22							
23							
24							
25							
26							
27							
28							
29							
30							
31							
32							
33							
34							
35							
36							
37							
38							
39							
40							

\* Must have the ability to bind the LIHTC entity; document with partnership/operating agreements and one 8609 (per entity/development) for a total of 6.

1st PAGE  
 TOTAL:            0            0            #DIV/0!  
 LIHTC as % of  
 Total Units

ADD ADDITIONAL PROPERTIES USING NEXT TAB

E

Site Control  
Documentation & Most  
Recent Real Estate Tax  
Assessment  
(MANDATORY)

## **Site Control & Real Estate Tax Assessment**

Included in this section is Purchase and Sale Agreement between Westside Village Affordable LLC (Seller) and Westside Village Renewal LLC (Purchaser). A Real Estate Tax Assessment from 2019 for all eighteen buildings has also been included. The current owner, Westside Village Affordable LLC acquired the property from New Westside Village I Limited Partnership in February of 2020. The attached Real Estate Tax Assessments refer to the previous owner.

**REAL ESTATE PURCHASE AND SALE AGREEMENT**  
**(WESTSIDE VILLAGE APARTMENTS)**

THIS REAL ESTATE PURCHASE AND SALE AGREEMENT ("**Agreement**") is made and entered into as of the 13<sup>th</sup> day of February, 2020 ("**Contract Date**"), between **WESTSIDE VILLAGE RENEWAL LLC**, a Virginia limited liability company ("**Purchaser**"), and **WESTSIDE VILLAGE AFFORDABLE LLC**, a Virginia limited liability company ("**Seller**"), on the following terms and conditions, amending and restating in its entirety any previous agreement pertaining to the subject matter hereof:

**1. Agreement to Purchase and Sell.** Subject to and upon the terms and conditions hereinafter set forth, Purchaser hereby agrees to purchase from Seller and Seller hereby agrees to sell to Purchaser the property legally described in **Exhibit A** attached hereto (collectively, the "**Property**"). The Property consists of land together with any and all improvements thereon, any and all rights-of-way, easements, privileges and appurtenances pertaining thereto, if any, all right, title and interest of Seller, if any, in and to the fixtures, equipment and other personal property attached or appurtenant to the building or buildings, and any right, title and interest of Seller, if any, in and to any street, highway, road or alley adjoining any portion thereof.

**2. Purchase Price.**

**2.1. Amount.** The purchase price for the Property is Two Million Eight Hundred Thirty-Two Thousand One Hundred and 00/100 (\$2,832,100.00) (the "**Purchase Price**"). The purchase and sale of the Property is intended by the parties to be a sale of all elements of the Property, and is not severable or divisible, except as set forth in subsection 2.3.2 below. The Purchase Price shall be paid as provided in this Section 2.

**2.2. Deposits.** No earnest money deposits ("**Deposits**") shall be required unless required under other provisions of this Agreement.

**2.3. Payment at Closing.** At the Closing, Purchaser shall pay to Seller the following:

**2.3.1.** A promissory note in the principal amount of Ninety-Seven Thousand One Hundred and 00/100 Dollars (\$97,100.00) payable to Seller on the terms and conditions set forth therein (the "**Seller Note**"), which shall be secured by a mortgage or deed of trust on the Property, subject and subordinate to any senior financing; and

**2.3.2** An amount, in cash, equal to (A) the Purchase Price minus (B) the amount of the Seller Note; such difference to be subject to any credits, prorations, and other adjustments provided in this Agreement.

### 3. Survey.

3.1. Survey and Certificate. Seller shall obtain, at Seller's sole cost and expense, and deliver to Purchaser and Title Company within twenty-one (21) days after the Contract Date a current plat of survey of the Property (the "**Survey**") made by a Virginia licensed surveyor acceptable to Title Company and certified as having been made in compliance with the Minimum Standard Detailed Requirement for ALTA/ACSM Land Title Surveys jointly established by the American Land Title Association and the American Congress on Surveying and Mapping. The Survey shall also comply with the additional survey requirements set forth in **Exhibit B** attached hereto.

3.2. Recertification. If Title Company requires an updated Survey to issue at Closing the Title Policy and required endorsements described below, subject only to exceptions permitted under this Agreement, then Purchaser at its expense may cause the Survey to be updated and recertified as of a more current date acceptable to Title Company.

### 4. Title Insurance.

4.1. Commitment. Seller shall deliver or cause to be delivered to Purchaser or Purchaser's agent, at Seller's sole cost and expense, within thirty (30) days after the Contract Date, a title insurance commitment and copies of all documents referred to therein as conditions or exceptions to title to the Property (collectively, the "**Title Commitment**") for an ALTA owners title insurance policy with extended coverage to be given at Closing (the "**Title Policy**") issued by First American Title Insurance Company or another substantial title insurance company ("**Title Company**") in the amount of the Purchase Price, insuring title to the Property on or after the date hereof, showing title ownership in Seller subject only to (1) the "Permitted Exceptions" (as hereinafter defined) and (2) title exceptions pertaining to liens to encumbrances of a definite or ascertainable amount which may be removed by the payment of money at the time of Closing and which Seller may so remove at that time by using the funds to be paid upon the delivery of the deed to the Property. The Title Commitment shall be conclusive evidence of good title as therein shown as to all matters insured by the Title Policy, subject only to the exceptions or defects in title disclosed by the Survey, if any, as to which Title Company commits to insure over in the manner specified in Section 4.1.1 below, unless they are Permitted Exceptions.

4.1.1. If the Title Commitment or the Survey discloses title matters ("**Title Conditions**") or survey matters ("**Survey Defects**") (collectively, "**Exceptions**") that render title to the Property unmarketable or materially decrease its value or usefulness, Purchaser shall notify Seller in writing of its objections within fifteen (15) days after Purchaser has received both the Title Commitment and the Survey and Seller shall have thirty (30) days from the date of such notice to have the Exceptions removed from the Title Commitment or to have the Title Company commit to insure against loss or damage that may be occasioned by such Exceptions. Any Exceptions reflected on the Title Commitment or Survey to which Purchaser does not object by written notice given to Seller during said 15-day period shall be deemed "Permitted Exceptions." Real estate taxes to the extent not yet due and payable and all matters resulting from any act or failure to act of Purchaser shall also be Permitted Exceptions.

**4.1.2.** If Seller fails to have the Exceptions removed or, in the alternative, to obtain a commitment from Title Company to insure against loss or damage that may be occasioned by the Exceptions within the time herein specified, Purchaser may elect, upon written notice to Seller within ten (10) days after the expiration of the thirty (30) day period described above, either (1) to take title as it then is with the right to deduct from the Purchase Price liens or encumbrances of a definite or ascertainable amount or (2) to terminate this Agreement and receive a refund of all Deposits. If Purchaser does not so elect to terminate, Purchaser shall be deemed to have elected to take title as it then is.

**4.1.3.** In addition, to the extent Title Company is willing to issue the following, Seller shall provide and pay the premium cost for the endorsements for the Title Policy described in **Exhibit C** attached hereto and any endorsements reasonably required by Purchaser's mortgage lender (collectively, the "**Endorsements**"). Seller and Purchaser shall provide Title Company with such evidence of payment, undertakings or title indemnities as Title Company may require to insure Purchaser against loss from mechanics' and materialmen's liens that are not Permitted Exceptions relating to the Property, subject to the limitations, terms and conditions of this Agreement. Unavailability of any such coverage shall constitute an Exception subject to Section 4.1.1 if it affects title to the Property as described therein.

**4.2. Date-Down.** If Purchaser delivers a written request to Seller not more than ten (10) days and not less than five (5) days before Closing, Seller at its sole cost and expense shall cause the Title Commitment to be updated prior to Closing.

## **5. Representations and Warranties.**

**5.1. By Seller.** Seller, to induce Purchaser to enter into this Agreement and to purchase the Property, hereby represents and warrants to Purchaser as follows:

**5.1.1.** Seller has full power and authority to enter into this Agreement and to effect the transaction contemplated hereby, and the execution and delivery of this Agreement by the signatories hereto and the performance of this Agreement and the transactions contemplated hereunder by Seller has been duly authorized by all necessary action on the part of Seller.

**5.1.2.** Seller is, and to the best of its knowledge and belief Seller knows of no reason why it would not be treated as, a charitable organization exempt from federal income tax under Section 501(c)(3) and a "qualified nonprofit organization" under Section 42(h)(5)(c) of the Internal Revenue Code of 1986, as amended.

**5.1.3.** To the best of Seller's knowledge, there are not any easements or claims of easement or any right-of-way agreements not shown of record.

**5.1.4.** There are no oral agreements affecting the Property that will be in effect as of the Closing Date.



5.1.5. Seller has not received notice of any pending or threatened condemnation or similar proceedings affecting the Property nor, to the best of its knowledge are any such actions contemplated.

5.1.6. Neither Seller nor its agents or representatives have received any notices from any city, village or other governmental authority of environmental, zoning, building, fire, health code or other violations affecting the Property, that have not been corrected.

5.1.7. Seller covenants that without Purchaser's prior written consent, Seller will not (i) perform or permit any act which shall diminish, encumber, or affect Seller's rights in and to the Property or prevent Seller from fully performing its obligations hereunder; (ii) enter into any service contract affecting the Property or any part thereof unless the same is terminable without penalty by the owner of the Property upon not more than 30 days notice; nor (iii) withdraw, settle or otherwise compromise any protest or reduction proceeding affecting real estate taxes assessed against the Property.

5.1.8. Seller shall continue to operate the Property in the ordinary course of business as exists on the date hereof.

The representations and warranties contained in Section 5.1.1 shall survive Closing without limitation. Those contained in Sections 5.1.2 through 5.1.5 shall survive closing for a period of six (6) months after the Closing Date.

5.2. By Purchaser. Purchaser, to induce Seller to enter into this Agreement and to sell the Property, hereby represents and warrants to Seller as follows:

5.2.1. Purchaser has the full power and authority to enter into this Agreement and to effect the transaction contemplated hereby, and the execution and delivery of this Agreement by the signatories hereto and the performance of this Agreement and the transactions contemplated hereunder by Purchaser has been duly authorized by all necessary action on the part of Purchaser.

5.2.2. Purchaser intends to develop and operate the Property, with the material participation of Seller, as affordable rental housing qualifying for federal low-income housing tax credits.

The representations and warranties contained in this Section 5.2 shall survive Closing without limitation.

5.3. At Closing. If any of the representations and warranties made by Seller or Purchaser in this Agreement as of the Contract Date becomes no longer true and correct at any time hereafter until completion of the Closing (a "**Change**"), the party that made such representation and warranty ("**Declarant**") shall promptly give written notice of the Change to the other party ("**Recipient**"). If Recipient is aware of a Change earlier than Declarant, then Recipient promptly shall give written notice to Declarant of the Change. If Recipient reasonably determines that the Change is materially adverse to its interests under this Agreement, it shall notify Declarant in writing, within five (5) days after it first becomes aware of the Change, of its intent to terminate

this Agreement if the Change is not reversed or remedied. If Declarant does not reverse or remedy the Change to the reasonable satisfaction of Recipient within twenty (20) business days after written notice by Recipient to Declarant of Recipient's intent to terminate this Agreement, Recipient may at its option terminate this Agreement, and in such event all Deposits shall be returned to Purchaser; provided, however, that the Closing Date shall be extended if necessary to allow Declarant the full cure period of 20 business days. If the Change resulted from or was permitted to continue due to an intentional act or willful decision not to act on the part of Declarant, within its reasonable control or power to prevent, reverse or remedy, it shall constitute a default by Declarant under this Agreement. Notwithstanding the foregoing, in the event Purchaser is aware of a Change prior to the expiration of the Due Diligence Period but does not elect to terminate this Agreement prior to the Due Diligence Period expiring in accordance with the terms of Section 6.2.4, Purchaser will be deemed to approve all Changes it was aware of on or prior to expiration of the Due Diligence Period. Declarant's representations and warranties in this Agreement shall be deemed to have been remade at Closing, as of the Closing Date, and shall survive Closing for the same respective periods of time, if any, as the corresponding representations and warranties made as of the Contract Date, unless and to the extent Declarant properly notifies Recipient of the Change prior to Closing.

## **6. Due Diligence Conditions.**

**6.1. Due Diligence Period.** Purchaser shall have the period of time commencing on Contract Date and ending at 5:00 p.m. Eastern time on the day which is 180 days from the Contract Date (the "**Due Diligence Period**") to inspect diligently and thoroughly the Property, and to hire such experts as may be required to evaluate and analyze thoroughly the "Property Conditions" (as hereinafter defined) and satisfy the "Acquisition/Financing Conditions" (as hereinafter defined), including the hiring of contractors, engineers, soil analysts, pest control specialists, accountants, consultants, attorneys and the like, all at Purchaser's expense. Due Diligence Activities.

**6.2.** Purchaser shall have until the expiration of the Due Diligence Period within which to complete such tests, inspections, reviews and examinations of the Property as may be required to examine or obtain: (i) the conformity of the Property to past, current or future applicable zoning, building, subdivision, land use, health, safety, environmental, nondiscrimination or other laws, statutes, ordinances, rules, regulations, orders, codes or other legal requirements or with any past, present or future documents of record; (ii) the existence of soil instability, past soil repairs, soil additions or conditions of soil fill, or susceptibility to landslides; (iii) the sufficiency of any under shoring; (iv) the sufficiency of any drainage; (v) whether the Property is located wholly or partially in a flood plain or a flood hazard boundary or similar area; (vi) the existence or nonexistence of underground storage tanks; (vii) any other matter affecting the stability or integrity of the land, or any buildings or improvements situated on or as part of the Property; (viii) the availability of public utilities and services for the Property; (ix) the fitness or suitability of the Property for Purchaser's intended use, (10) the potential for further development of the Property; (x) the existence of vested land use, zoning, building or other entitlements affecting the Property; (xi) the ability of Purchaser to prepare plans and specifications and obtain and maintain licenses and permits for its intended use of the Property; (xii) the presence of toxic wastes, "Hazardous Materials" (as hereinafter defined) or friable or other asbestos in, on or about the Property (collectively, the "**Property Conditions**"), and (xiii) acquisition financing

of the Property by Purchaser from Seller in accordance with this Agreement and financing sufficient in Purchaser's judgment for the acquisition and the intended rehabilitation and operation of the Property, including without limitation a first mortgage loan provided by an acceptable lender on terms and conditions acceptable to Purchaser and an allocation of federal low-income housing tax credits from the Virginia Housing Development Authority (the "**Acquisition/Financing Conditions**"). Purchaser shall proceed with diligent efforts to obtain satisfaction of the Property Conditions and the Acquisition/Financing Conditions. If Seller reasonably determines that Purchaser is not proceeding diligently and Purchaser does not proceed with diligent efforts within ten (10) business days after written notice by Seller to Purchaser of Seller's intent to terminate this Agreement, Seller may at its option terminate this Agreement by written notice to Purchaser, and in such event all Deposits shall be returned to Purchaser.

**6.2.1.** Purchaser may conduct and prepare the following tests, studies, reports and preliminary plans not later than the Due Diligence Period expires, provided that Purchaser complies with Section 6.2.4 regarding Purchaser's entry onto the Property.

- Market Study;
- Site Plan;
- Subdivision Plan;
- Storm Water Detention Calculation;
- Preliminary Engineering Study;
- Soil Borings;
- Phase I Environmental Report; and
- Architectural Plans.

**6.2.2.** If Purchaser is unwilling to proceed with the transaction because Purchaser has determined that the Property Conditions are unsatisfactory or the Acquisition/Financing Conditions are unattainable, then Purchaser may terminate this Agreement by written notice to Seller given at any time on or before the expiration of the Due Diligence Period as to the Property Conditions or the Acquisition/Financing Conditions, whichever are applicable, and in such event any Deposits shall be returned to Purchaser. If Purchaser fails to notify Seller in writing of Purchaser's election to terminate this Agreement on or before the expiration of the Due Diligence Period, Purchaser shall be deemed to have waived its termination right for non-satisfaction of Due Diligence Conditions under this Section 6.2.3, and this Agreement shall remain in full force and effect. (The Property Conditions and the Acquisition/Financing Conditions are referred to collectively as the "**Due Diligence Conditions**").

**6.2.3.** On and after the Contract Date until the expiration of the Due Diligence Period or sooner termination of this Agreement, Purchaser and its agents and employees shall have the right to enter upon the Property during normal business hours for testing, surveying, engineering and other reasonable inspection purposes ("**Tests**"), and Purchaser shall defend, indemnify and hold the Seller, Original Seller, and their respective members, managers, employees and agents ("**Seller's Identified Parties**") harmless from any claims, demands, suits, liabilities, injuries, liens damages, losses, costs and expenses, including without limitation court costs and reasonable attorneys' fees and costs, for personal injury or property damage incurred by reason of, or arising out of, such entry upon

the Property or such Tests, except for any such matters caused primarily by Seller's or Original Seller's gross negligence or willful misconduct. Purchaser shall repair any damage to the Property arising from such entry and restore it to its original condition promptly after entry. Prior to entering the Property, if Seller so requires, Purchaser shall first obtain general public liability insurance in an amount of at least \$2,000,000.00 covering all individuals entering the property and naming Seller and Seller's Identified Parties as additional insureds, and shall provide a Certificate of Insurance to Seller. The terms of this Section 6.2.4 shall survive the Closing or termination of this Agreement.

## **7. Prorations, Adjustments, Closing Costs.**

**7.1. Prorations Generally.** All rents, other income, real estate taxes, insurance premiums, utility bills, other expenses, and other items which are customarily prorated between sellers and purchasers in commercial real estate transactions in Alabama shall be apportioned between Purchaser and Seller as of the date of Closing (the "**Proration Date**"). All such amounts shall be specified, if known, or reasonably estimated, if not yet known, and set forth in the Closing Statement, subject to re-proration when practicable.

**7.2. Rents.** Rental income shall be prorated on a cash basis as and when received, without regard to the month for which any rent payment is due, provided that Seller shall not accept any rent payments more than seven (7) days in advance of the month for which they are due. Any rental income applicable to the period ending on the Proration Date that is received by Purchaser after the Proration Date shall belong to Purchaser.

**7.3. Real Estate Taxes.** The real estate tax bill for Fiscal Year 2019 has been paid as of December 31, 2019, thus payment of real estate taxes are current. Up until the Closing Date, the Seller shall pay any subsequent tax bills as they come due. Real estate tax liability shall be prorated depending upon the Closing Date and the status of payments of real estate tax at the time of Closing.

**7.4. Title Insurance.** Seller shall pay the premium for the issuance of the Title Commitment and the Title Policy in the amount of the Purchase Price to be issued pursuant thereto (including the Endorsements) and the cost to update the Title Commitment as specified in Section 4, and Purchaser shall pay the amount of any premium charged by Title Company for the issuance of any additional endorsements to the Title Commitment or the Title Policy.

**7.5. Transfer Taxes.** Purchaser shall pay any real estate transfer or deed stamp taxes imposed by the State of Virginia, and any other governmental agency or municipality (including any locality) upon the transaction contemplated by this Agreement or the recordation of the deeds to be given by Seller pursuant to the terms of this Agreement. The real estate transfer, deed stamp taxes or recording costs for the deeds shall be paid by Purchaser out of Closing proceeds.

**7.6. Special Assessments.** Installment payments for any confirmed special assessment liens which are in effect as of the Closing, but which are not due and payable prior to the Closing, shall be prorated as of the Proration Date between Purchaser and Seller. Any special assessment liens which are unconfirmed as of the Closing shall be assumed and paid by Purchaser.

7.7. Closing Statement. The parties shall jointly prepare and deliver to each other at the Closing a "Closing Statement" which shall show the net amount due either to or from Seller or Purchaser, as the case may be, subject to final reparation, and such net amount will be added to, or subtracted from the payment of the cash balance of the Purchase Price to be paid to Seller pursuant to this Agreement.

8. Closing. The closing of the transaction contemplated by this Agreement (the "Closing") shall occur on a date selected by Purchaser no later than twenty-four (24) months after the Contract Date or such other date as the parties may agree in writing (the "Closing Date"), provided that Purchaser has not terminated this Agreement before then, pursuant to a right to do so specifically provided herein, at such location as the parties may agree in writing. Purchaser may extend the Closing Date for up to three (3) additional sixty (60) day periods upon written notice to Seller delivered at least fifteen (15) days before the Closing Date (or any extended Closing Date). In the event Purchaser elects to extend and gives notice, such extended date shall become the Closing Date.

9. Operation of Property Until Closing. Seller shall operate and maintain the Property until Closing in substantially the same manner and condition as currently, and shall not cause or knowingly permit any material adverse change to the Property, ordinary wear and tear, weather and acts of God excepted. Seller hereby represents and warrants that as of the Contract Date there are not any, and Seller hereby agrees that after the Contract Date, without Purchaser's prior written consent, Seller shall not enter into any, leases or other contracts affecting the Property that will be in effect on the Closing Date. Purchaser, prior to Closing, may cause its designated representatives to enter the Property upon prior notice to Seller provided that Purchaser first complies with Section 6.2.4 regarding Purchaser's entry onto the Property. The representatives and warranties contained in this Section 10 shall survive for a period of six (6) months after the Closing Date.

**10. Deliveries at Closing.**

10.1. By Seller. At Closing, Seller shall deliver the following to Purchaser:

10.1.1. One (1) Special Warranty Deed for the Property, in the form attached as Exhibit D hereto, subject only to the Permitted Exceptions;

10.1.2. Certification of Non-Foreign Status in the form prescribed by Section 1445(b)(2) of the Internal Revenue Code;

10.1.3. ALTA Statement executed by Seller, subject only to the Permitted Exceptions;

10.1.4. Such other instruments and documents as may be required by Title Company;

10.1.5. Possession of the Property subject only to the Permitted Exceptions.

**10.1.6.** Any and all authority documents that may be reasonably necessary in connection with the consummation of the transactions contemplated by this Agreement.

**10.2. By Purchaser.** At Closing, Purchaser shall deliver the following to Seller:

**10.2.1.** That portion of the Purchase Price set forth in Section 2.3.2 above, by wire transfer of good immediately available federal funds, plus or minus the debits, credits (including all Deposits) and other adjustments and prorrations which are made pursuant to this Agreement;

**10.2.2.** ALTA Statement executed by Purchaser, subject only to the Permitted Exceptions;

**10.2.3.** All instruments and documents to which Seller may be entitled under any of the other provisions of this Agreement; and

**10.2.4.** Such other instruments and documents as may be required by Title Company;

**10.3. Joint Deliveries.** At Closing, the parties shall jointly deliver the following:

**10.3.1.** Deed and Money Escrow Closing Instructions;

**10.3.2.** Real Estate Transfer Tax Declarations, in customary form; and

**10.3.3.** Closing Statement.

**10.4. Simultaneous Delivery.** The document deliveries specified to be delivered to the parties at Closing in Sections 10.1, 10.2, 10.3 and any other sections of this Agreement specifying deliveries at Closing shall be deemed to occur simultaneously and none of such deliveries shall be deemed to take place until all of such deliveries have taken place.

**11. Purchaser's Default.** If Purchaser defaults in any pre-Closing obligation hereunder, or fails to perform as provided herein, or if Closing fails to occur in a timely fashion for any reason except a default by Seller as set forth in Section 12 or because of Purchaser's timely termination for non-satisfaction of any of the Due Diligence Conditions, Seller's sole remedy shall be termination of this Agreement and recovery of all Deposits on deposit with Title Company as liquidated damages for such default.

**12. Seller's Default.** If Seller defaults in the performance of any of its obligations pursuant to this Agreement and Closing fails to occur by reason thereof, Purchaser may elect any of the following remedies: (1) termination of this Agreement and recovery of all Deposits on deposit with Title Company; (2) specific performance; (3) an action for damages for breach of contract; or (4) any other remedy available at law or in equity. Purchaser may elect to combine remedies (1) and (3) or any other remedies that are not inconsistent.

**13. Notices.** Any notices required or permitted to be given by this Agreement shall be in writing and mailed via certified mail, return receipt requested, postage prepaid, personally delivered, shipped via Federal Express or other "next day" courier delivery or sent by facsimile transmission with a copy by First Class Mail sent within one (1) business day after such transmission, as follows:

Purchaser: Westside Village Renewal LLC  
11810 Grand Park Avenue, Suite 600  
North Bethesda, MD 20852  
Attention: Todd Travis  
Facsimile No.: (301) 998-0401

Seller: Westside Village Affordable LLC  
11810 Grand Park Avenue, Suite 600  
North Bethesda, MD 20852  
Attention: Randall Kelley  
Facsimile No.: (301) 998-0425

Notice duly delivered in the manner described above shall be deemed received upon the earliest of the following to occur: actual receipt; transmission by facsimile with printed information of receipt; the next succeeding Business Day after shipping by Federal Express as aforesaid; or the second Business Day after mailing by certified mail as aforesaid. The parties shall promptly give written notice to each other as provided in this Section 14 of any change of address or facsimile number, and personal delivery, mailing, shipment to the addresses or facsimile transmission to the numbers set forth above shall be deemed sufficient unless written notification of a change of address or facsimile number has been received. If any notice is actually received on a day which is not a Business Day, such notice shall be deemed given on the next succeeding Business Day.

**14. Survival of Obligations.** All covenants, representations, warranties, agreements and indemnities contained in this Agreement are made as of the Contract Date. Such covenants, representations, warranties, agreements and indemnities shall not survive Closing except to the extent specifically stated herein.

**15. Counterparts.** This Agreement may be executed in several counterparts, and all so executed shall constitute one agreement, binding upon all of the parties hereto, notwithstanding that all of the parties are not signatories to the original or the same counterpart; provided, however, that this Agreement shall not be binding upon any party or signatory hereto until each person or entity which is to execute this Agreement has so executed a counterpart thereof.

**16. Further Assurances.** Each party shall execute such further documents, papers and instruments and take such further action as is necessary, appropriate or helpful as the other party or Title Company may reasonably request in order to carry out the purposes and intent of this Agreement.

**17. Assignment.** Purchaser may assign its rights under this Agreement to a limited liability company of which Purchaser serves as managing member. Purchaser shall promptly notify Seller of any such assignment. No other assignment of Purchaser's rights under this Agreement is permitted without Seller's prior written consent, which Seller may withhold in its sole discretion.

**18. Exclusivity:** Subject to the Provisions of Section 17 above, this is an exclusive agreement by and between Seller and Purchaser. No other offers will be considered.

*[The remainder of this page left intentionally blank.  
Signature pages follow.]*



IN WITNESS WHEREOF, Purchaser and Seller have executed this Agreement as of the date first above written.

**PURCHASER:**

**WESTSIDE VILLAGE RENEWAL LLC,**  
a Virginia limited liability company

By: Westside Village Manager LLC, a Virginia  
limited liability company  
Its managing member

By: Huntington Housing, Inc., a Maryland nonprofit  
corporation, its sole member and manager

By:   
\_\_\_\_\_  
Todd Travis, President

**SELLER:**

**WESTSIDE VILLAGE AFFORDABLE LLC**  
a Virginia limited liability company

By: Echelon Housing, Inc., a Maryland nonprofit  
corporation, its sole member and manager

By:   
\_\_\_\_\_  
Cassandra Palanza, Secretary

## EXHIBIT A

### Legal Description of Property

All that certain tract or parcel of land, with improvements and appurtenances thereunto belonging, lying and being situated in Banister District of Halifax County, Virginia, fronting 729.32 feet on the westerly boundary of Virginia State Highway No. 654, and described more particularly as follows:

Beginning at a new iron pipe in the westerly margin of the proposed Westside Drive, thence along the westerly margin of Virginia State Highway No. 654 S.  $50^{\circ} 48' 18''$  E 729.32 feet to an existing iron pipe in the westerly margin of Virginia State Highway No. 654 and the northern line of property now or formerly owned by James Martin; thence along the northern line of the Martin Property S.  $65^{\circ} 02' 50''$  W. 673.50 feet to a new iron pipe, a corner in Martin's northern line; thence leaving

Martin's northern line along a new line N.  $36^{\circ} 04' 25''$  W. 425.45 feet to a new iron; thence along a new line N.  $53^{\circ} 55' 35''$  E. 34.30 feet to a new iron pipe; thence along a new line N.  $15^{\circ} 46' 45''$  W. 159.93 feet to a new iron pipe in the southern margin of the proposed Westside Drive; thence along the southern margin of the proposed Westside Drive N.  $53^{\circ} 55' 35''$

E. 385.63 feet to a new iron pipe at the point of beginning, and containing 8 acres or 348.480 square feet.



CURRENT OWNER		TOPO	UTILITIES	STRT / ROAD	ZONING	CURRENT ASSESSMENT					
NEW WESTSIDE VILLAGE I LIMITED PARTNERSHIP % T M ASS. MGMT INC 1375 PICCARD DR STE 150		0 Unknown	0 All Public Utiliti	0 Paved		Describe	Co	LU MRKT Value	Appraised	Assessed	
		0 Level	0 Unknown			Building	400	0	2,111,500	2,111,500	
		0 Unknown	0 Unknown			Land	400	0	272,800	272,800	
		<b>SUPPLEMENTAL DATA</b>			Outbldg	400	0	25,700	25,700		
ROCKVILLE MD 20850		Plat	NBHD Cod T17-8:South Boston - B		Lister Date						
		Info By	E:Estimated Informatio		Mobile Ho	0					
		Exempt	00:No		Tracts	0					
		Total Acre	8		Road Num	654					
		Lister			Gis ID	059-01-00-0001					
Parcel Description WESTSIDE VILLAGE APTS.						Total			2,410,000	2,410,000	
						Total Appraised Land			272,800		

RECORD OF OWNERSHIP							WILL BK/PG	INSTRUMENT	BK-VOL/PAGE	SALE DATE	Q	SALE PR	PREVIOUS ASSESSMENTS (HISTORY)										
NEW WESTSIDE VILLAGE I LIMITED							0	0	10-533	1063	761	02-26-2010	Q	1,400,00	Year	Code	Assessed	Year	Code	Assessed	Year	Co	Assessed
WESTSIDE VILLAGE ASSOCIATES							0	0		0	0	01-01-2010		0	2018	400	2,111,500	2017	400	2,111,500	2016	400	2,111,500
							0	0							400	272,800		400	272,800		400	272,800	
							0	0							400	25,700		400	25,700		400	25,700	
													Total	2410000		Total	2410000		Total	2410000			

EXEMPTIONS				OTHER ASSESSMENTS				AG DISTRICT					
Year	Code	Description	Amount	Code	Description	Number	Amount	Comm	Int				
			Total	0.00									

ASSESSING NEIGHBORHOOD				
NBHD	NBHD Name	Street Index Name	District Code	Class Code
0001			T17	04

NOTES				

APPRAISED VALUE SUMMARY				
Appraised Bldg. Value (Card)				2,111,500
Appraised XF (B) Value (Bldg)				0
Appraised OB (B) Value (Bldg)				25,700
Appraised Land Value				272,800
Special Land Value				0
Total Appraised Parcel Value				2,410,000
Valuation Method				C
Exemption				0
Adjustment				
Total Appraised Parcel Value				2,410,000

VISIT / CHANGE HISTORY						
Date	Type	IS	ID	Cd	Purpose/Result	Notes
03-17-2017			TS	18	REASSESSMENT	
09-15-2015			PH	RE	REASSESSMENT	2016 N/C
09-15-2015	3		PH	BP	BUILDING PERMI	2016: permit 11571 FOR FIRE DAMAGE AND ELECTRICAL - NO CHANGE.

LAND LINE VALUATION SECTION																					
B	Use co	Description	Zone	D	Land	Land Type	Units	Unit Price	I. Fact	S.A.	Ac Di	C. Fact	St. Idx	Adj	Notes	Special Pricing	Size	Adj Unit Pric	Land Value		
1	400R	Comm - Indl -			40	Comm/Ind	8.000	AC	1.000	5	1.000	1.00	O	1.00	A - ACREAGE		0	1.000	34,100.00	272,800	
Total Card Land Units							8.000	AC	Parcel Total Land Area			8.0000								Total Land Value	272,800

CONSTRUCTION DETAIL			CONSTRUCTION DETAIL (CONTINUED)		
Element	Cd	Description	Element	Cd	Description
Model	01	Residential	Chimney - 1P		
Building Class	30	COMMERCIAL	Chimney - 2M		
Style	006	WALKUP APARTMENT	Chimney - 2P		
Grade	24	C			
Foundation Ty	BR	Brick			
Exterior Wall 1	02	Brick Veneer			
Exterior Wall 2	01	Wood Lap Siding			
Roof Structure	01	Gable			
Roof Cover 1	01	Composition Shingle			
Roof Cover 2					
Interior Wall 1	01	Dry Wall			
Interior Wall 2					
Interior Floor 1	01	Carpet			
Interior Floor 2	02	Vinyl			
Interior Floor 3					
Fuel Type 1	E	Electric			
Fuel Type 2					
Heat Type 1	01	Central Heat			
Heat Type 2					
AC Type	02	Central Air			
Total Rooms	4				
Bedrooms	0				
Full Bath(s)	8				
Full Bath Grad	C				
Half Bath(s)	0				
Half Bath Grad					
Extra Fixture(s)		Average Quality Constructi			
Extra Fix Grad					
Fireplace Ope	0				
Fireplace(s)					
Chimney - 1M					
Chimnev - 1P					

MIXED USE		
Code	Description	Percentage
400R	Comm - Incl - Res	100
		0
		0

COST / MARKET VALUATION		
Base Rate		45.18
RCN		135,510
Net Other Adj		26,402
RCN		135,510
AYB		1975
Effective Year Built		
Depreciation Code		A
Remodel Rating		
Year Remodeled		
EYB DPR	20	
Functional Obsol	0	
Economic Obsol		
Cost Trend Factor	1	
Condition		
% Complete	80	
RCNLD		2,111,500
Dep % Ovr		
Dep Ovr Comment		
Misc Imp Ovr		
Misc Imp Ovr Comment		
Cost to Cure Ovr		
Cost to Cure Ovr Comment		

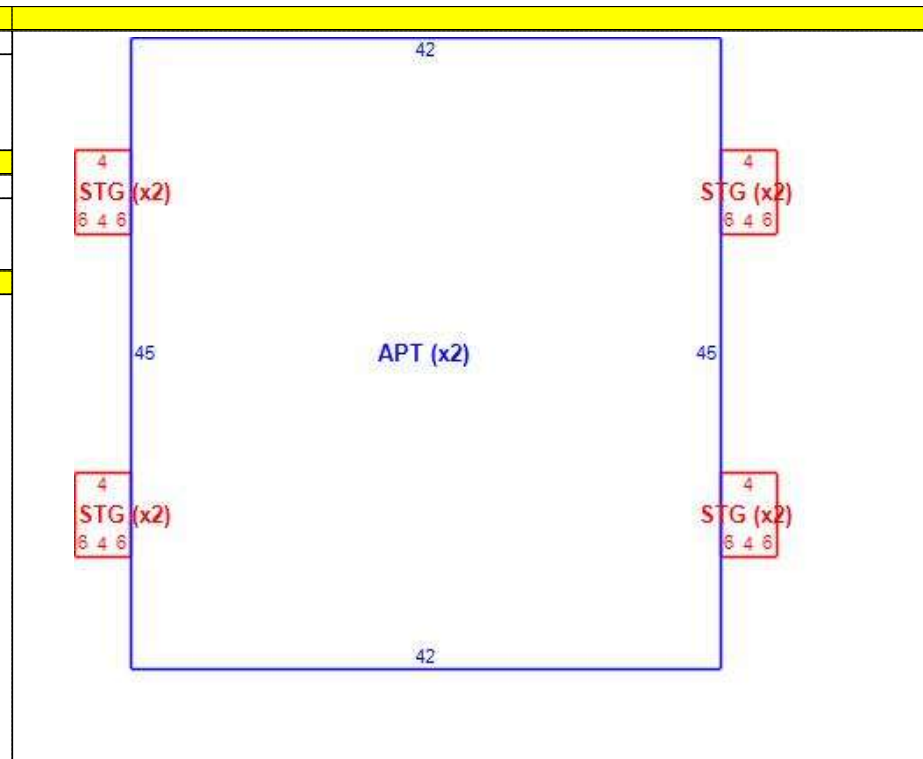

OB - OUTBUILDING & YARD ITEMS(L) / XF - BUILDING EXTRA FEATURES(B)											
Code	Description	Su	Sub Desc	Lan	Units	Unit Price	Year	%	Cond	#	Apprais Valu
ASPL	Asphalt			L	0	0.96	2014	100	A	1	12,000
MI	Miscellaneous			L	0	1.00	2014	100	A	1	10,000

BUILDING SUB-AREA SUMMARY SECTION						
SUBAR	Description	LIVING	GROSS	EFF AR		
APT	Apartment	3,780	3,780	2,079		
STG	Storage	0	192	31		
Ttl Gross Liv / Lease Area		3,780	3,972	2,110		



CURRENT OWNER			TOPO	UTILITIES	STRT / ROAD	ZONING	CURRENT ASSESSMENT				
NEW WESTSIDE VILLAGE I LIMITED PARTNERSHIP % T M ASS. MGMT INC 1375 PICCARD DR STE 150			0 Unknown	0 All Public Utiliti	0 Paved		Describe	Co	LU MRKT Value	Appraised	Assessed
			0 Level	0 Unknown			Building	400	0	2,111,500	2,111,500
			0 Unknown	0 Unknown			Land	400	0	272,800	272,800
			<b>SUPPLEMENTAL DATA</b>				Outldg	400	0	25,700	25,700
			Plat	Lister Date							
			NBHD Cod T17-8:South Boston - B	Mobile Ho 0							
			Info By E:Estimated Informatio								
			Exempt 00:No	Tracts 0							
			Total Acre 8	Road Num 654							
ROCKVILLE MD 20850			Lister	Gis ID 059-01-00-0001							
Parcel Description WESTSIDE VILLAGE APTS.							Total		2,410,000		2,410,000
							Total Appraised Land			272,800	

RECORD OF OWNERSHIP							WILL BK/PG	INSTRUMENT	BK-VOL/PAGE	SALE DATE	Q/	SALE PR	PREVIOUS ASSESSMENTS (HISTORY)								
NEW WESTSIDE VILLAGE I LIMITED							0 0	10-533	1063 761	02-26-2010	Q	1,400,00	Year	Code	Assessed	Year	Code	Assessed	Year	Co	Assessed
WESTSIDE VILLAGE ASSOCIATES							0 0		0 0	01-01-2010		0	2018	400	2,111,500	2017	400	2,111,500	2016	400	2,111,500
							0 0							400	272,800		400	272,800		400	272,800
							0 0							400	25,700		400	25,700		400	25,700
												Total	2410000		Total	2410000		Total	2410000		

EXEMPTIONS				OTHER ASSESSMENTS				AG DISTRICT				
Year	Code	Description	Amount	Code	Description	Number	Amount	Comm Int				
			Total					0.00				

ASSESSING NEIGHBORHOOD					
NBHD	NBHD Name	Street Index Name	District Code	Class Code	
0001			T17	04	

NOTES															

VISIT / CHANGE HISTORY															
Date	Type	IS	ID	Cd	Purpose/Result	Notes									

LAND LINE VALUATION SECTION																					
B	Use co	Description	Zone	D	Land	Land Type	Units	Unit Price	I. Fact	S.A.	Ac Di	C. Fact	St. Idx	Adj	Notes	Special Pricing	Size	Adj Unit Pric	Land Value		
2	400R	Comm - Incl -					0.000	AC	1.00	1.000	5	1.00		1.00			0	1.000	1.00	0	
Total Card Land Units							0.000	AC	Parcel Total Land Area			8.0000								Total Land Value	0

CONSTRUCTION DETAIL			CONSTRUCTION DETAIL (CONTINUED)		
Element	Cd	Description	Element	Cd	Description
Model	01	Residential	Chimney - 1P		
Building Class	30	COMMERCIAL	Chimney - 2M		
Style	006	WALKUP APARTMENT	Chimney - 2P		
Grade	24	C			
Foundation Ty	BR	Brick			
Exterior Wall 1	02	Brick Veneer			
Exterior Wall 2	01	Wood Lap Siding			
Roof Structure	01	Gable			
Roof Cover 1	01	Composition Shingle			
Roof Cover 2					
Interior Wall 1	01	Dry Wall			
Interior Wall 2					
Interior Floor 1	01	Carpet			
Interior Floor 2	02	Vinyl			
Interior Floor 3					
Fuel Type 1	E	Electric			
Fuel Type 2					
Heat Type 1	01	Central Heat			
Heat Type 2					
AC Type	02	Central Air			
Total Rooms	4				
Bedrooms	0				
Full Bath(s)	8				
Full Bath Grad	C				
Half Bath(s)	0				
Half Bath Grad					
Extra Fixture(s)		Average Quality Constructi			
Extra Fix Grad					
Fireplace Ope	0				
Fireplace(s)					
Chimney - 1M					
Chimnev - 1P					

MIXED USE		
Code	Description	Percentage
400R	Comm - Indl - Res	100
		0
		0

COST / MARKET VALUATION		
Base Rate		45.18
RCN		135,510
Net Other Adj		26,402
RCN		135,510
AYB		1975
Effective Year Built		
Depreciation Code		A
Remodel Rating		
Year Remodeled		
EYB DPR	20	
Functional Obsol	0	
Economic Obsol		
Cost Trend Factor	1	
Condition		
% Complete		80
RCNLD		0
Dep % Ovr		
Dep Ovr Comment		
Misc Imp Ovr		
Misc Imp Ovr Comment		
Cost to Cure Ovr		
Cost to Cure Ovr Comment		

OB - OUTBUILDING & YARD ITEMS(L) / XF - BUILDING EXTRA FEATURES(B)											
Code	Description	Su	Sub Desc	Lan	Units	Unit Price	Year	%	Cond	#	Apprais Valu

BUILDING SUB-AREA SUMMARY SECTION						
SUBAR	Description	LIVING	GROSS	EFF AR		
APT	Apartment	3,780	3,780	2,079		
STG	Storage	0	192	31		
Ttl Gross Liv / Lease Area		3,780	3,972	2,110		

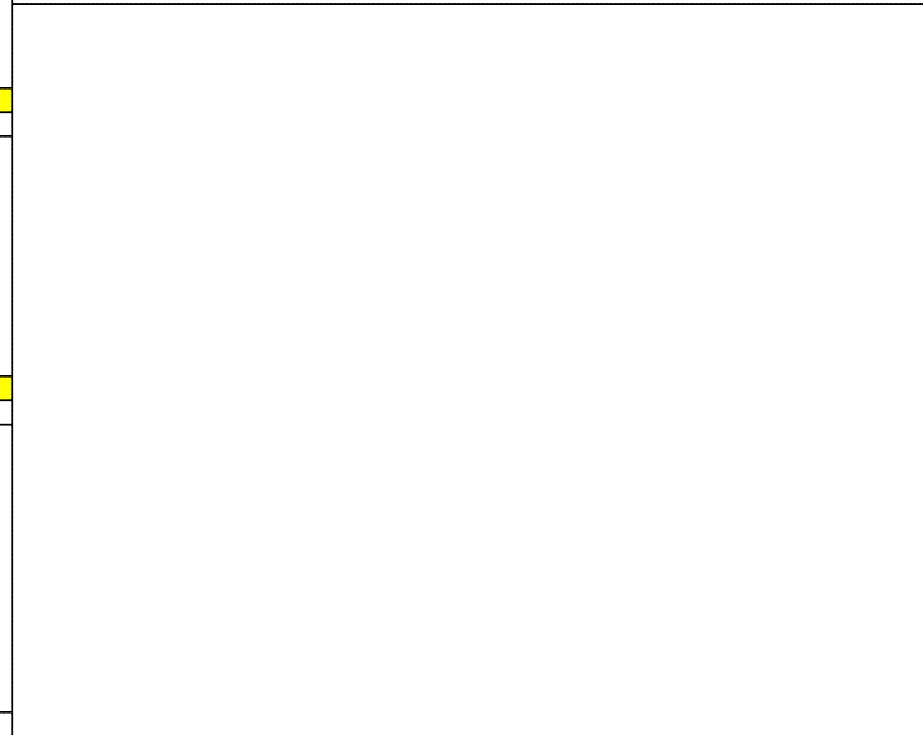
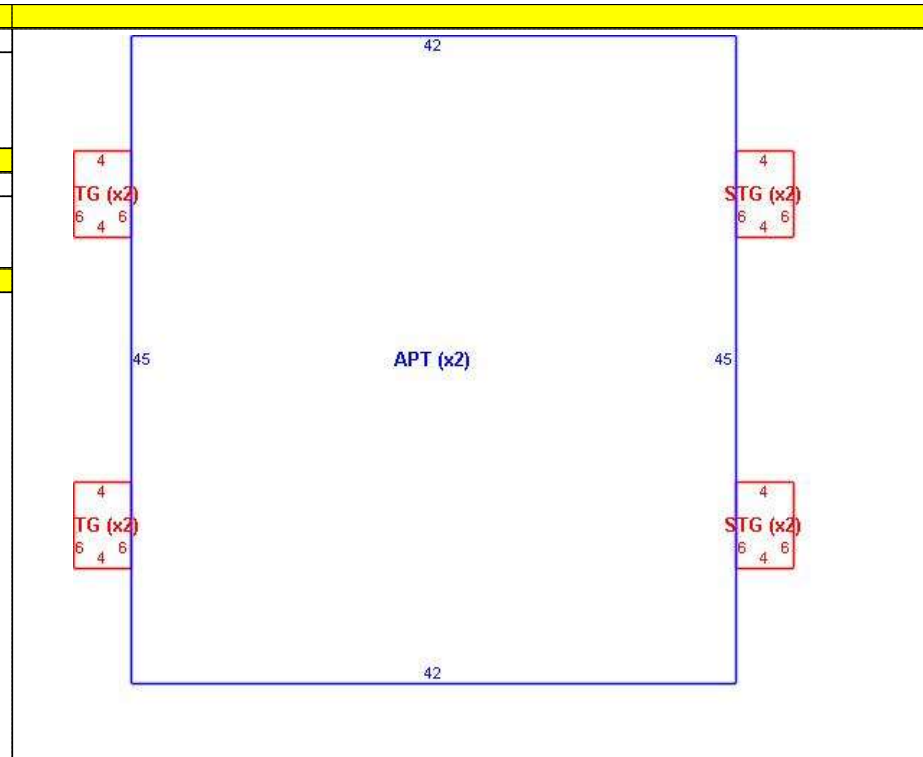

CURRENT OWNER			TOPO	UTILITIES	STRT / ROAD	ZONING	CURRENT ASSESSMENT				
NEW WESTSIDE VILLAGE I LIMITED PARTNERSHIP % T M ASS. MGMT INC 1375 PICCARD DR STE 150  ROCKVILLE MD 20850			0 Unknown	0 All Public Utiliti	0 Paved		Describe	Co	LU MRKT Value	Appraised	Assessed
			0 Level	0 Unknown			Building	400	0	2,111,500	2,111,500
			0 Unknown	0 Unknown			Land	400	0	272,800	272,800
<b>SUPPLEMENTAL DATA</b>							Outbldg	400	0	25,700	25,700
			Plat	Lister Date							
			NBHD Cod T17-8:South Boston - B	Mobile Ho 0							
			Info By E:Estimated Informatio								
			Exempt 00:No	Tracts 0							
			Total Acre 8	Road Num 654							
			Lister	Gis ID 059-01-00-0001							
Total									2,410,000	2,410,000	

Parcel Description WESTSIDE VILLAGE APTS. Total Appraised Land 272,800

RECORD OF OWNERSHIP							WILL BK/PG	INSTRUMENT	BK-VOL/PAGE	SALE DATE	Q/	SALE PR	PREVIOUS ASSESSMENTS (HISTORY)					
Year	Code	Assessed	Year	Code	Assessed	Year	Co	Assessed										
2018	400	2,111,500	2017	400	2,111,500	2016	400	2,111,500										
	400	272,800		400	272,800		400	272,800										
	400	25,700		400	25,700		400	25,700										
Total		2410000	Total		2410000	Total		2410000										

EXEMPTIONS				OTHER ASSESSMENTS			
Year	Code	Description	Amount	Code	Description	Number	Amount
Total			0.00				

AG DISTRICT			
APPRAISED VALUE SUMMARY			
Appraised Bldg. Value (Card)		2,111,500	
Appraised XF (B) Value (Bldg)		0	
Appraised OB (B) Value (Bldg)		25,700	
Appraised Land Value		272,800	
Special Land Value		0	
Total Appraised Parcel Value		2,410,000	
Valuation Method		C	
Exemption		0	
Adjustment			
Total Appraised Parcel Value		2,410,000	

ASSESSING NEIGHBORHOOD					
NBHD	NBHD Name	Street Index Name	District Code	Class Code	
0001			T17	04	

NOTES						

VISIT / CHANGE HISTORY																		
Date	Type	IS	ID	Cd	Purpose/Result	Notes												

LAND LINE VALUATION SECTION																				
B	Use co	Description	Zone	D	Land	Land Type	Units	Unit Price	I. Fact	S.A.	Ac Di	C. Fact	St. Idx	Adj	Notes	Special Pricing	Size	Adj Unit Pric	Land Value	
3	400R	Comm - Incl -					0.000	AC	1.00	1.000	5	1.00		1.00			0	1.000	1.00	0
Total Card Land Units							0.000	AC	Parcel Total Land Area			8.0000	Total Land Value							0



CONSTRUCTION DETAIL			CONSTRUCTION DETAIL (CONTINUED)		
Element	Cd	Description	Element	Cd	Description
Model	01	Residential	Chimney - 1P		
Building Class	30	COMMERCIAL	Chimney - 2M		
Style	006	WALKUP APARTMENT	Chimney - 2P		
Grade	24	C			
Foundation Ty	BR	Brick			
Exterior Wall 1	02	Brick Veneer			
Exterior Wall 2	01	Wood Lap Siding			
Roof Structure	01	Gable			
Roof Cover 1	01	Composition Shingle			
Roof Cover 2					
Interior Wall 1	01	Dry Wall			
Interior Wall 2					
Interior Floor 1	01	Carpet			
Interior Floor 2	02	Vinyl			
Interior Floor 3					
Fuel Type 1	E	Electric			
Fuel Type 2					
Heat Type 1	01	Central Heat			
Heat Type 2					
AC Type	02	Central Air			
Total Rooms	4				
Bedrooms	0				
Full Bath(s)	8				
Full Bath Grad	C				
Half Bath(s)	0				
Half Bath Grad					
Extra Fixture(s)		Average Quality Constructi			
Extra Fix Grad					
Fireplace Ope	0				
Fireplace(s)					
Chimney - 1M					
Chimnev - 1P					

MIXED USE		
Code	Description	Percentage
400R	Comm - Indl - Res	100
		0
		0

COST / MARKET VALUATION		
Base Rate		45.18
RCN		135,510
Net Other Adj		26,402
RCN		135,510
AYB		1975
Effective Year Built		
Depreciation Code	A	
Remodel Rating		
Year Remodeled		
EYB DPR	20	
Functional Obsol	0	
Economic Obsol		
Cost Trend Factor	1	
Condition		
% Complete	80	
RCNLD	0	
Dep % Ovr		
Dep Ovr Comment		
Misc Imp Ovr		
Misc Imp Ovr Comment		
Cost to Cure Ovr		
Cost to Cure Ovr Comment		

OB - OUTBUILDING & YARD ITEMS(L) / XF - BUILDING EXTRA FEATURES(B)											
Code	Description	Su	Sub Desc	Lan	Units	Unit Price	Year	%	Cond	#	Apprais Valu

BUILDING SUB-AREA SUMMARY SECTION						
SUBAR	Description	LIVING	GROSS	EFF AR		
APT	Apartment	3,780	3,780	2,079		
STG	Storage	0	192	31		
Ttl Gross Liv / Lease Area		3,780	3,972	2,110		

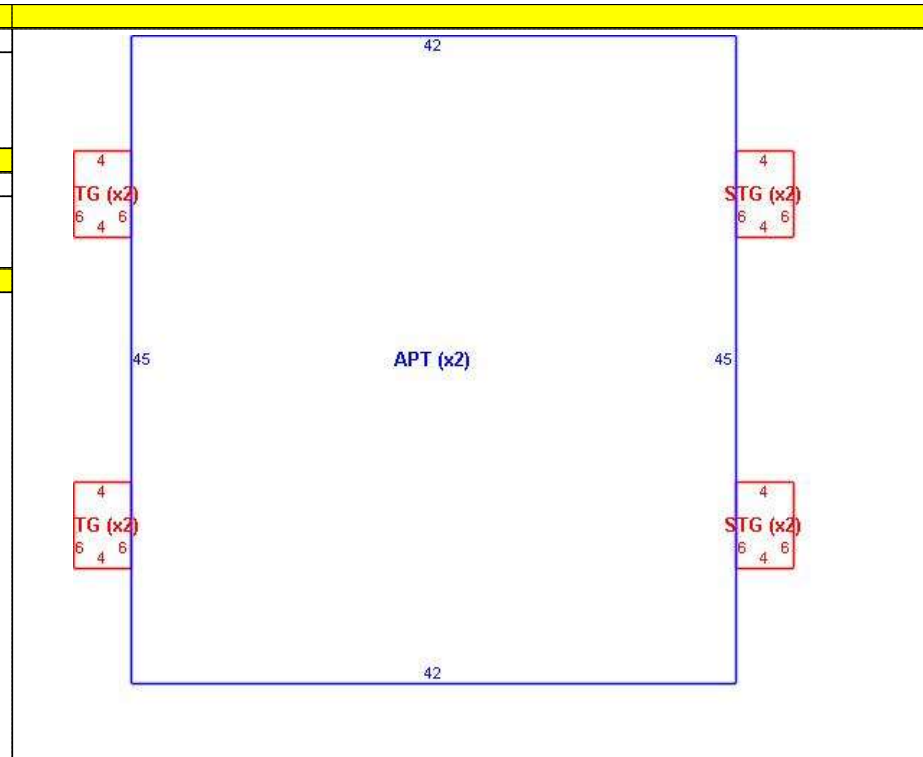

CURRENT OWNER			TOPO	UTILITIES	STRT / ROAD	ZONING	CURRENT ASSESSMENT				
NEW WESTSIDE VILLAGE I LIMITED PARTNERSHIP % T M ASS. MGMT INC 1375 PICCARD DR STE 150  ROCKVILLE MD 20850			0 Unknown	0 All Public Utiliti	0 Paved		Describe	Co	LU MRKT Value	Appraised	Assessed
			0 Level	0 Unknown			Building	400	0	2,111,500	2,111,500
			0 Unknown	0 Unknown			Land	400	0	272,800	272,800
<b>SUPPLEMENTAL DATA</b>							Outbldg	400	0	25,700	25,700
Plat			NBHD Cod T17-8:South Boston - B			Lister Date					
Info By			E:Estimated Informatio			Mobile Ho 0					
Exempt 00:No			Tracts 0			Road Num 654					
Total Acre 8			Road Num 654			Gis ID 059-01-00-0001					
Lister											
							Total		2,410,000		2,410,000

Parcel Description WESTSIDE VILLAGE APTS. Total Appraised Land 272,800

RECORD OF OWNERSHIP							WILL BK/PG	INSTRUMENT	BK-VOL/PAGE	SALE DATE	Q/	SALE PR	PREVIOUS ASSESSMENTS (HISTORY)					
Year	Code	Assessed	Year	Code	Assessed	Year	Co	Assessed	Year	Co	Assessed							
2018	400	2,111,500	2017	400	2,111,500	2016	400	2,111,500	2016	400	2,111,500							
	400	272,800		400	272,800		400	272,800		400	272,800							
	400	25,700		400	25,700		400	25,700		400	25,700							
Total		2410000	Total		2410000	Total		2410000	Total		2410000							

EXEMPTIONS				OTHER ASSESSMENTS			
Year	Code	Description	Amount	Code	Description	Number	Amount
Total			0.00				

AG DISTRICT			
APPRAISED VALUE SUMMARY			
Appraised Bldg. Value (Card)		2,111,500	
Appraised XF (B) Value (Bldg)		0	
Appraised OB (B) Value (Bldg)		25,700	
Appraised Land Value		272,800	
Special Land Value		0	
Total Appraised Parcel Value		2,410,000	
Valuation Method		C	
Exemption		0	
Adjustment			
Total Appraised Parcel Value		2,410,000	

ASSESSING NEIGHBORHOOD				
NBHD	NBHD Name	Street Index Name	District Code	Class Code
0001			T17	04

NOTES						

LAND LINE VALUATION SECTION																				
B	Use co	Description	Zone	D	Land	Land Type	Units	Unit Price	I. Fact	S.A.	Ac Di	C. Fact	St. Idx	Adj	Notes	Special Pricing	Size	Adj Unit Pric	Land Value	
4	400R	Comm - Incl -					0.000 AC	1.00	1.000	5		1.00		1.00			0	1.000	1.00	0
Total Card Land Units							0.000 AC	Parcel Total Land Area			8.0000								Total Land Value	0

**CONSTRUCTION DETAIL** **CONSTRUCTION DETAIL (CONTINUED)**

Element	Cd	Description	Element	Cd	Description
Model	01	Residential	Chimney - 1P		
Building Class	30	COMMERCIAL	Chimney - 2M		
Style	006	WALKUP APARTMENT	Chimney - 2P		
Grade	24	C			
Foundation Ty	BR	Brick	<b>MIXED USE</b>		
Exterior Wall 1	02	Brick Veneer	Code	Description	Percentage
Exterior Wall 2	01	Wood Lap Siding	400R	Comm - Incl - Res	100
Roof Structure	01	Gable			0
Roof Cover 1	01	Composition Shingle			0
Roof Cover 2			<b>COST / MARKET VALUATION</b>		
Interior Wall 1	01	Dry Wall	Base Rate		45.18
Interior Wall 2			RCN		135,510
Interior Floor 1	01	Carpet	Net Other Adj		26,402
Interior Floor 2	02	Vinyl	RCN		135,510
Interior Floor 3			AYB		1975
Fuel Type 1	E	Electric	Effective Year Built		
Fuel Type 2			Depreciation Code		A
Heat Type 1	01	Central Heat	Remodel Rating		
Heat Type 2			Year Remodeled		
AC Type	02	Central Air	EYB DPR	20	
Total Rooms	4		Functional Obsol	0	
Bedrooms	0		Economic Obsol		
Full Bath(s)	8		Cost Trend Factor	1	
Full Bath Grad	C		Condition		
Half Bath(s)	0		% Complete		80
Half Bath Grad			RCNLD		0
Extra Fixture(s)		Average Quality Constructi	Dep % Ovr		
Extra Fix Grad			Dep Ovr Comment		
Fireplace Ope	0		Misc Imp Ovr		
Fireplace(s)			Misc Imp Ovr Comment		
Chimney - 1M			Cost to Cure Ovr		
Chimnev - 1P			Cost to Cure Ovr Comment		

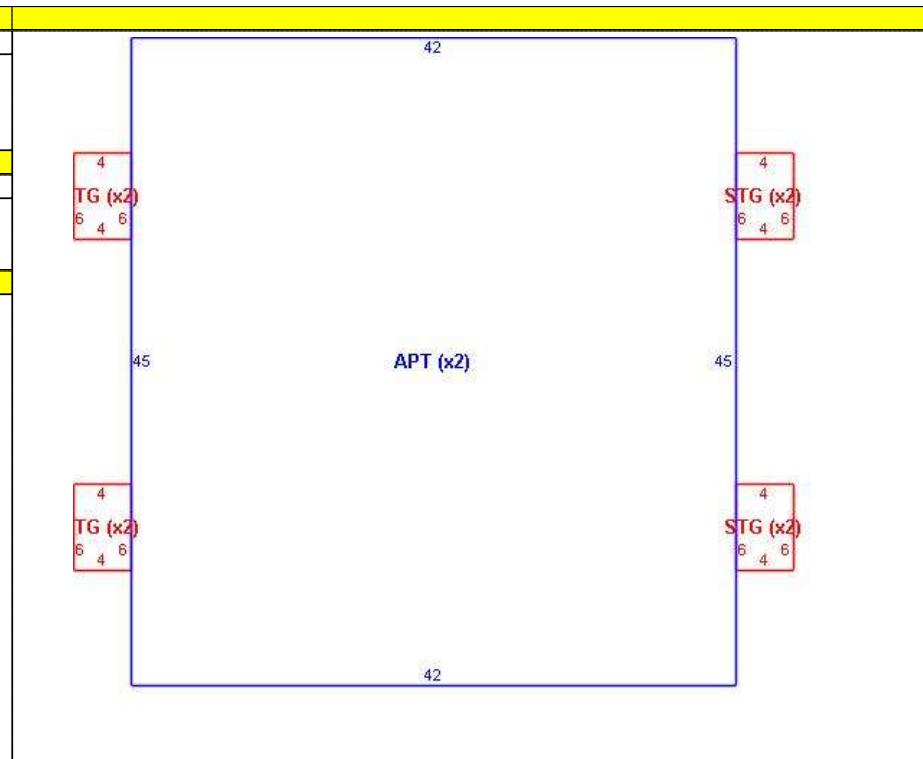

**OB - OUTBUILDING & YARD ITEMS(L) / XF - BUILDING EXTRA FEATURES(B)**

Code	Description	Su	Sub Desc	Lan	Units	Unit Price	Year	%	Cond	#	Apprais Valu

**BUILDING SUB-AREA SUMMARY SECTION**

SUBAR	Description	LIVING	GROSS	EFF AR
APT	Apartment	3,780	3,780	2,079
STG	Storage	0	192	31
Ttl Gross Liv / Lease Area		3,780	3,972	2,110

CURRENT OWNER			TOPO	UTILITIES	STRT / ROAD	ZONING	CURRENT ASSESSMENT				
NEW WESTSIDE VILLAGE I LIMITED PARTNERSHIP % T M ASS. MGMT INC 1375 PICCARD DR STE 150  ROCKVILLE MD 20850			0 Unknown	0 All Public Utiliti	0 Paved		Describe	Co	LU MRKT Value	Appraised	Assessed
			0 Level	0 Unknown			Building	400	0	2,111,500	2,111,500
			0 Unknown	0 Unknown			Land	400	0	272,800	272,800
<b>SUPPLEMENTAL DATA</b>											
			Plat	Lister Date							
			NBHD Cod T17-8:South Boston - B	Mobile Ho 0							
			Info By E:Estimated Informatio								
			Exempt 00:No	Tracts 0							
			Total Acre 8	Road Num 654							
			Lister	Gis ID 059-01-00-0001							
Total										2,410,000	2,410,000

Parcel Description WESTSIDE VILLAGE APTS. Total Appraised Land 272,800

RECORD OF OWNERSHIP							PREVIOUS ASSESSMENTS (HISTORY)										
WILL BK/PG	INSTRUMENT	BK-VOL/PAGE	SALE DATE	Q	SALE PR	Year	Code	Assessed	Year	Code	Assessed	Year	Co	Assessed			
0 0	10-533	1063 761	02-26-2010	Q	1,400,00	2018	400	2,111,500	2017	400	2,111,500	2016	400	2,111,500			
0 0			01-01-2010		0		400	272,800		400	272,800		400	272,800			
0 0								400	25,700		400	25,700		400	25,700		
Total								2410000			2410000			2410000			

EXEMPTIONS				OTHER ASSESSMENTS			
Year	Code	Description	Amount	Code	Description	Number	Amount
Total			0.00				

AG DISTRICT			
<b>APPRAISED VALUE SUMMARY</b>			
Appraised Bldg. Value (Card)			2,111,500
Appraised XF (B) Value (Bldg)			0
Appraised OB (B) Value (Bldg)			25,700
Appraised Land Value			272,800
Special Land Value			0
Total Appraised Parcel Value			2,410,000
Valuation Method			C
Exemption			0
Adjustment			
Total Appraised Parcel Value			2,410,000

ASSESSING NEIGHBORHOOD				
NBHD	NBHD Name	Street Index Name	District Code	Class Code
0001			T17	04

NOTES						

LAND LINE VALUATION SECTION																				
B	Use co	Description	Zone	D	Land	Land Type	Units	Unit Price	I. Fact	S.A.	Ac Di	C. Fact	St. Idx	Adj	Notes	Special Pricing	Size	Adj Unit Pric	Land Value	
5	400R	Comm - Incl -					0.000 AC	1.00	1.000	5		1.00		1.00			0	1.000	1.00	0
Total Card Land Units							0.000 AC	Parcel Total Land Area		8.0000								Total Land Value	0	

CONSTRUCTION DETAIL			CONSTRUCTION DETAIL (CONTINUED)		
Element	Cd	Description	Element	Cd	Description
Model	01	Residential	Chimney - 1P		
Building Class	30	COMMERCIAL	Chimney - 2M		
Style	006	WALKUP APARTMENT	Chimney - 2P		
Grade	24	C			
Foundation Ty	CB	Concrete Block			
Exterior Wall 1	02	Brick Veneer			
Exterior Wall 2	01	Wood Lap Siding			
Roof Structure	01	Gable			
Roof Cover 1	01	Composition Shingle			
Roof Cover 2					
Interior Wall 1	01	Dry Wall			
Interior Wall 2					
Interior Floor 1	01	Carpet			
Interior Floor 2	02	Vinyl			
Interior Floor 3					
Fuel Type 1	E	Electric			
Fuel Type 2					
Heat Type 1	01	Central Heat			
Heat Type 2					
AC Type	02	Central Air			
Total Rooms	4				
Bedrooms	0				
Full Bath(s)	8				
Full Bath Grad	C				
Half Bath(s)	0				
Half Bath Grad					
Extra Fixture(s)		Average Quality Constructi			
Extra Fix Grad					
Fireplace Ope	0				
Fireplace(s)					
Chimney - 1M					
Chimnev - 1P					

MIXED USE		
Code	Description	Percentage
400R	Comm - Indl - Res	100
		0
		0

COST / MARKET VALUATION		
Base Rate		45.18
RCN		135,510
Net Other Adj		26,402
RCN		135,510
AYB		1975
Effective Year Built		
Depreciation Code	A	
Remodel Rating		
Year Remodeled		
EYB DPR	20	
Functional Obsol	0	
Economic Obsol		
Cost Trend Factor	1	
Condition		
% Complete	80	
RCNLD	0	
Dep % Ovr		
Dep Ovr Comment		
Misc Imp Ovr		
Misc Imp Ovr Comment		
Cost to Cure Ovr		
Cost to Cure Ovr Comment		

OB - OUTBUILDING & YARD ITEMS(L) / XF - BUILDING EXTRA FEATURES(B)											
Code	Description	Su	Sub Desc	Lan	Units	Unit Price	Year	%	Cond	#	Apprais Valu

BUILDING SUB-AREA SUMMARY SECTION						
SUBAR	Description	LIVING	GROSS	EFF AR		
APT	Apartment	3,780	3,780	2,079		
STG	Storage	0	192	31		
Ttl Gross Liv / Lease Area		3,780	3,972	2,110		

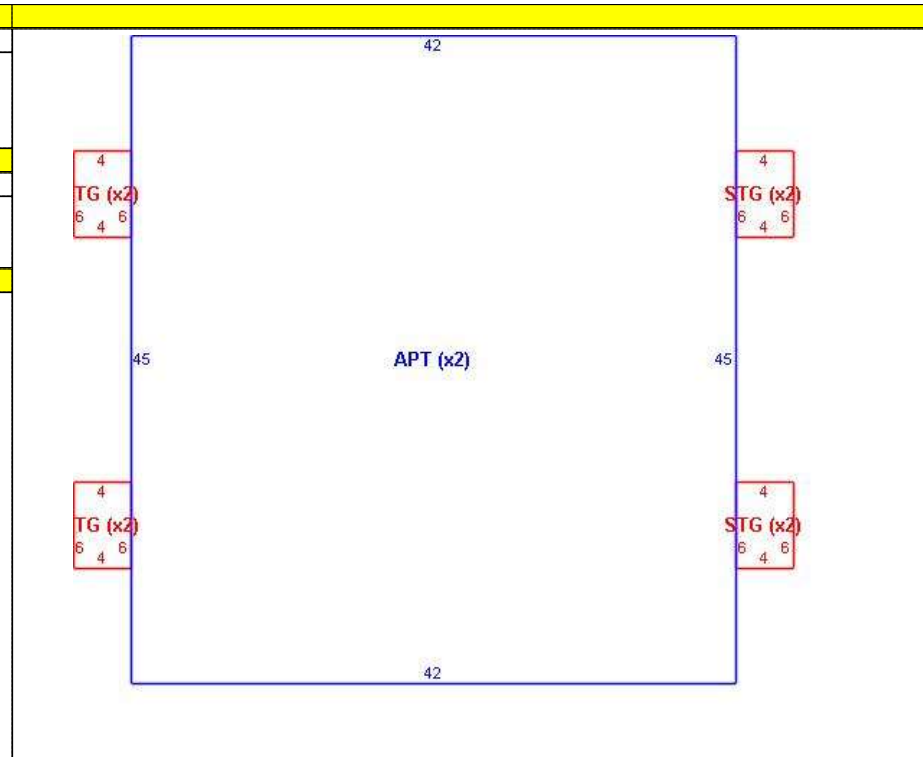

CURRENT OWNER			TOPO	UTILITIES	STRT / ROAD	ZONING	CURRENT ASSESSMENT				
NEW WESTSIDE VILLAGE I LIMITED PARTNERSHIP % T M ASS. MGMT INC 1375 PICCARD DR STE 150  ROCKVILLE MD 20850			0 Unknown	0 All Public Utiliti	0 Paved		Describe	Co	LU MRKT Value	Appraised	Assessed
			0 Level	0 Unknown			Building	400	0	2,111,500	2,111,500
			0 Unknown	0 Unknown			Land	400	0	272,800	272,800
<b>SUPPLEMENTAL DATA</b>							Outbldg	400	0	25,700	25,700
			Plat	Lister Date							
			NBHD Cod T17-8:South Boston - B	Mobile Ho 0							
			Info By E:Estimated Informatio								
			Exempt 00:No	Tracts 0							
			Total Acre 8	Road Num 654							
			Lister	Gis ID 059-01-00-0001							
Total									2,410,000	2,410,000	

Parcel Description WESTSIDE VILLAGE APTS. Total Appraised Land 272,800

RECORD OF OWNERSHIP							WILL BK/PG	INSTRUMENT	BK-VOL/PAGE	SALE DATE	Q/	SALE PR	PREVIOUS ASSESSMENTS (HISTORY)					
Year	Code	Assessed	Year	Code	Assessed	Year	Co	Assessed	Year	Co	Assessed							
2018	400	2,111,500	2017	400	2,111,500	2016	400	2,111,500	2016	400	2,111,500							
	400	272,800		400	272,800		400	272,800		400	272,800							
	400	25,700		400	25,700		400	25,700		400	25,700							
Total		2410000	Total		2410000	Total		2410000	Total		2410000							

EXEMPTIONS				OTHER ASSESSMENTS			
Year	Code	Description	Amount	Code	Description	Number	Amount
Total			0.00				

AG DISTRICT			
APPRAISED VALUE SUMMARY			
Appraised Bldg. Value (Card)		2,111,500	
Appraised XF (B) Value (Bldg)		0	
Appraised OB (B) Value (Bldg)		25,700	
Appraised Land Value		272,800	
Special Land Value		0	
Total Appraised Parcel Value		2,410,000	
Valuation Method		C	
Exemption		0	
Adjustment			
Total Appraised Parcel Value		2,410,000	

ASSESSING NEIGHBORHOOD				
NBHD	NBHD Name	Street Index Name	District Code	Class Code
0001			T17	04

NOTES						

LAND LINE VALUATION SECTION																				
B	Use co	Description	Zone	D	Land	Land Type	Units	Unit Price	I. Fact	S.A.	Ac Di	C. Fact	St. Idx	Adj	Notes	Special Pricing	Size	Adj Unit Pric	Land Value	
6	400R	Comm - Indl -					0.000	AC	1.00	1.000	5	1.00		1.00			0	1.000	1.00	0
Total Card Land Units							0.000	AC	Parcel Total Land Area			8.0000	Total Land Value							0

CONSTRUCTION DETAIL			CONSTRUCTION DETAIL (CONTINUED)		
Element	Cd	Description	Element	Cd	Description
Model	01	Residential	Chimney - 1P		
Building Class	30	COMMERCIAL	Chimney - 2M		
Style	006	WALKUP APARTMENT	Chimney - 2P		
Grade	24	C			
Foundation Ty	BR	Brick	<b>MIXED USE</b>		
Exterior Wall 1	02	Brick Veneer	Code	Description	Percentage
Exterior Wall 2	01	Wood Lap Siding	400R	Comm - Indl - Res	100
Roof Structure	01	Gable			0
Roof Cover 1	01	Composition Shingle			0
Roof Cover 2			<b>COST / MARKET VALUATION</b>		
Interior Wall 1	01	Dry Wall	Base Rate	45.18	
Interior Wall 2			RCN	135,510	
Interior Floor 1	01	Carpet	Net Other Adj	26,402	
Interior Floor 2	02	Vinyl	RCN	135,510	
Interior Floor 3			AYB	1975	
Fuel Type 1	E	Electric	Effective Year Built		
Fuel Type 2			Depreciation Code	A	
Heat Type 1	01	Central Heat	Remodel Rating		
Heat Type 2			Year Remodeled		
AC Type	02	Central Air	EYB DPR	20	
Total Rooms	4		Functional Obsol	0	
Bedrooms	0		Economic Obsol		
Full Bath(s)	8		Cost Trend Factor	1	
Full Bath Grad	C		Condition		
Half Bath(s)	0		% Complete	80	
Half Bath Grad			RCNLD	0	
Extra Fixture(s)		Average Quality Constructi	Dep % Ovr		
Extra Fix Grad			Dep Ovr Comment		
Fireplace Ope	0		Misc Imp Ovr		
Fireplace(s)			Misc Imp Ovr Comment		
Chimney - 1M			Cost to Cure Ovr		
Chimnev - 1P			Cost to Cure Ovr Comment		

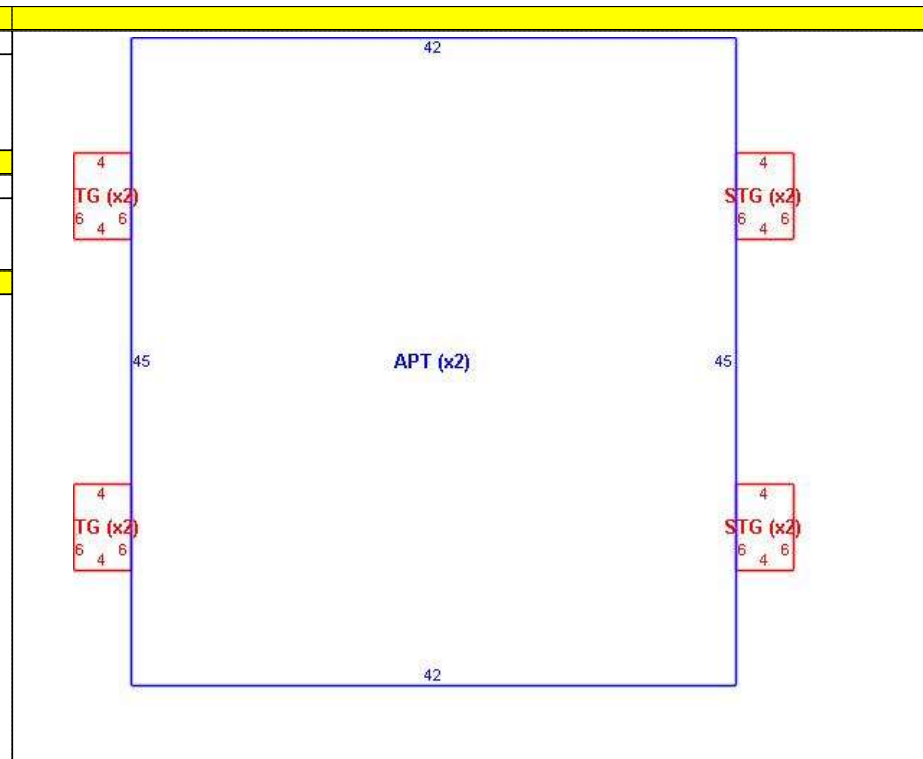

OB - OUTBUILDING & YARD ITEMS(L) / XF - BUILDING EXTRA FEATURES(B)											
Code	Description	Su	Sub Desc	Lan	Units	Unit Price	Year	%	Cond	#	Apprais Valu

BUILDING SUB-AREA SUMMARY SECTION						
SUBAR	Description	LIVING	GROSS	EFF AR		
APT	Apartment	3,780	3,780	2,079		
STG	Storage	0	192	31		
Ttl Gross Liv / Lease Area		3,780	3,972	2,110		

CURRENT OWNER			TOPO	UTILITIES	STRT / ROAD	ZONING	CURRENT ASSESSMENT				
NEW WESTSIDE VILLAGE I LIMITED PARTNERSHIP % T M ASS. MGMT INC 1375 PICCARD DR STE 150  ROCKVILLE MD 20850			0 Unknown	0 All Public Utiliti	0 Paved		Describe	Co	LU MRKT Value	Appraised	Assessed
			0 Level	0 Unknown			Building	400	0	2,111,500	2,111,500
			0 Unknown	0 Unknown			Land	400	0	272,800	272,800
<b>SUPPLEMENTAL DATA</b>							Outbldg	400	0	25,700	25,700
			Plat	Lister Date							
			NBHD Cod T17-8:South Boston - B	Mobile Ho 0							
			Info By E:Estimated Informatio								
			Exempt 00:No	Tracts 0							
			Total Acre 8	Road Num 654							
			Lister	Gis ID 059-01-00-0001							
							Total			2,410,000	2,410,000

Parcel Description WESTSIDE VILLAGE APTS. Total Appraised Land 272,800

RECORD OF OWNERSHIP							WILL BK/PG	INSTRUMENT	BK-VOL/PAGE	SALE DATE	Q/	SALE PR	PREVIOUS ASSESSMENTS (HISTORY)					
Year	Code	Assessed	Year	Code	Assessed	Year	Co	Assessed	Year	Co	Assessed							
2018	400	2,111,500	2017	400	2,111,500	2016	400	2,111,500	2016	400	2,111,500							
	400	272,800		400	272,800		400	272,800		400	272,800							
	400	25,700		400	25,700		400	25,700		400	25,700							
Total		2410000	Total		2410000	Total		2410000	Total		2410000							

EXEMPTIONS				OTHER ASSESSMENTS			
Year	Code	Description	Amount	Code	Description	Number	Amount
			0.00				
Total			0.00				

AG DISTRICT			
APPRAISED VALUE SUMMARY			
Appraised Bldg. Value (Card)			2,111,500
Appraised XF (B) Value (Bldg)			0
Appraised OB (B) Value (Bldg)			25,700
Appraised Land Value			272,800
Special Land Value			0
Total Appraised Parcel Value			2,410,000
Valuation Method			C
Exemption			0
Adjustment			
Total Appraised Parcel Value			2,410,000

ASSESSING NEIGHBORHOOD				
NBHD	NBHD Name	Street Index Name	District Code	Class Code
0001			T17	04

NOTES						

LAND LINE VALUATION SECTION																				
B	Use co	Description	Zone	D	Land	Land Type	Units	Unit Price	I. Fact	S.A.	Ac Di	C. Fact	St. Idx	Adj	Notes	Special Pricing	Size	Adj Unit Pric	Land Value	
7	400R	Comm - Incl -					0.000	AC	1.00	1.000	5	1.00		1.00			0	1.000	1.00	0
Total Card Land Units							0.000	AC	Parcel Total Land Area			8.0000	Total Land Value							0



CONSTRUCTION DETAIL			CONSTRUCTION DETAIL (CONTINUED)		
Element	Cd	Description	Element	Cd	Description
Model	01	Residential	Chimney - 1P		
Building Class	30	COMMERCIAL	Chimney - 2M		
Style	006	WALKUP APARTMENT	Chimney - 2P		
Grade	24	C			
Foundation Ty	BR	Brick	<b>MIXED USE</b>		
Exterior Wall 1	02	Brick Veneer	Code	Description	Percentage
Exterior Wall 2	01	Wood Lap Siding	400R	Comm - Indl - Res	100
Roof Structure	01	Gable			0
Roof Cover 1	01	Composition Shingle			0
Roof Cover 2			<b>COST / MARKET VALUATION</b>		
Interior Wall 1	01	Dry Wall	Base Rate	45.18	
Interior Wall 2			RCN	135,510	
Interior Floor 1	01	Carpet	Net Other Adj	26,402	
Interior Floor 2	02	Vinyl	RCN	135,510	
Interior Floor 3			AYB	1975	
Fuel Type 1	E	Electric	Effective Year Built		
Fuel Type 2			Depreciation Code	A	
Heat Type 1	01	Central Heat	Remodel Rating		
Heat Type 2			Year Remodeled		
AC Type	02	Central Air	EYB DPR	20	
Total Rooms	4		Functional Obsol	0	
Bedrooms	0		Economic Obsol		
Full Bath(s)	8		Cost Trend Factor	1	
Full Bath Grad	C		Condition		
Half Bath(s)	0		% Complete	80	
Half Bath Grad			RCNLD	0	
Extra Fixture(s)		Average Quality Constructi	Dep % Ovr		
Extra Fix Grad			Dep Ovr Comment		
Fireplace Ope	0		Misc Imp Ovr		
Fireplace(s)			Misc Imp Ovr Comment		
Chimney - 1M			Cost to Cure Ovr		
Chimnev - 1P			Cost to Cure Ovr Comment		

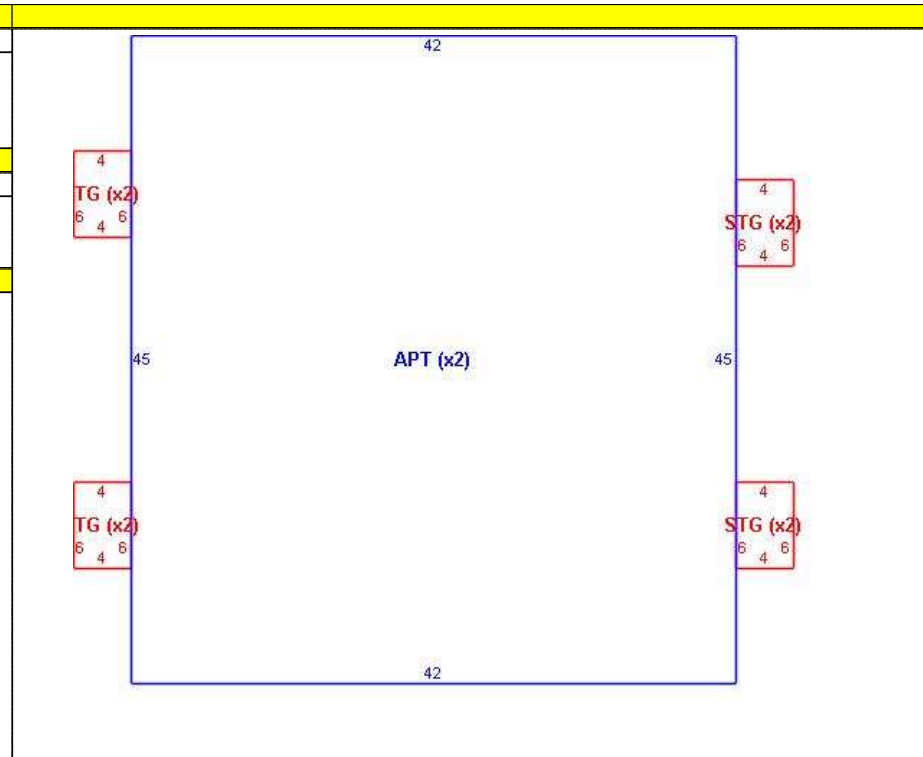

OB - OUTBUILDING & YARD ITEMS(L) / XF - BUILDING EXTRA FEATURES(B)											
Code	Description	Su	Sub Desc	Lan	Units	Unit Price	Year	%	Cond	#	Apprais Valu

BUILDING SUB-AREA SUMMARY SECTION						
SUBAR	Description	LIVING	GROSS	EFF AR		
APT	Apartment	3,780	3,780	2,079		
STG	Storage	0	192	31		
Ttl Gross Liv / Lease Area		3,780	3,972	2,110		

CURRENT OWNER			TOPO	UTILITIES	STRT / ROAD	ZONING	CURRENT ASSESSMENT				
NEW WESTSIDE VILLAGE I LIMITED PARTNERSHIP % T M ASS. MGMT INC 1375 PICCARD DR STE 150  ROCKVILLE MD 20850			0 Unknown	0 All Public Utiliti	0 Paved		Describe	Co	LU MRKT Value	Appraised	Assessed
			0 Level	0 Unknown			Building	400	0	2,111,500	2,111,500
			0 Unknown	0 Unknown			Land	400	0	272,800	272,800
<b>SUPPLEMENTAL DATA</b>							Outbldg	400	0	25,700	25,700
Plat			NBHD Cod T17-8:South Boston - B			Lister Date					
Info By			E:Estimated Informatio			Mobile Ho 0					
Exempt 00:No			Tracts 0			Road Num 654					
Total Acre 8			Road Num 654			Gis ID 059-01-00-0001					
Lister											
							Total		2,410,000		2,410,000

Parcel Description WESTSIDE VILLAGE APTS. Total Appraised Land 272,800

RECORD OF OWNERSHIP							WILL BK/PG	INSTRUMENT	BK-VOL/PAGE	SALE DATE	Q/	SALE PR	PREVIOUS ASSESSMENTS (HISTORY)								
NEW WESTSIDE VILLAGE I LIMITED							0 0	10-533	1063 761	02-26-2010	Q	1,400,00	Year	Code	Assessed	Year	Code	Assessed	Year	Co	Assessed
WESTSIDE VILLAGE ASSOCIATES							0 0		0 0	01-01-2010		0	2018	400	2,111,500	2017	400	2,111,500	2016	400	2,111,500
							0 0						400	272,800		400	272,800		400	272,800	
							0 0						400	25,700		400	25,700		400	25,700	
													Total	2410000		Total	2410000		Total	2410000	

EXEMPTIONS				OTHER ASSESSMENTS			
Year	Code	Description	Amount	Code	Description	Number	Amount
Total			0.00				

AG DISTRICT			
<b>APPRAISED VALUE SUMMARY</b>			
Appraised Bldg. Value (Card)			2,111,500
Appraised XF (B) Value (Bldg)			0
Appraised OB (B) Value (Bldg)			25,700
Appraised Land Value			272,800
Special Land Value			0
Total Appraised Parcel Value			2,410,000
Valuation Method			C
Exemption			0
Adjustment			
Total Appraised Parcel Value			2,410,000

ASSESSING NEIGHBORHOOD					
NBHD	NBHD Name	Street Index Name	District Code	Class Code	
0001			T17	04	

NOTES						

VISIT / CHANGE HISTORY																		
Date	Type	IS	ID	Cd	Purpose/Result	Notes												

LAND LINE VALUATION SECTION																					
B	Use co	Description	Zone	D	Land	Land Type	Units	Unit Price	I. Fact	S.A.	Ac Di	C. Fact	St. Idx	Adj	Notes	Special Pricing	Size	Adj Unit Pric	Land Value		
8	400R	Comm - Incl -					0.000	AC	1.00	1.000	5	1.00		1.00			0	1.000	1.00	0	
Total Card Land Units							0.000	AC	Parcel Total Land Area			8.0000								Total Land Value	0

CONSTRUCTION DETAIL			CONSTRUCTION DETAIL (CONTINUED)		
Element	Cd	Description	Element	Cd	Description
Model	01	Residential	Chimney - 1P		
Building Class	30	COMMERCIAL	Chimney - 2M		
Style	006	WALKUP APARTMENT	Chimney - 2P		
Grade	24	C			
Foundation Ty	BR	Brick			
Exterior Wall 1	02	Brick Veneer			
Exterior Wall 2	01	Wood Lap Siding			
Roof Structure	01	Gable			
Roof Cover 1	01	Composition Shingle			
Roof Cover 2					
Interior Wall 1	01	Dry Wall			
Interior Wall 2					
Interior Floor 1	01	Carpet			
Interior Floor 2	02	Vinyl			
Interior Floor 3					
Fuel Type 1	E	Electric			
Fuel Type 2					
Heat Type 1	01	Central Heat			
Heat Type 2					
AC Type	02	Central Air			
Total Rooms	4				
Bedrooms	0				
Full Bath(s)	8				
Full Bath Grad	C				
Half Bath(s)	0				
Half Bath Grad					
Extra Fixture(s)		Average Quality Constructi			
Extra Fix Grad					
Fireplace Ope	0				
Fireplace(s)					
Chimney - 1M					
Chimnev - 1P					

MIXED USE		
Code	Description	Percentage
400R	Comm - Indl - Res	100
		0
		0

COST / MARKET VALUATION		
Base Rate		45.18
RCN		135,510
Net Other Adj		26,402
RCN		135,510
AYB		1975
Effective Year Built		
Depreciation Code	A	
Remodel Rating		
Year Remodeled		
EYB DPR	20	
Functional Obsol	0	
Economic Obsol		
Cost Trend Factor	1	
Condition		
% Complete	80	
RCNLD	0	
Dep % Ovr		
Dep Ovr Comment		
Misc Imp Ovr		
Misc Imp Ovr Comment		
Cost to Cure Ovr		
Cost to Cure Ovr Comment		

OB - OUTBUILDING & YARD ITEMS(L) / XF - BUILDING EXTRA FEATURES(B)											
Code	Description	Su	Sub Desc	Lan	Units	Unit Price	Year	%	Cond	#	Apprais Valu

BUILDING SUB-AREA SUMMARY SECTION						
SUBAR	Description	LIVING	GROSS	EFF AR		
APT	Apartment	3,780	3,780	2,079		
STG	Storage	0	192	31		
Ttl Gross Liv / Lease Area		3,780	3,972	2,110		

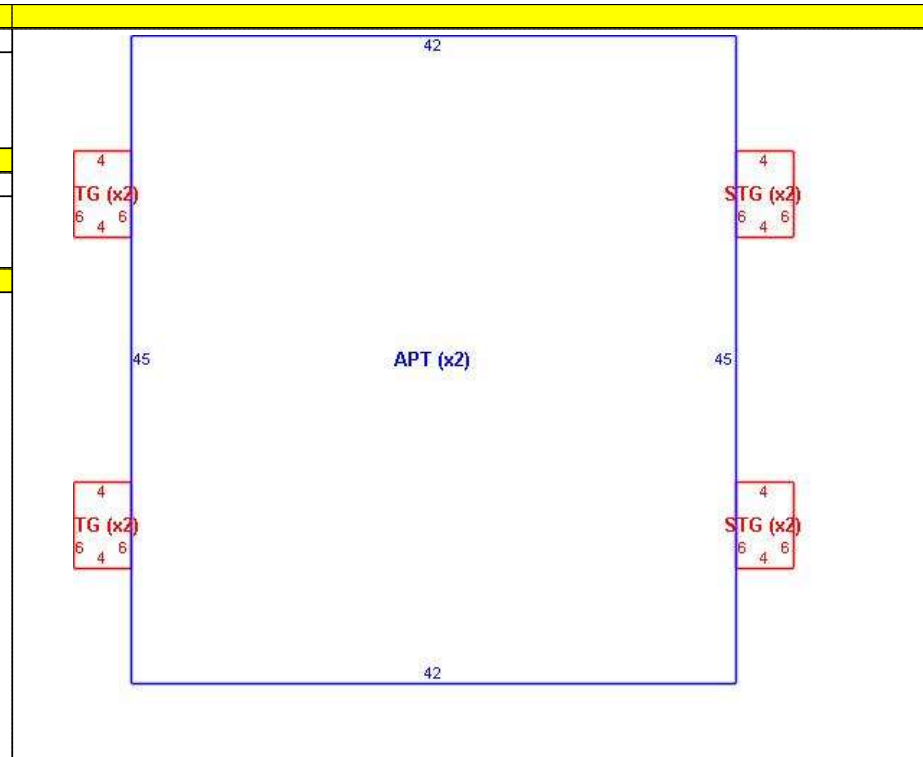

--	--	--	--	--	--	--

CURRENT OWNER			TOPO	UTILITIES	STRT / ROAD	ZONING	CURRENT ASSESSMENT				
NEW WESTSIDE VILLAGE I LIMITED PARTNERSHIP % T M ASS. MGMT INC 1375 PICCARD DR STE 150  ROCKVILLE MD 20850			0 Unknown	0 All Public Utiliti	0 Paved		Describe	Co	LU MRKT Value	Appraised	Assessed
			0 Level	0 Unknown			Building	400	0	2,111,500	2,111,500
			0 Unknown	0 Unknown			Land	400	0	272,800	272,800
<b>SUPPLEMENTAL DATA</b>							Outldg	400	0	25,700	25,700
			Plat	Lister Date							
			NBHD Cod T17-8:South Boston - B	Mobile Ho 0							
			Info By E:Estimated Informatio								
			Exempt 00:No	Tracts 0							
			Total Acre 8	Road Num 654							
			Lister	Gis ID 059-01-00-0001							
Total									2,410,000	2,410,000	

Parcel Description WESTSIDE VILLAGE APTS. Total Appraised Land 272,800

RECORD OF OWNERSHIP							WILL BK/PG	INSTRUMENT	BK-VOL/PAGE	SALE DATE	Q/	SALE PR	PREVIOUS ASSESSMENTS (HISTORY)								
NEW WESTSIDE VILLAGE I LIMITED							0 0	10-533	1063 761	02-26-2010	Q	1,400,00	Year	Code	Assessed	Year	Code	Assessed	Year	Co	Assessed
WESTSIDE VILLAGE ASSOCIATES							0 0		0 0	01-01-2010		0	2018	400	2,111,500	2017	400	2,111,500	2016	400	2,111,500
							0 0							400	272,800		400	272,800		400	272,800
							0 0							400	25,700		400	25,700		400	25,700
Total													Total	2410000	Total	2410000	Total	2410000	Total	2410000	

EXEMPTIONS				OTHER ASSESSMENTS			
Year	Code	Description	Amount	Code	Description	Number	Amount
Total			0.00				

AG DISTRICT			
<b>APPRAISED VALUE SUMMARY</b>			
Appraised Bldg. Value (Card)			2,111,500
Appraised XF (B) Value (Bldg)			0
Appraised OB (B) Value (Bldg)			25,700
Appraised Land Value			272,800
Special Land Value			0
Total Appraised Parcel Value			2,410,000
Valuation Method			C
Exemption			0
Adjustment			
Total Appraised Parcel Value			2,410,000

ASSESSING NEIGHBORHOOD				
NBHD	NBHD Name	Street Index Name	District Code	Class Code
0001			T17	04

NOTES						

VISIT / CHANGE HISTORY										
Date	Type	IS	ID	Cd	Purpose/Result	Notes				

LAND LINE VALUATION SECTION																				
B	Use co	Description	Zone	D	Land	Land Type	Units	Unit Price	I. Fact	S.A.	Ac Di	C. Fact	St. Idx	Adj	Notes	Special Pricing	Size	Adj Unit Pric	Land Value	
9	400R	Comm - Incl -					0.000 AC	1.00	1.000	5		1.00		1.00			0	1.000	1.00	0
Total Card Land Units							0.000 AC	Parcel Total Land Area			8.0000	Total Land Value							0	

**CONSTRUCTION DETAIL** **CONSTRUCTION DETAIL (CONTINUED)**

Element	Cd	Description	Element	Cd	Description
Model	01	Residential	Chimney - 1P		
Building Class	30	COMMERCIAL	Chimney - 2M		
Style	006	WALKUP APARTMENT	Chimney - 2P		
Grade	24	C			
Foundation Ty	BR	Brick	<b>MIXED USE</b>		
Exterior Wall 1	02	Brick Veneer	Code	Description	Percentage
Exterior Wall 2	01	Wood Lap Siding	400R	Comm - Incl - Res	100
Roof Structure	01	Gable			0
Roof Cover 1	01	Composition Shingle			0
Roof Cover 2			<b>COST / MARKET VALUATION</b>		
Interior Wall 1	01	Dry Wall	Base Rate		45.18
Interior Wall 2			RCN		166,369
Interior Floor 1	01	Carpet	Net Other Adj		29,831
Interior Floor 2	02	Vinyl	RCN		166,369
Interior Floor 3			AYB		1975
Fuel Type 1	E	Electric	Effective Year Built		
Fuel Type 2			Depreciation Code	A	
Heat Type 1	01	Central Heat	Remodel Rating		
Heat Type 2			Year Remodeled		
AC Type	02	Central Air	EYB DPR	20	
Total Rooms	32		Functional Obsol	0	
Bedrooms	0		Economic Obsol		
Full Bath(s)	8		Cost Trend Factor	1	
Full Bath Grad	C		Condition		
Half Bath(s)	0		% Complete	80	
Half Bath Grad			RCNLD	0	
Extra Fixture(s)		Average Quality Constructi	Dep % Ovr		
Extra Fix Grad			Dep Ovr Comment		
Fireplace Ope	0		Misc Imp Ovr		
Fireplace(s)			Misc Imp Ovr Comment		
Chimney - 1M			Cost to Cure Ovr		
Chimnev - 1P			Cost to Cure Ovr Comment		

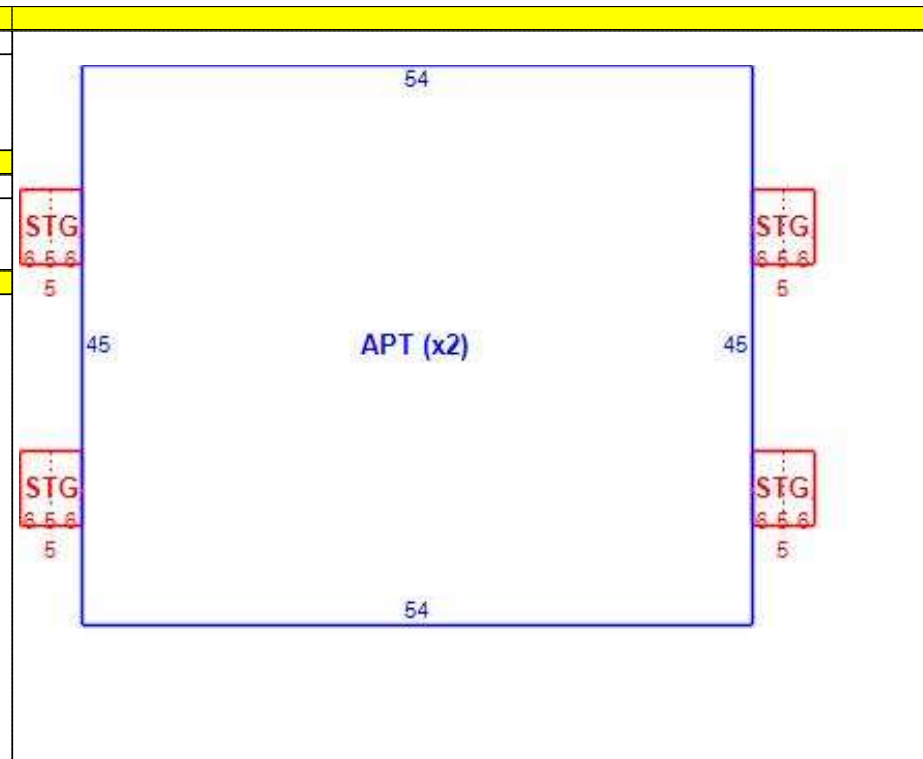

**OB - OUTBUILDING & YARD ITEMS(L) / XF - BUILDING EXTRA FEATURES(B)**

Code	Description	Su	Sub Desc	Lan	Units	Unit Price	Year	%	Cond	#	Apprais Valu

**BUILDING SUB-AREA SUMMARY SECTION**

SUBAR	Description	LIVING	GROSS	EFF AR
APT	Apartment	4,860	4,860	2,673
STG	Storage	0	120	19
Ttl Gross Liv / Lease Area		4,860	4,980	2,692

CURRENT OWNER			TOPO	UTILITIES	STRT / ROAD	ZONING	CURRENT ASSESSMENT				
NEW WESTSIDE VILLAGE I LIMITED PARTNERSHIP % T M ASS. MGMT INC 1375 PICCARD DR STE 150  ROCKVILLE MD 20850			0 Unknown	0 All Public Utiliti	0 Paved		Describe	Co	LU MRKT Value	Appraised	Assessed
			0 Level	0 Unknown			Building	400	0	2,111,500	2,111,500
			0 Unknown	0 Unknown			Land	400	0	272,800	272,800
<b>SUPPLEMENTAL DATA</b>							Outbldg	400	0	25,700	25,700
			Plat	Lister Date							
			NBHD Cod T17-8:South Boston - B	Mobile Ho 0							
			Info By E:Estimated Informatio								
			Exempt 00:No	Tracts 0							
			Total Acre 8	Road Num 654							
			Lister	Gis ID 059-01-00-0001							
							Total			2,410,000	2,410,000

Parcel Description WESTSIDE VILLAGE APTS. Total Appraised Land 272,800

RECORD OF OWNERSHIP							WILL BK/PG	INSTRUMENT	BK-VOL/PAGE	SALE DATE	Q/	SALE PR	PREVIOUS ASSESSMENTS (HISTORY)					
Year	Code	Assessed	Year	Code	Assessed	Year	Co	Assessed	Year	Co	Assessed							
2018	400	2,111,500	2017	400	2,111,500	2016	400	2,111,500	2016	400	2,111,500							
	400	272,800		400	272,800		400	272,800		400	272,800							
	400	25,700		400	25,700		400	25,700		400	25,700							
Total		2410000	Total		2410000	Total		2410000	Total		2410000							

EXEMPTIONS				OTHER ASSESSMENTS			
Year	Code	Description	Amount	Code	Description	Number	Amount
Total			0.00				

AG DISTRICT			
APPRAISED VALUE SUMMARY			
Appraised Bldg. Value (Card)		2,111,500	
Appraised XF (B) Value (Bldg)		0	
Appraised OB (B) Value (Bldg)		25,700	
Appraised Land Value		272,800	
Special Land Value		0	
Total Appraised Parcel Value		2,410,000	
Valuation Method		C	
Exemption		0	
Adjustment			
Total Appraised Parcel Value		2,410,000	

ASSESSING NEIGHBORHOOD				
NBHD	NBHD Name	Street Index Name	District Code	Class Code
0001			T17	04

NOTES						

VISIT / CHANGE HISTORY																		
Date	Type	IS	ID	Cd	Purpose/Result	Notes												

LAND LINE VALUATION SECTION																					
B	Use co	Description	Zone	D	Land	Land Type	Units	Unit Price	I. Fact	S.A.	Ac Di	C. Fact	St. Idx	Adj	Notes	Special Pricing	Size	Adj Unit Pric	Land Value		
10	400R	Comm - Incl -					0.000	AC	1.00	1.000	5	1.00		1.00			0	1.000	1.00	0	
Total Card Land Units							0.000	AC	Parcel Total Land Area			8.0000								Total Land Value	0

CONSTRUCTION DETAIL			CONSTRUCTION DETAIL (CONTINUED)		
Element	Cd	Description	Element	Cd	Description
Model	01	Residential	Chimney - 1P		
Building Class	30	COMMERCIAL	Chimney - 2M		
Style	006	WALKUP APARTMENT	Chimney - 2P		
Grade	24	C			
Foundation Ty	BR	Brick	<b>MIXED USE</b>		
Exterior Wall 1	02	Brick Veneer	Code	Description	Percentage
Exterior Wall 2	01	Wood Lap Siding	400R	Comm - Indl - Res	100
Roof Structure	01	Gable			0
Roof Cover 1	01	Composition Shingle			0
Roof Cover 2			<b>COST / MARKET VALUATION</b>		
Interior Wall 1	01	Dry Wall	Base Rate		45.18
Interior Wall 2			RCN		175,622
Interior Floor 1	01	Carpet	Net Other Adj		30,859
Interior Floor 2	02	Vinyl	RCN		175,622
Interior Floor 3			AYB		1975
Fuel Type 1	E	Electric	Effective Year Built		
Fuel Type 2			Depreciation Code	A	
Heat Type 1	01	Central Heat	Remodel Rating		
Heat Type 2			Year Remodeled		
AC Type	02	Central Air	EYB DPR	20	
Total Rooms	32		Functional Obsol	0	
Bedrooms	0		Economic Obsol		
Full Bath(s)	8		Cost Trend Factor	1	
Full Bath Grad	C		Condition		
Half Bath(s)	0		% Complete	80	
Half Bath Grad			RCNLD	0	
Extra Fixture(s)		Average Quality Constructi	Dep % Ovr		
Extra Fix Grad			Dep Ovr Comment		
Fireplace Ope	0		Misc Imp Ovr		
Fireplace(s)			Misc Imp Ovr Comment		
Chimney - 1M			Cost to Cure Ovr		
Chimnev - 1P			Cost to Cure Ovr Comment		

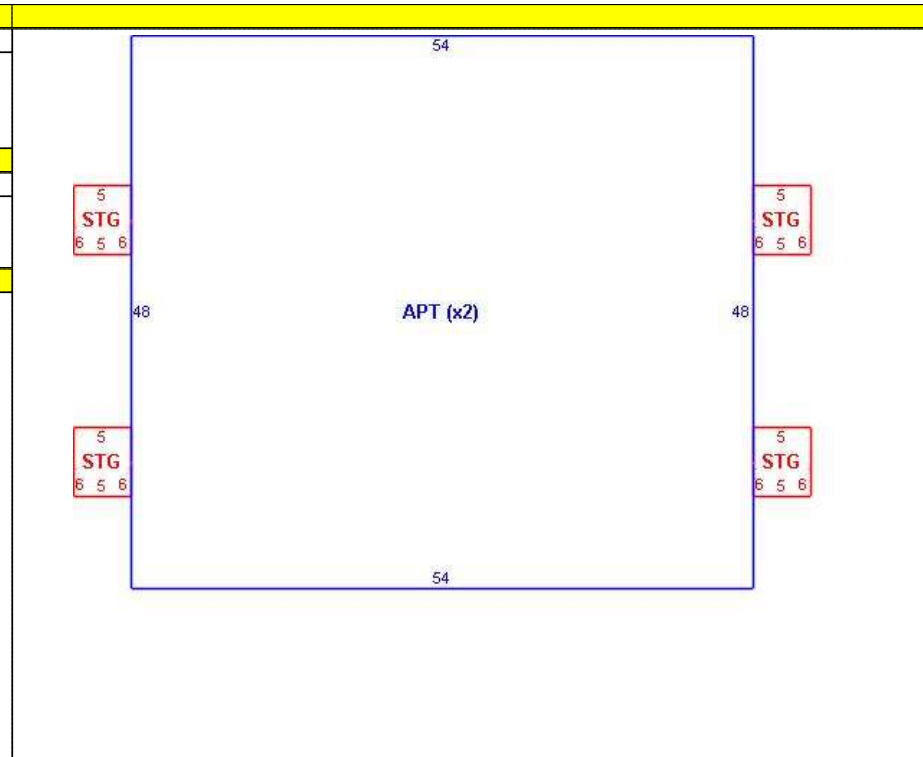

OB - OUTBUILDING & YARD ITEMS(L) / XF - BUILDING EXTRA FEATURES(B)											
Code	Description	Su	Sub Desc	Lan	Units	Unit Price	Year	%	Cond	#	Apprais Valu

BUILDING SUB-AREA SUMMARY SECTION						
SUBAR	Description	LIVING	GROSS	EFF AR		
APT	Apartment	5,184	5,184	2,851		
STG	Storage	0	120	19		
Ttl Gross Liv / Lease Area		5,184	5,304	2,870		

CURRENT OWNER			TOPO	UTILITIES	STRT / ROAD	ZONING	CURRENT ASSESSMENT				
NEW WESTSIDE VILLAGE I LIMITED PARTNERSHIP % T M ASS. MGMT INC 1375 PICCARD DR STE 150			0 Unknown	0 All Public Utiliti	0 Paved		Describe	Co	LU MRKT Value	Appraised	Assessed
			0 Level	0 Unknown			Building	400	0	2,111,500	2,111,500
			0 Unknown	0 Unknown			Land	400	0	272,800	272,800
			<b>SUPPLEMENTAL DATA</b>			Outbldg	400	0	25,700	25,700	
ROCKVILLE MD 20850			Plat	NBHD Cod T17-8:South Boston - B	Lister Date						
			Info By	E:Estimated Informatio	Mobile Ho 0						
			Exempt	00:No	Tracts 0						
			Total Acre	8	Road Num 654						
			Lister		Gis ID 059-01-00-0001						
Parcel Description WESTSIDE VILLAGE APTS.							Total		2,410,000	2,410,000	2,410,000
							Total Appraised Land			272,800	272,800

RECORD OF OWNERSHIP							WILL BK/PG	INSTRUMENT	BK-VOL/PAGE	SALE DATE	Q/	SALE PR	PREVIOUS ASSESSMENTS (HISTORY)								
NEW WESTSIDE VILLAGE I LIMITED							0 0	10-533	1063 761	02-26-2010	Q	1,400,00	Year	Code	Assessed	Year	Code	Assessed	Year	Co	Assessed
WESTSIDE VILLAGE ASSOCIATES							0 0		0 0	01-01-2010		0	2018	400	2,111,500	2017	400	2,111,500	2016	400	2,111,500
							0 0							400	272,800		400	272,800		400	272,800
							0 0							400	25,700		400	25,700		400	25,700
												Total	2410000	Total	2410000	Total	2410000	Total	2410000		

EXEMPTIONS				OTHER ASSESSMENTS				AG DISTRICT				
Year	Code	Description	Amount	Code	Description	Number	Amount	Comm Int				
Total			0.00									

ASSESSING NEIGHBORHOOD					
NBHD	NBHD Name	Street Index Name	District Code	Class Code	
0001			T17	04	

NOTES										APPRAISED VALUE SUMMARY		
										Appraised Bldg. Value (Card)		2,111,500
										Appraised XF (B) Value (Bldg)		0
										Appraised OB (B) Value (Bldg)		25,700
										Appraised Land Value		272,800
										Special Land Value		0
										Total Appraised Parcel Value		2,410,000
										Valuation Method		C
Exemption		0										
Adjustment												
Total Appraised Parcel Value		2,410,000										

VISIT / CHANGE HISTORY									
Date	Type	IS	ID	Cd	Purpose/Result	Notes			

LAND LINE VALUATION SECTION																					
B	Use co	Description	Zone	D	Land	Land Type	Units	Unit Price	I. Fact	S.A.	Ac Di	C. Fact	St. Idx	Adj	Notes	Special Pricing	Size	Adj Unit Pric	Land Value		
11	400R	Comm - Incl -					0.000	AC	1.00	1.000	5	1.00		1.00			0	1.000	1.00	0	
Total Card Land Units							0.000	AC	Parcel Total Land Area			8.0000								Total Land Value	0



CONSTRUCTION DETAIL			CONSTRUCTION DETAIL (CONTINUED)		
Element	Cd	Description	Element	Cd	Description
Model	01	Residential	Chimney - 1P		
Building Class	30	COMMERCIAL	Chimney - 2M		
Style	006	WALKUP APARTMENT	Chimney - 2P		
Grade	24	C			
Foundation Ty	BR	Brick			
Exterior Wall 1	02	Brick Veneer			
Exterior Wall 2	01	Wood Lap Siding			
Roof Structure	01	Gable			
Roof Cover 1	01	Composition Shingle			
Roof Cover 2					
Interior Wall 1	01	Dry Wall			
Interior Wall 2					
Interior Floor 1	01	Carpet			
Interior Floor 2	02	Vinyl			
Interior Floor 3					
Fuel Type 1	E	Electric			
Fuel Type 2					
Heat Type 1	01	Central Heat			
Heat Type 2					
AC Type	02	Central Air			
Total Rooms	32				
Bedrooms	0				
Full Bath(s)	8				
Full Bath Grad	C				
Half Bath(s)	0				
Half Bath Grad					
Extra Fixture(s)		Average Quality Constructi			
Extra Fix Grad					
Fireplace Ope	0				
Fireplace(s)					
Chimney - 1M					
Chimnev - 1P					

MIXED USE		
Code	Description	Percentage
400R	Comm - Indl - Res	100
		0
		0

COST / MARKET VALUATION		
Base Rate		45.18
RCN		166,369
Net Other Adj		29,831
RCN		166,369
AYB		1975
Effective Year Built		
Depreciation Code	A	
Remodel Rating		
Year Remodeled		
EYB DPR	20	
Functional Obsol	0	
Economic Obsol		
Cost Trend Factor	1	
Condition		
% Complete	80	
RCNLD	0	
Dep % Ovr		
Dep Ovr Comment		
Misc Imp Ovr		
Misc Imp Ovr Comment		
Cost to Cure Ovr		
Cost to Cure Ovr Comment		

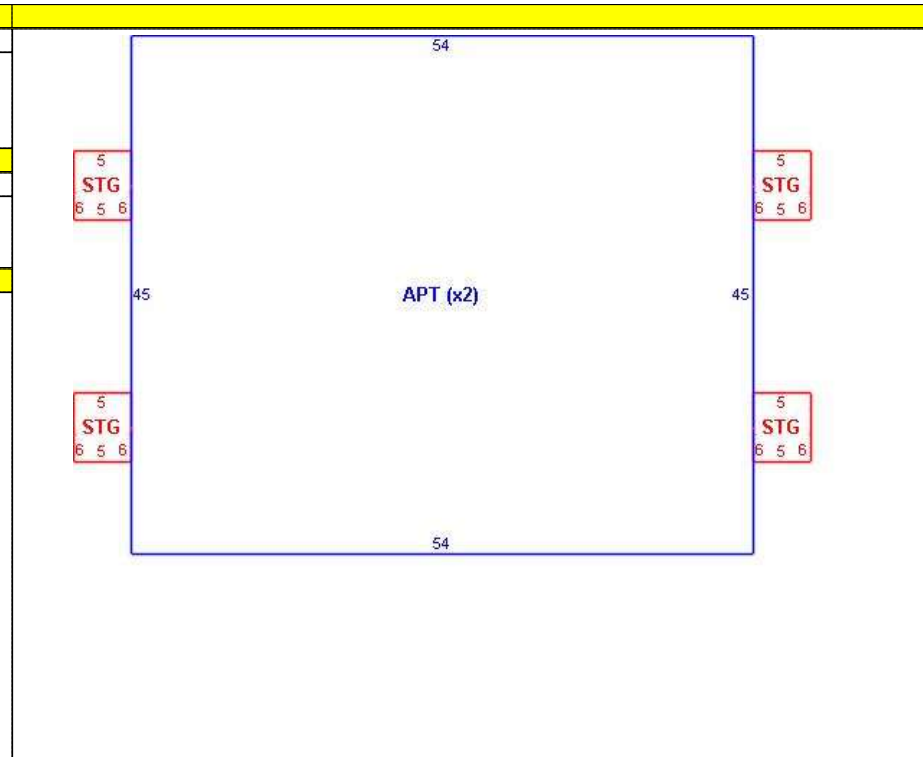

OB - OUTBUILDING & YARD ITEMS(L) / XF - BUILDING EXTRA FEATURES(B)											
Code	Description	Su	Sub Desc	Lan	Units	Unit Price	Year	%	Cond	#	Apprais Valu

BUILDING SUB-AREA SUMMARY SECTION						
SUBAR	Description	LIVING	GROSS	EFF AR		
APT	Apartment	4,860	4,860	2,673		
STG	Storage	0	120	19		
Ttl Gross Liv / Lease Area		4,860	4,980	2,692		

CURRENT OWNER			TOPO	UTILITIES	STRT / ROAD	ZONING	CURRENT ASSESSMENT				
NEW WESTSIDE VILLAGE I LIMITED PARTNERSHIP % T M ASS. MGMT INC 1375 PICCARD DR STE 150  ROCKVILLE MD 20850			0 Unknown	0 All Public Utiliti	0 Paved		Describe	Co	LU MRKT Value	Appraised	Assessed
			0 Level	0 Unknown			Building	400	0	2,111,500	2,111,500
			0 Unknown	0 Unknown			Land	400	0	272,800	272,800
<b>SUPPLEMENTAL DATA</b>							Outbldg	400	0	25,700	25,700
			Plat	Lister Date							
			NBHD Cod T17-8:South Boston - B	Mobile Ho 0							
			Info By E:Estimated Informatio								
			Exempt 00:No	Tracts 0							
			Total Acre 8	Road Num 654							
			Lister	Gis ID 059-01-00-0001							
							Total			2,410,000	2,410,000

Parcel Description WESTSIDE VILLAGE APTS. Total Appraised Land 272,800

RECORD OF OWNERSHIP							WILL BK/PG	INSTRUMENT	BK-VOL/PAGE	SALE DATE	Q/	SALE PR	PREVIOUS ASSESSMENTS (HISTORY)					
Year	Code	Assessed	Year	Code	Assessed	Year	Co	Assessed	Year	Co	Assessed							
2018	400	2,111,500	2017	400	2,111,500	2016	400	2,111,500	2016	400	2,111,500							
	400	272,800		400	272,800		400	272,800		400	272,800							
	400	25,700		400	25,700		400	25,700		400	25,700							
Total		2410000	Total		2410000	Total		2410000	Total		2410000							

EXEMPTIONS				OTHER ASSESSMENTS			
Year	Code	Description	Amount	Code	Description	Number	Amount
Total			0.00				

AG DISTRICT			
APPRAISED VALUE SUMMARY			
Appraised Bldg. Value (Card)		2,111,500	
Appraised XF (B) Value (Bldg)		0	
Appraised OB (B) Value (Bldg)		25,700	
Appraised Land Value		272,800	
Special Land Value		0	
Total Appraised Parcel Value		2,410,000	
Valuation Method		C	
Exemption		0	
Adjustment			
Total Appraised Parcel Value		2,410,000	

ASSESSING NEIGHBORHOOD				
NBHD	NBHD Name	Street Index Name	District Code	Class Code
0001			T17	04

**NOTES**

VISIT / CHANGE HISTORY										
Date	Type	IS	ID	Cd	Purpose/Result	Notes				

LAND LINE VALUATION SECTION																				
B	Use co	Description	Zone	D	Land	Land Type	Units	Unit Price	I. Fact	S.A.	Ac Di	C. Fact	St. Idx	Adj	Notes	Special Pricing	Size	Adj Unit Pric	Land Value	
12	400R	Comm - Indl -					0.000	AC	1.00	1.000	5	1.00		1.00			0	1.000	1.00	0
Total Card Land Units							0.000	AC	Parcel Total Land Area			8.0000	Total Land Value							0

CONSTRUCTION DETAIL			CONSTRUCTION DETAIL (CONTINUED)		
Element	Cd	Description	Element	Cd	Description
Model	01	Residential	Chimney - 1P		
Building Class	30	COMMERCIAL	Chimney - 2M		
Style	006	WALKUP APARTMENT	Chimney - 2P		
Grade	24	C			
Foundation Ty	BR	Brick			
Exterior Wall 1	02	Brick Veneer			
Exterior Wall 2	01	Wood Lap Siding			
Roof Structure	01	Gable			
Roof Cover 1	01	Composition Shingle			
Roof Cover 2					
Interior Wall 1	01	Dry Wall			
Interior Wall 2					
Interior Floor 1	01	Carpet			
Interior Floor 2	02	Vinyl			
Interior Floor 3					
Fuel Type 1	E	Electric			
Fuel Type 2					
Heat Type 1	01	Central Heat			
Heat Type 2					
AC Type	02	Central Air			
Total Rooms	32				
Bedrooms	0				
Full Bath(s)	8				
Full Bath Grad	C				
Half Bath(s)	0				
Half Bath Grad					
Extra Fixture(s)		Average Quality Constructi			
Extra Fix Grad					
Fireplace Ope	0				
Fireplace(s)					
Chimney - 1M					
Chimnev - 1P					

MIXED USE		
Code	Description	Percentage
400R	Comm - Indl - Res	100
		0
		0

COST / MARKET VALUATION		
Base Rate		45.18
RCN		166,369
Net Other Adj		29,831
RCN		166,369
AYB		1975
Effective Year Built		
Depreciation Code	A	
Remodel Rating		
Year Remodeled		
EYB DPR	20	
Functional Obsol	0	
Economic Obsol		
Cost Trend Factor	1	
Condition		
% Complete	80	
RCNLD	0	
Dep % Ovr		
Dep Ovr Comment		
Misc Imp Ovr		
Misc Imp Ovr Comment		
Cost to Cure Ovr		
Cost to Cure Ovr Comment		

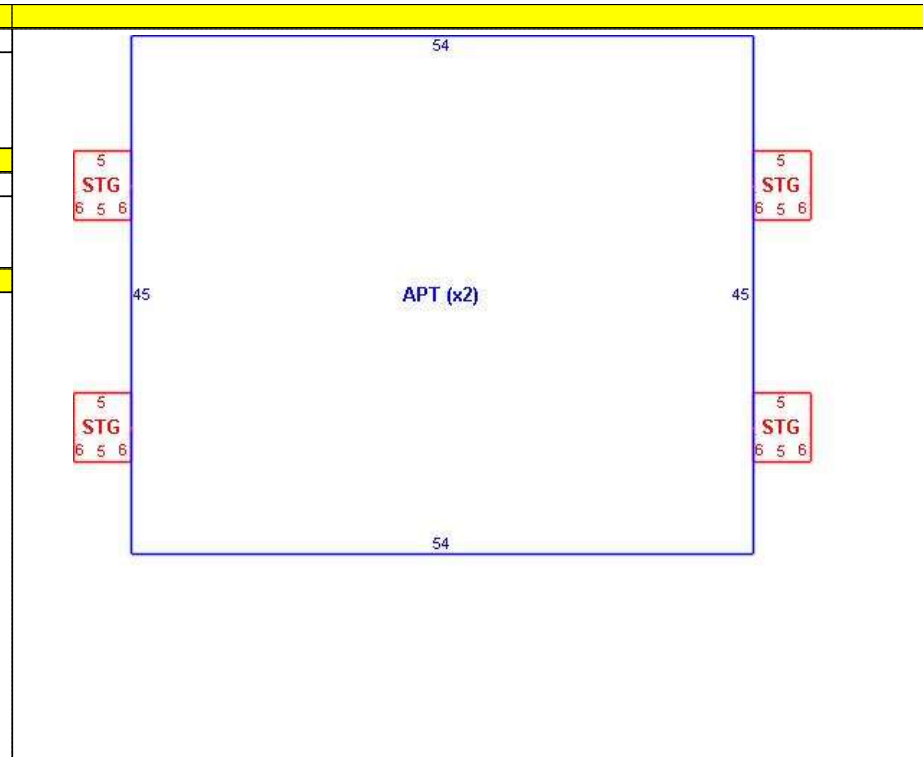

OB - OUTBUILDING & YARD ITEMS(L) / XF - BUILDING EXTRA FEATURES(B)											
Code	Description	Su	Sub Desc	Lan	Units	Unit Price	Year	%	Cond	#	Apprais Valu

BUILDING SUB-AREA SUMMARY SECTION						
SUBAR	Description	LIVING	GROSS	EFF AR		
APT	Apartment	4,860	4,860	2,673		
STG	Storage	0	120	19		
Ttl Gross Liv / Lease Area		4,860	4,980	2,692		

CURRENT OWNER			TOPO	UTILITIES	STRT / ROAD	ZONING	CURRENT ASSESSMENT				
NEW WESTSIDE VILLAGE I LIMITED PARTNERSHIP % T M ASS. MGMT INC 1375 PICCARD DR STE 150	0	Unknown	0	All Public Utiliti	0	Paved	Descript	Co	LU MRKT Value	Appraised	Assessed
	0	Level	0	Unknown			Building	400	0	2,111,500	2,111,500
	0	Unknown	0	Unknown			Land	400	0	272,800	272,800
<b>SUPPLEMENTAL DATA</b>							Outbldg	400	0	25,700	25,700
ROCKVILLE MD 20850			Plat	NBHD Cod T17-8:South Boston - B		Lister Date					
			Info By	E:Estimated Informatio		Mobile Ho	0				
			Exempt	00:No		Tracts	0				
			Total Acre	8		Road Num	654				
			Lister			Gis ID	059-01-00-0001				
Parcel Description WESTSIDE VILLAGE APTS.							Total		2,410,000		2,410,000
							Total Appraised Land			272,800	

RECORD OF OWNERSHIP							WILL BK/PG	INSTRUMENT	BK-VOL/PAGE	SALE DATE	Q/	SALE PR	PREVIOUS ASSESSMENTS (HISTORY)					
NEW WESTSIDE VILLAGE I LIMITED	0	0	10-533	1063	761	02-26-2010	Q	1,400,00	Year	Code	Assessed	Year	Code	Assessed	Year	Co	Assessed	
WESTSIDE VILLAGE ASSOCIATES	0	0		0	0	01-01-2010		0	2018	400	2,111,500	2017	400	2,111,500	2016	400	2,111,500	
	0	0								400	272,800		400	272,800		400	272,800	
	0	0								400	25,700		400	25,700		400	25,700	
Total									2410000		Total		2410000		Total		2410000	

EXEMPTIONS				OTHER ASSESSMENTS				AG DISTRICT				
Year	Code	Description	Amount	Code	Description	Number	Amount	Comm Int				
Total			0.00									

ASSESSING NEIGHBORHOOD					
NBHD	NBHD Name	Street Index Name	District Code	Class Code	
0001			T17	04	

NOTES																

  

APPRAISED VALUE SUMMARY																
Appraised Bldg. Value (Card)														2,111,500		
Appraised XF (B) Value (Bldg)														0		
Appraised OB (B) Value (Bldg)														25,700		
Appraised Land Value														272,800		
Special Land Value														0		
Total Appraised Parcel Value														2,410,000		
Valuation Method C																
Exemption 0																
Adjustment																
Total Appraised Parcel Value														2,410,000		

VISIT / CHANGE HISTORY																
Date	Type	IS	ID	Cd	Purpose/Result	Notes										

LAND LINE VALUATION SECTION																					
B	Use co	Description	Zone	D	Land	Land Type	Units	Unit Price	I. Fact	S.A.	Ac Di	C. Fact	St. Idx	Adj	Notes	Special Pricing	Size	Adj Unit Pric	Land Value		
13	400R	Comm - Indl -					0.000	AC	1.00	1.000	5	1.00		1.00			0	1.000	1.00	0	
Total Card Land Units							0.000	AC	Parcel Total Land Area			8.0000								Total Land Value	0

CONSTRUCTION DETAIL			CONSTRUCTION DETAIL (CONTINUED)		
Element	Cd	Description	Element	Cd	Description
Model	01	Residential	Chimney - 1P		CENTRAL HEAT
Building Class	30	COMMERCIAL	Chimney - 2M		
Style	006	WALKUP APARTMENT	Chimney - 2P		
Grade	24	C			
Foundation Ty	BR	Brick	<b>MIXED USE</b>		
Exterior Wall 1	02	Brick Veneer	Code	Description	Percentage
Exterior Wall 2			400R	Comm - Indl - Res	100
Roof Structure	01	Gable			0
Roof Cover 1	01	Composition Shingle			0
Roof Cover 2			<b>COST / MARKET VALUATION</b>		
Interior Wall 1	01	Dry Wall	Base Rate	45.18	
Interior Wall 2			RCN	182,545	
Interior Floor 1	01	Carpet	Net Other Adj	35,632	
Interior Floor 2	02	Vinyl	RCN	182,545	
Interior Floor 3			AYB	1975	
Fuel Type 1	E	Electric	Effective Year Built		
Fuel Type 2			Depreciation Code	A	
Heat Type 1	01	Central Heat	Remodel Rating		
Heat Type 2			Year Remodeled		
AC Type	02	Central Air	EYB DPR	20	
Total Rooms	32		Functional Obsol	0	
Bedrooms	0		Economic Obsol		
Full Bath(s)	8		Cost Trend Factor	1	
Full Bath Grad	C		Condition		
Half Bath(s)	0		% Complete	80	
Half Bath Grad			RCNLD	0	
Extra Fixture(s)		Average Quality Constructi	Dep % Ovr		
Extra Fix Grad			Dep Ovr Comment		
Fireplace Ope	0		Misc Imp Ovr		
Fireplace(s)			Misc Imp Ovr Comment		
Chimney - 1M			Cost to Cure Ovr		
Chimnev - 1P			Cost to Cure Ovr Comment		

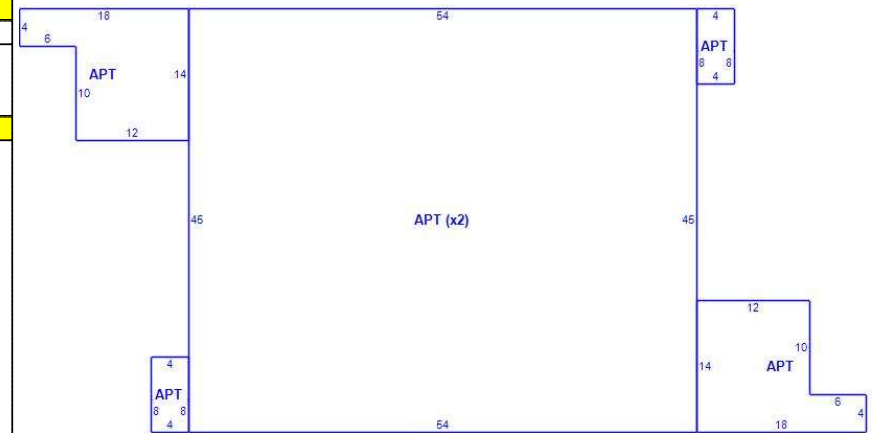

OB - OUTBUILDING & YARD ITEMS(L) / XF - BUILDING EXTRA FEATURES(B)											
Code	Description	Su	Sub Desc	Lan	Units	Unit Price	Year	%	Cond	#	Apprais Valu

BUILDING SUB-AREA SUMMARY SECTION						
SUBAR	Description	LIVING	GROSS	EFF AR		
APT	Apartment	5,308	5,308	2,919		
Ttl Gross Liv / Lease Area		5,308	5,308	2,919		

CURRENT OWNER			TOPO	UTILITIES	STRT / ROAD	ZONING	CURRENT ASSESSMENT				
NEW WESTSIDE VILLAGE I LIMITED PARTNERSHIP % T M ASS. MGMT INC 1375 PICCARD DR STE 150  ROCKVILLE MD 20850			0 Unknown	0 All Public Utiliti	0 Paved		Describe	Co	LU MRKT Value	Appraised	Assessed
			0 Level	0 Unknown			Building	400	0	2,111,500	2,111,500
			0 Unknown	0 Unknown			Land	400	0	272,800	272,800
<b>SUPPLEMENTAL DATA</b>							Outldg	400	0	25,700	25,700
			Plat	Lister Date							
			NBHD Cod T17-8:South Boston - B	Mobile Ho 0							
			Info By E:Estimated Informatio								
			Exempt 00:No	Tracts 0							
			Total Acre 8	Road Num 654							
			Lister	Gis ID 059-01-00-0001							
							Total			2,410,000	2,410,000

Parcel Description WESTSIDE VILLAGE APTS. Total Appraised Land 272,800

RECORD OF OWNERSHIP							PREVIOUS ASSESSMENTS (HISTORY)										
WILL BK/PG	INSTRUMENT	BK-VOL/PAGE	SALE DATE	Q	SALE PR	Year	Code	Assessed	Year	Code	Assessed	Year	Co	Assessed			
0 0	10-533	1063 761	02-26-2010	Q	1,400,00	2018	400	2,111,500	2017	400	2,111,500	2016	400	2,111,500			
0 0			01-01-2010		0		400	272,800		400	272,800		400	272,800			
0 0								400	25,700		400	25,700		400	25,700		
						Total		2410000	Total		2410000	Total		2410000			

EXEMPTIONS				OTHER ASSESSMENTS			
Year	Code	Description	Amount	Code	Description	Number	Amount
Total			0.00				

AG DISTRICT			
APPRAISED VALUE SUMMARY			
Appraised Bldg. Value (Card)		2,111,500	
Appraised XF (B) Value (Bldg)		0	
Appraised OB (B) Value (Bldg)		25,700	
Appraised Land Value		272,800	
Special Land Value		0	
Total Appraised Parcel Value		2,410,000	
Valuation Method		C	
Exemption		0	
Adjustment			
Total Appraised Parcel Value		2,410,000	

ASSESSING NEIGHBORHOOD				
NBHD	NBHD Name	Street Index Name	District Code	Class Code
0001			T17	04

**NOTES**

VISIT / CHANGE HISTORY										
Date	Type	IS	ID	Cd	Purpose/Result	Notes				

LAND LINE VALUATION SECTION																				
B	Use co	Description	Zone	D	Land	Land Type	Units	Unit Price	I. Fact	S.A.	Ac Di	C. Fact	St. Idx	Adj	Notes	Special Pricing	Size	Adj Unit Pric	Land Value	
14	400R	Comm - Incl -					0.000	AC	1.00	1.000	5	1.00		1.00			0	1.000	1.00	0
Total Card Land Units							0.000	AC	Parcel Total Land Area			8.0000	Total Land Value							0

CONSTRUCTION DETAIL			CONSTRUCTION DETAIL (CONTINUED)		
Element	Cd	Description	Element	Cd	Description
Model	01	Residential	Chimney - 1P		CENTRAL HEAT
Building Class	30	COMMERCIAL	Chimney - 2M		
Style	006	WALKUP APARTMENT	Chimney - 2P		
Grade	24	C			
Foundation Ty	BR	Brick			
Exterior Wall 1	02	Brick Veneer			
Exterior Wall 2					
Roof Structure	01	Gable			
Roof Cover 1	01	Composition Shingle			
Roof Cover 2					
Interior Wall 1	01	Dry Wall			
Interior Wall 2					
Interior Floor 1	01	Carpet			
Interior Floor 2	02	Vinyl			
Interior Floor 3					
Fuel Type 1	E	Electric			
Fuel Type 2					
Heat Type 1	01	Central Heat			
Heat Type 2					
AC Type	02	Central Air			
Total Rooms	32				
Bedrooms	0				
Full Bath(s)	8				
Full Bath Grad	C				
Half Bath(s)	0				
Half Bath Grad					
Extra Fixture(s)		Average Quality Constructi			
Extra Fix Grad					
Fireplace Ope	0				
Fireplace(s)					
Chimney - 1M					
Chimnev - 1P					

MIXED USE		
Code	Description	Percentage
400R	Comm - Indl - Res	100
		0
		0

COST / MARKET VALUATION		
Base Rate		45.18
RCN		182,545
Net Other Adj		35,632
RCN		182,545
AYB		1975
Effective Year Built		
Depreciation Code		A
Remodel Rating		
Year Remodeled		
EYB DPR		20
Functional Obsol		0
Economic Obsol		
Cost Trend Factor		1
Condition		
% Complete		80
RCNLD		0
Dep % Ovr		
Dep Ovr Comment		
Misc Imp Ovr		
Misc Imp Ovr Comment		
Cost to Cure Ovr		
Cost to Cure Ovr Comment		

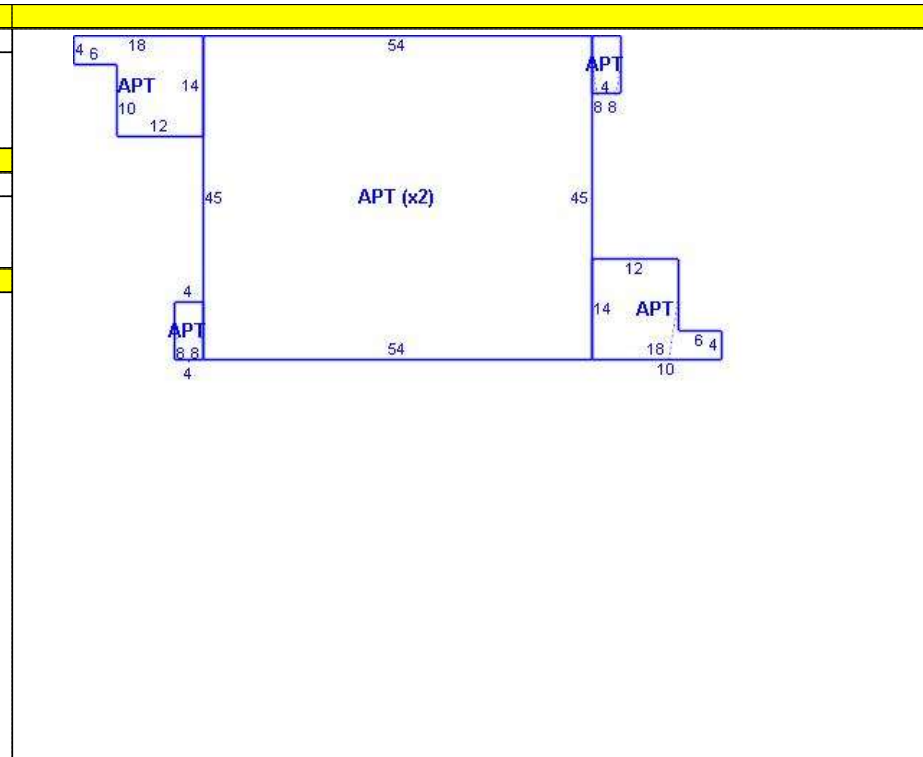

OB - OUTBUILDING & YARD ITEMS(L) / XF - BUILDING EXTRA FEATURES(B)											
Code	Description	Su	Sub Desc	Lan	Units	Unit Price	Year	%	Cond	#	Apprais Valu

BUILDING SUB-AREA SUMMARY SECTION						
SUBAR	Description	LIVING	GROSS	EFF AR		
APT	Apartment	5,308	5,308	2,919		
Ttl Gross Liv / Lease Area		5,308	5,308	2,919		

CURRENT OWNER			TOPO	UTILITIES	STRT / ROAD	ZONING	CURRENT ASSESSMENT				
NEW WESTSIDE VILLAGE I LIMITED PARTNERSHIP % T M ASS. MGMT INC 1375 PICCARD DR STE 150  ROCKVILLE MD 20850			0 Unknown	0 All Public Utiliti	0 Paved		Describe	Co	LU MRKT Value	Appraised	Assessed
			0 Level	0 Unknown			Building	400	0	2,111,500	2,111,500
			0 Unknown	0 Unknown			Land	400	0	272,800	272,800
<b>SUPPLEMENTAL DATA</b>							Outbldg	400	0	25,700	25,700
Plat			NBHD Cod T17-8:South Boston - B			Lister Date					
Info By			E:Estimated Informatio			Mobile Ho 0					
Exempt 00:No			Tracts 0			Road Num 654					
Total Acre 8			Road Num 654			Gis ID 059-01-00-0001					
Lister											
							Total		2,410,000		2,410,000

Parcel Description WESTSIDE VILLAGE APTS. Total Appraised Land 272,800

RECORD OF OWNERSHIP							WILL BK/PG	INSTRUMENT	BK-VOL/PAGE	SALE DATE	Q/	SALE PR	PREVIOUS ASSESSMENTS (HISTORY)					
Year	Code	Assessed	Year	Code	Assessed	Year	Co	Assessed	Year	Co	Assessed							
2018	400	2,111,500	2017	400	2,111,500	2016	400	2,111,500	2016	400	2,111,500							
	400	272,800		400	272,800		400	272,800		400	272,800							
	400	25,700		400	25,700		400	25,700		400	25,700							
Total		2410000	Total		2410000	Total		2410000	Total		2410000							

EXEMPTIONS				OTHER ASSESSMENTS			
Year	Code	Description	Amount	Code	Description	Number	Amount
Total			0.00				

AG DISTRICT			
APPRAISED VALUE SUMMARY			
Appraised Bldg. Value (Card)		2,111,500	
Appraised XF (B) Value (Bldg)		0	
Appraised OB (B) Value (Bldg)		25,700	
Appraised Land Value		272,800	
Special Land Value		0	
Total Appraised Parcel Value		2,410,000	
Valuation Method		C	
Exemption		0	
Adjustment			
Total Appraised Parcel Value		2,410,000	

ASSESSING NEIGHBORHOOD					
NBHD	NBHD Name	Street Index Name	District Code	Class Code	
0001			T17	04	

NOTES					

VISIT / CHANGE HISTORY										
Date	Type	IS	ID	Cd	Purpose/Result	Notes				

LAND LINE VALUATION SECTION																				
B	Use co	Description	Zone	D	Land	Land Type	Units	Unit Price	I. Fact	S.A.	Ac Di	C. Fact	St. Idx	Adj	Notes	Special Pricing	Size	Adj Unit Pric	Land Value	
15	400R	Comm - Incl -					0.000	AC	1.00	1.000	5	1.00		1.00			0	1.000	1.00	0
Total Card Land Units							0.000	AC	Parcel Total Land Area			8.0000	Total Land Value							0



CONSTRUCTION DETAIL			CONSTRUCTION DETAIL (CONTINUED)		
Element	Cd	Description	Element	Cd	Description
Model	01	Residential	Chimney - 1P		CENTRAL HEAT
Building Class	30	COMMERCIAL	Chimney - 2M		
Style	006	WALKUP APARTMENT	Chimney - 2P		
Grade	24	C			
Foundation Ty	BR	Brick	<b>MIXED USE</b>		
Exterior Wall 1	02	Brick Veneer	Code	Description	Percentage
Exterior Wall 2	01	Wood Lap Siding	400R	Comm - Incl - Res	100
Roof Structure	01	Gable			0
Roof Cover 1	01	Composition Shingle			0
Roof Cover 2			<b>COST / MARKET VALUATION</b>		
Interior Wall 1	01	Dry Wall	Base Rate		45.18
Interior Wall 2			RCN		156,610
Interior Floor 1	01	Carpet	Net Other Adj		28,878
Interior Floor 2	02	Vinyl	RCN		156,610
Interior Floor 3			AYB		1975
Fuel Type 1	E	Electric	Effective Year Built		
Fuel Type 2			Depreciation Code	A	
Heat Type 1	01	Central Heat	Remodel Rating		
Heat Type 2			Year Remodeled		
AC Type	02	Central Air	EYB DPR	20	
Total Rooms	0		Functional Obsol	0	
Bedrooms	0		Economic Obsol		
Full Bath(s)	8		Cost Trend Factor	1	
Full Bath Grad	C		Condition		
Half Bath(s)	0		% Complete		
Half Bath Grad				80	
Extra Fixture(s)		Average Quality Constructi	RCNLD	0	
Extra Fix Grad			Dep % Ovr		
Fireplace Ope	0		Dep Ovr Comment		
Fireplace(s)			Misc Imp Ovr		
Chimney - 1M			Misc Imp Ovr Comment		
Chimnev - 1P			Cost to Cure Ovr		
			Cost to Cure Ovr Comment		

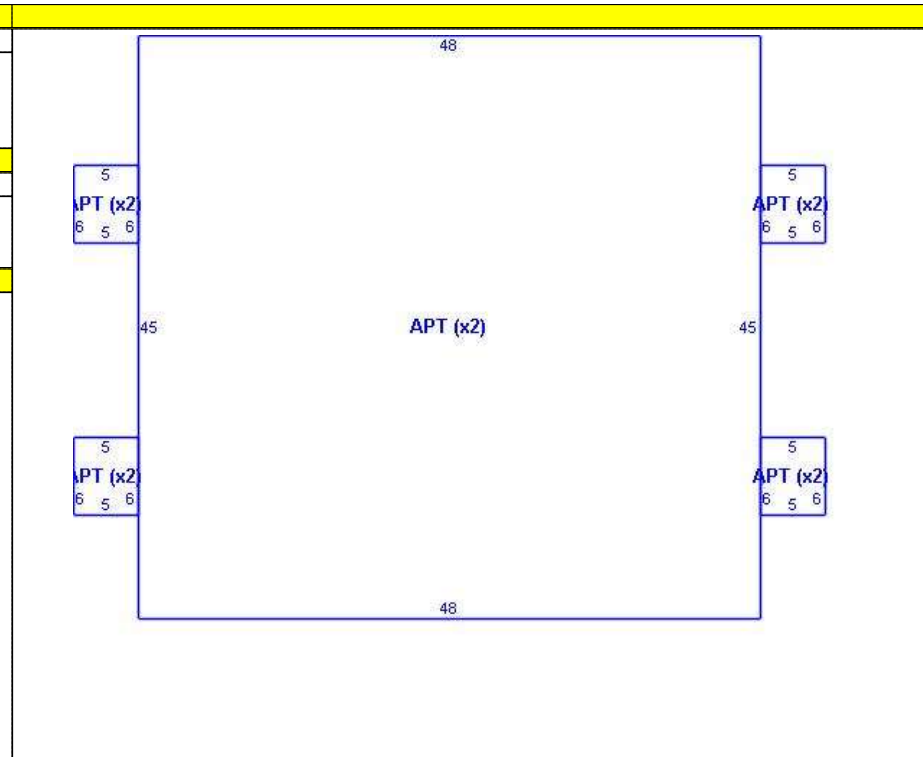

OB - OUTBUILDING & YARD ITEMS(L) / XF - BUILDING EXTRA FEATURES(B)											
Code	Description	Su	Sub Desc	Lan	Units	Unit Price	Year	%	Cond	#	Apprais Valu

BUILDING SUB-AREA SUMMARY SECTION						
SUBAR	Description	LIVING	GROSS	EFF AR		
APT	Apartment	4,560	4,560	2,508		
Ttl Gross Liv / Lease Area		4,560	4,560	2,508		

CURRENT OWNER			TOPO	UTILITIES	STRT / ROAD	ZONING	CURRENT ASSESSMENT				
NEW WESTSIDE VILLAGE I LIMITED PARTNERSHIP % T M ASS. MGMT INC 1375 PICCARD DR STE 150  ROCKVILLE MD 20850			0 Unknown	0 All Public Utiliti	0 Paved		Describe	Co	LU MRKT Value	Appraised	Assessed
			0 Level	0 Unknown			Building	400	0	2,111,500	2,111,500
			0 Unknown	0 Unknown			Land	400	0	272,800	272,800
<b>SUPPLEMENTAL DATA</b>							Outbldg	400	0	25,700	25,700
			Plat	Lister Date							
			NBHD Cod T17-8:South Boston - B	Mobile Ho 0							
			Info By E:Estimated Informatio								
			Exempt 00:No	Tracts 0							
			Total Acre 8	Road Num 654							
			Lister	Gis ID 059-01-00-0001							
							Total			2,410,000	2,410,000

Parcel Description WESTSIDE VILLAGE APTS. Total Appraised Land 272,800

RECORD OF OWNERSHIP							WILL BK/PG	INSTRUMENT	BK-VOL/PAGE	SALE DATE	Q/	SALE PR	PREVIOUS ASSESSMENTS (HISTORY)								
NEW WESTSIDE VILLAGE I LIMITED							0 0	10-533	1063 761	02-26-2010	Q	1,400,00	Year	Code	Assessed	Year	Code	Assessed	Year	Co	Assessed
WESTSIDE VILLAGE ASSOCIATES							0 0		0 0	01-01-2010		0	2018	400	2,111,500	2017	400	2,111,500	2016	400	2,111,500
							0 0							400	272,800		400	272,800		400	272,800
							0 0							400	25,700		400	25,700		400	25,700
												Total	2410000	Total	2410000	Total	2410000	Total	2410000		

EXEMPTIONS				OTHER ASSESSMENTS			
Year	Code	Description	Amount	Code	Description	Number	Amount
Total			0.00				

AG DISTRICT			
<b>APPRAISED VALUE SUMMARY</b>			
Appraised Bldg. Value (Card)			2,111,500
Appraised XF (B) Value (Bldg)			0
Appraised OB (B) Value (Bldg)			25,700
Appraised Land Value			272,800
Special Land Value			0
Total Appraised Parcel Value			2,410,000
Valuation Method			C
Exemption			0
Adjustment			
Total Appraised Parcel Value			2,410,000

ASSESSING NEIGHBORHOOD				
NBHD	NBHD Name	Street Index Name	District Code	Class Code
0001			T17	04

NOTES						

VISIT / CHANGE HISTORY																				
Date	Type	IS	ID	Cd	Purpose/Result	Notes														
LAND LINE VALUATION SECTION																				
B	Use co	Description	Zone	D	Land	Land Type	Units	Unit Price	I. Fact	S.A.	Ac Di	C. Fact	St. Idx	Adj	Notes	Special Pricing	Size	Adj Unit Pric	Land Value	
16	400R	Comm - Indl -					0.000 AC	1.00	1.000	5		1.00		1.00			0	1.000	1.00	0
Total Card Land Units							0.000 AC	Parcel Total Land Area			8.0000								Total Land Value	0

**CONSTRUCTION DETAIL** **CONSTRUCTION DETAIL (CONTINUED)**

Element	Cd	Description	Element	Cd	Description
Model	01	Residential	Chimney - 1P		CENTRAL HEAT
Building Class	30	COMMERCIAL	Chimney - 2M		
Style	006	WALKUP APARTMENT	Chimney - 2P		
Grade	24	C			
Foundation Ty	BR	Brick	<b>MIXED USE</b>		
Exterior Wall 1	02	Brick Veneer	Code	Description	Percentage
Exterior Wall 2			400R	Comm - Indl - Res	100
Roof Structure	01	Gable			0
Roof Cover 1	01	Composition Shingle			0
Roof Cover 2			<b>COST / MARKET VALUATION</b>		
Interior Wall 1	01	Dry Wall	Base Rate	45.18	
Interior Wall 2			RCN	98,890	
Interior Floor 1	01	Carpet	Net Other Adj	18,456	
Interior Floor 2	02	Vinyl	RCN	98,890	
Interior Floor 3			AYB	1975	
Fuel Type 1	E	Electric	Effective Year Built		
Fuel Type 2			Depreciation Code	A	
Heat Type 1	01	Central Heat	Remodel Rating		
Heat Type 2			Year Remodeled		
AC Type	02	Central Air	EYB DPR	20	
Total Rooms	0		Functional Obsol	0	
Bedrooms	0		Economic Obsol		
Full Bath(s)	4		Cost Trend Factor	1	
Full Bath Grad	C		Condition		
Half Bath(s)	0		% Complete	80	
Half Bath Grad			RCNLD	0	
Extra Fixture(s)		Average Quality Constructi	Dep % Ovr		
Extra Fix Grad			Dep Ovr Comment		
Fireplace Ope	0		Misc Imp Ovr		
Fireplace(s)			Misc Imp Ovr Comment		
Chimney - 1M			Cost to Cure Ovr		
Chimnev - 1P			Cost to Cure Ovr Comment		

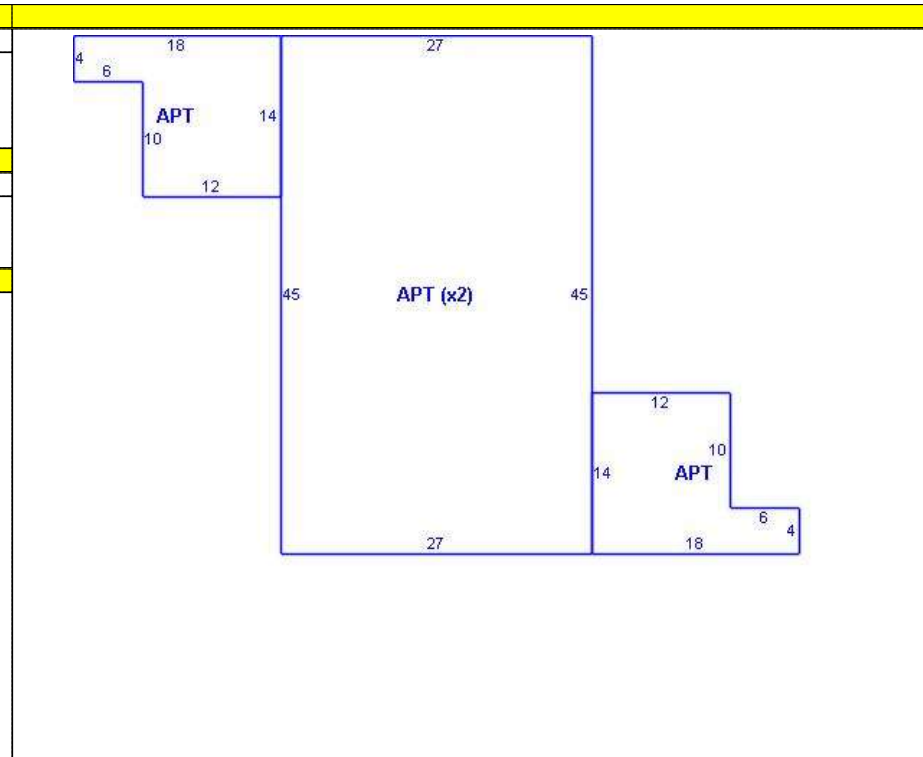

**OB - OUTBUILDING & YARD ITEMS(L) / XF - BUILDING EXTRA FEATURES(B)**

Code	Description	Su	Sub Desc	Lan	Units	Unit Price	Year	%	Cond	#	Apprais Valu

**BUILDING SUB-AREA SUMMARY SECTION**

SUBAR	Description	LIVING	GROSS	EFF AR
APT	Apartment	2,814	2,814	1,548
Ttl Gross Liv / Lease Area		2,814	2,814	1,548

CURRENT OWNER			TOPO	UTILITIES	STRT / ROAD	ZONING	CURRENT ASSESSMENT				
NEW WESTSIDE VILLAGE I LIMITED PARTNERSHIP % T M ASS. MGMT INC 1375 PICCARD DR STE 150	0	Unknown	0	All Public Utiliti	0	Paved	Describe	Co	LU MRKT Value	Appraised	Assessed
	0	Level	0	Unknown			Building	400	0	2,111,500	2,111,500
	0	Unknown	0	Unknown			Land	400	0	272,800	272,800
<b>SUPPLEMENTAL DATA</b>							Outbldg	400	0	25,700	25,700
ROCKVILLE MD 20850			Plat	NBHD Cod T17-8:South Boston - B		Lister Date					
			Info By	E:Estimated Informatio		Mobile Ho	0				
			Exempt	00:No		Tracts	0				
			Total Acre	8		Road Num	654				
			Lister			Gis ID	059-01-00-0001				
Parcel Description WESTSIDE VILLAGE APTS.							Total		2,410,000		2,410,000
							Total Appraised Land				272,800

RECORD OF OWNERSHIP							WILL BK/PG	INSTRUMENT	BK-VOL/PAGE	SALE DATE	Q	SALE PR	PREVIOUS ASSESSMENTS (HISTORY)					
NEW WESTSIDE VILLAGE I LIMITED	0	0	10-533	1063	761	02-26-2010	Q	1,400,00	Year	Code	Assessed	Year	Code	Assessed	Year	Co	Assessed	
WESTSIDE VILLAGE ASSOCIATES	0	0		0	0	01-01-2010		0	2018	400	2,111,500	2017	400	2,111,500	2016	400	2,111,500	
	0	0								400	272,800		400	272,800		400	272,800	
	0	0								400	25,700		400	25,700		400	25,700	
							Total		2410000		Total		2410000		Total		2410000	

EXEMPTIONS				OTHER ASSESSMENTS				AG DISTRICT				
Year	Code	Description	Amount	Code	Description	Number	Amount	Comm Int				
Total			0.00									

ASSESSING NEIGHBORHOOD					
NBHD	NBHD Name	Street Index Name	District Code	Class Code	
0001			T17	04	

NOTES																

VISIT / CHANGE HISTORY																
Date	Type	IS	ID	Cd	Purpose/Result	Notes										

LAND LINE VALUATION SECTION																					
B	Use co	Description	Zone	D	Land	Land Type	Units	Unit Price	I. Fact	S.A.	Ac Di	C. Fact	St. Idx	Adj	Notes	Special Pricing	Size	Adj Unit Pric	Land Value		
17	400R	Comm - Indl -					0.000	AC	1.00	1.000	5	1.00		1.00			0	1.000	1.00	0	
Total Card Land Units							0.000	AC	Parcel Total Land Area			8.0000								Total Land Value	0

CONSTRUCTION DETAIL			CONSTRUCTION DETAIL (CONTINUED)		
Element	Cd	Description	Element	Cd	Description
Model	01	Residential	Chimney - 1P		
Building Class	30	COMMERCIAL	Chimney - 2M		
Style	006	WALKUP APARTMENT	Chimney - 2P		
Grade	24	C			
Foundation Ty	BR	Brick			
Exterior Wall 1	02	Brick Veneer			
Exterior Wall 2					
Roof Structure	01	Gable			
Roof Cover 1	01	Composition Shingle			
Roof Cover 2					
Interior Wall 1	01	Dry Wall			
Interior Wall 2					
Interior Floor 1	01	Carpet			
Interior Floor 2	02	Vinyl			
Interior Floor 3					
Fuel Type 1	E	Electric			
Fuel Type 2					
Heat Type 1	01	Central Heat			
Heat Type 2					
AC Type	02	Central Air			
Total Rooms	0				
Bedrooms	0				
Full Bath(s)	8				
Full Bath Grad	C				
Half Bath(s)	0				
Half Bath Grad					
Extra Fixture(s)		Average Quality Constructi			
Extra Fix Grad					
Fireplace Ope	0				
Fireplace(s)					
Chimney - 1M					
Chimnev - 1P					

MIXED USE		
Code	Description	Percentage
400R	Comm - Indl - Res	100
		0
		0

COST / MARKET VALUATION		
Base Rate		45.18
RCN		214,063
Net Other Adj		39,744
RCN		214,063
AYB		1975
Effective Year Built		
Depreciation Code		A
Remodel Rating		
Year Remodeled		
EYB DPR	20	
Functional Obsol	0	
Economic Obsol		
Cost Trend Factor	1	
Condition		
% Complete	80	
RCNLD	0	
Dep % Ovr		
Dep Ovr Comment		
Misc Imp Ovr		
Misc Imp Ovr Comment		
Cost to Cure Ovr		
Cost to Cure Ovr Comment		

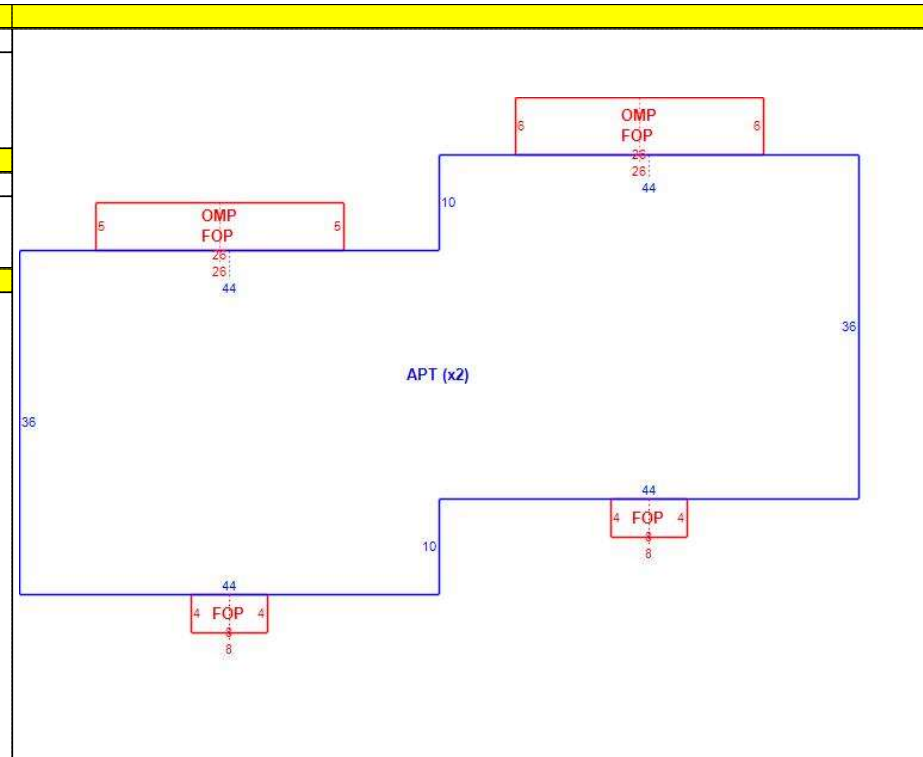

OB - OUTBUILDING & YARD ITEMS(L) / XF - BUILDING EXTRA FEATURES(B)											
Code	Description	Su	Sub Desc	Lan	Units	Unit Price	Year	%	Cond	#	Apprais Valu

BUILDING SUB-AREA SUMMARY SECTION						
SUBAR	Description	LIVING	GROSS	EFF AR		
APT	Apartment	6,336	6,336	3,485		
FOP	Open Porch	0	350	42		
OMP	Open Mas Porch	0	286	40		
Ttl Gross Liv / Lease Area		6,336	6,972	3,567		

CURRENT OWNER				TOPO	UTILITIES	STRT / ROAD	ZONING	CURRENT ASSESSMENT					
NEW WESTSIDE VILLAGE I LIMITED PARTNERSHIP % T M ASS. MGMT INC 1375 PICCARD DR STE 150  ROCKVILLE MD 20850				0	Unknown	0	All Public Utiliti	0	Paved	Description	Code	Appraised	Assessed
				0	Level	0	Unknown			Building	400	2,111,500	2,111,500
				0	Unknown	0	Unknown			Land	400	272,800	272,800
				<b>SUPPLEMENTAL DATA</b>				Outbldg	400	25,700	25,700		
				Plat	NBHD Cod T17-8:South Boston - B			Lister Date					
				Info By	E:Estimated Informatio			Mobile Ho	0				
				Exempt	00:No			Tracts	0				
				Total Acre	8			Road Num	654				
				Lister				Gis ID	059-01-00-0001				
										Total	2,410,000	2,410,000	

WESTSIDE VILLAGE APTS.

RECORD OF OWNERSHIP		WILL BK/PG	INSTRUMENT #	BK-VOL/PA	SALE DATE	Q/U	SALE PRI	PREVIOUS ASSESSMENTS (HISTORY)								
Year	Code	Assessed	Year	Code	Assessed	Year	Code	Assesse								
NEW WESTSIDE VILLAGE I LIMITED	0 0			1063 761	02-26-2010	Q	1,400,000	2018	400	2,111,500	2017	400	2,111,50	2016	400	2,111,5
WESTSIDE VILLAGE ASSOCIATES	0 0		10-533	0 0	01-01-2010		0		400	272,800		400	272,800		400	272,800
	0 0		8-3517						400	25,700		400	25,700		400	25,700
								Total	2410000		Total	2410000		Total	2410000	

EXEMPTIONS				OTHER ASSESSMENTS				AG DISTRICT			
Year	Code	Description	Amount	Code	Description	Number	Amount	Comm Int			
			Total	0.00							

ASSESSING NEIGHBORHOOD				
NBHD	NBHD Name	Street Index Name	District Code	Class Code
0001			T17	04

NOTES				

VISIT / CHANGE HISTORY						NOTES
Date	Type	IS	ID	Cd	Purpose/Result	
04-04-2017			PH	18	REASSESSMENT	

LAND LINE VALUATION SECTION																				
B	Use co	Description	Zone	D	Land	Land Type	Units	Unit Price	I. Fact	S.A.	Ac Di	C. Fact	St. Idx	Adj	Notes	Special Pricing	Size	Adj Unit Pric	Land Value	
18	400C	Comm - Indl					0.000	AC	1.00	1.000	C	1.00		1.00			0	1.000	1.00	0
Total Card Land Units							0.000	AC	Parcel Total Land Area			8.0000	Total Land Value							272,800

CONSTRUCTION DETAIL						CONSTRUCTION DETAIL (CONTINUED)							
Element	Cd	Description	Element	Cd	Description								
Style	061	TYPICAL OFFICE	Full Bath Grade	C	Average Quality Constructi								
Model	94	Com/Ind	Chimney - 2P										
Grade	24	C	Total Rooms	0									
Stories	1					<b>MIXED USE</b>							
Total Living Are	2258.00		Code	Description	Percentage								
Exterior Wall 2			400C	Comm - Indl	100								
Attic - Fin					0								
Foundation	BR	Brick			0								
Attic - Semi					0								
Roof Structure	01	Gable				<b>COST / MARKET VALUATION</b>							
Attic - Unfin			Base Rate		63.66								
Roof Cover 1	01	Composition Shingle	RCN		166,222								
Roof Cover 2			Net Other Adj		12,632								
Interior Wall 1	01	Dry Wall	RCN		166,222								
Interior Wall 2			AYB		1975								
Fireplace(s)			Effective Year Built										
Class	30	COMMERCIAL	Depreciation Code		A								
Bldg Use	400C	Comm - Indl	Remodel Rating										
Chimney - 1M			Year Remodeled										
AC Type	02	Central Air	EYB DPR		20								
Chimney - 1P	E	CENTRAL HEAT	Functional Obsol		0								
		Electric	Economic Obsol										
Interior Floor 1	05	Asphalt Tile	Cost Trend Factor		1								
Exterior Wall 1	02	Brick Veneer	Condition										
Interior Floor 2			% Complete		80								
Interior Floor 3			RCNLD		0								
Heat Type 1	01	Central Heat	Dep % Ovr										
Wall Height		0.0000	Dep Ovr Comment										
Half Bath Grade			Misc Imp Ovr										
Extra Fixture(s)			Misc Imp Ovr Comment										
Half Bath(s)	0		Cost to Cure Ovr										
			Cost to Cure Ovr Comment										
<b>OB - OUTBUILDING &amp; YARD ITEMS(L) / XF - BUILDING EXTRA FEATURES(B)</b>													
Code	Description	Su	Sub Desc	Lan	Units	Unit Price	Year	%	Dep R	Cond	Qu	Adj	Apprais Va
SHED	Shed	ST	Storage -	L	0	9.79	2014	100	0.00	A	32	1.00	700
FNC	Fence	CL	Chain Lin	L	0	7.65	2014	100	0.00	A	32	1.00	3,000
<b>BUILDING SUB-AREA SUMMARY SECTION</b>													
SUBAR	Description	LIVING	GROSS	EFF AR									
1FF	1st Floor Finished	858	858	858									
OFF	Office	1,400	1,400	1,400									
OMP	Open Mas Porch	0	24	4									
Ttl Gross Liv / Lease Area		2,258	2,282	2,262									

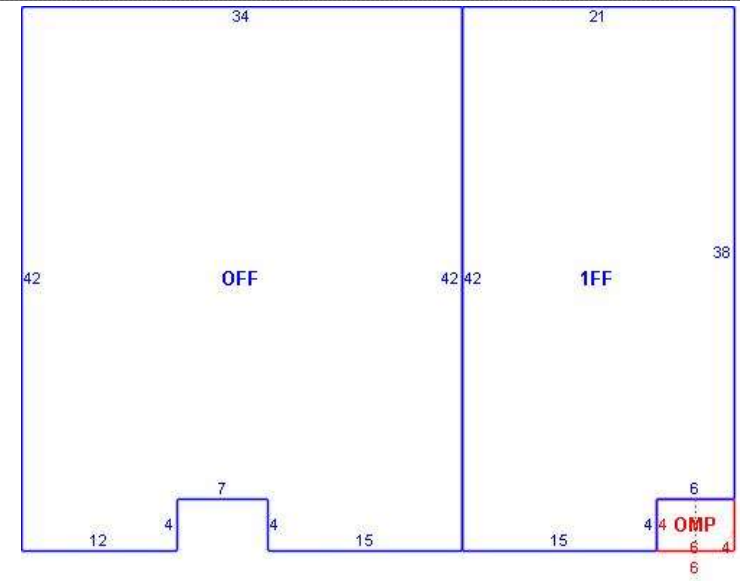

F

Third-Party RESNET  
Rater Certification  
(MANDATORY)





Appendix F
RESNET Rater Certification of Development Plans

I certify that the development's plans and specifications incorporate all items for the required baseline energy performance as indicated in Virginia's Qualified Allocation Plan (QAP). In the event the plans and specifications do not include requirements to meet the QAP baseline energy performance, then those requirements still must be met, even though the application is accepted for credits.

\*\*\*Please note that this may cause the Application to be ineligible for credits. The Requirements apply to any new, adaptive reuse or rehabilitated development (including those serving elderly and/or physically disabled households).

In addition provide HERS rating documentation as specified in the manual

New Construction - EnergyStar Certification
The development's design meets the criteria for the EnergyStar certification. Rater understands that before issuance of IRS Form 8609, applicant will obtain and provide EnergyStar Certification to VHDA.

X Rehabilitation -30% performance increase over existing, based on HERS Index Or Must evidence a HERS Index of 80 or better
Rater understands that before issuance of IRS Form 8609, rater must provide Certification to VHDA of energy performance.

Adaptive Reuse - Must evidence a HERS Index of 95 or better.
Rater understands that before issuance of IRS Form 8609, rater must provide Certification to VHDA of energy performance.

Additional Optional Certifications

I certify that the development's plans and specifications incorporate all items for the certification as indicated below, and I am a certified verifier of said certification. In the event the plans and specifications do not include requirements to obtain the certification, then those requirements still must be met, even though the application is accepted for credits. Rater understands that before issuance of IRS Form 8609, applicant will obtain and provide Certification to VHDA.

TRUE Earthcraft Certification - The development's design meets the criteria to obtain Viridiant's EarthCraft Multifamily program Gold certification or higher

LEED Certification - The development's design meets the criteria for the U.S. Green Building Council LEED green building certification.

National Green Building Standard (NGBS) - The development's design meets the criteria for meeting the NGBS Silver or higher standards to obtain certification

Enterprise Green Communities - The developmen's design meets the criteria for meeting meeting the requirements as stated in the Enterprise Green Communities Criteria for this developments construction type to obtain certification.

\*\*\*Please Note Raters must have completed 500+ ratings in order to certify this form

Signed: [Signature]

Date: 3/11/20

Printed Name: Matt Waring

RESNET Rater

Resnet Provider Agency
Viridiant

Signature [Signature]

Provider Contact and Phone/Email Sean Evensen-Shanley, 804-212-1934 ,sean.evensen-shanley@viridiant.org



# Home Energy Rating Certificate

## Projected Report

Rating Date:  
Registry ID:  
Ekotrope ID: ILXW1W02

### HERS® Index Score:

# 117

Your home's HERS score is a relative performance score. The lower the number, the more energy efficient the home. To learn more, visit [www.hersindex.com](http://www.hersindex.com)

### Annual Savings

# \$293

\*Relative to an average U.S. home

**Home:**  
2150 Sinai Road  
South Boston, VA 24592

**Builder:**

### Your Home's Estimated Energy Use:

	Use [MBtu]
Heating	16.1
Cooling	3.2
Hot Water	8.9
Lights/Appliances	19.4
Service Charges	
Generation (e.g. Solar)	0.0
<b>Total:</b>	<b>47.6</b>

**This home meets or exceeds the criteria of the following:**

### Rating Completed by:

**Energy Rater:** Matt Waring  
RESNET ID: 6729287

**Rating Company:** Viridiant  
1431 W. Main Street, Richmond, VA 23220

**Rating Provider:** Viridiant  
1431 W. Main Street, Richmond, VA 23220



Matt Waring, Certified Energy Rater  
Date: 3/11/20 at 4:27 PM

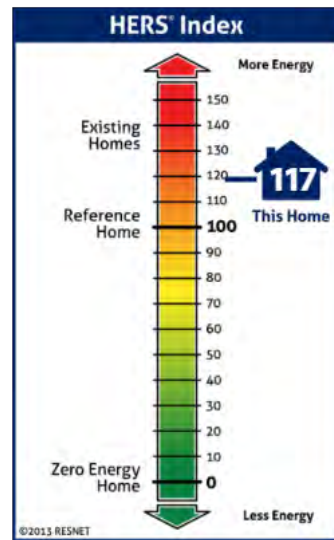

### Home Feature Summary:

Home Type:	Apartment, end unit
Model:	N/A
Community:	N/A
Conditioned Floor Area:	1,290 ft <sup>2</sup>
Number of Bedrooms:	3
Primary Heating System:	Air Source Heat Pump • Electric • 8.2 HSPF
Primary Cooling System:	Air Source Heat Pump • Electric • 14 SEER
Primary Water Heating:	Water Heater • Electric • 0.92 Energy Factor
House Tightness:	8.87 ACH50
Ventilation:	None
Duct Leakage to Outside:	1020 CFM @ 25Pa (79.05 / 100 s.f.)
Above Grade Walls:	R-19
Ceiling:	Attic, R-26
Window Type:	U-Value: 0.87, SHGC: 0.73
Foundation Walls:	N/A



# Home Energy Rating Certificate

## Projected Report

Rating Date:  
Registry ID:  
Ekotrope ID: bL7xj7Od

### HERS® Index Score:

# 77

Your home's HERS score is a relative performance score. The lower the number, the more energy efficient the home. To learn more, visit [www.hersindex.com](http://www.hersindex.com)

### Annual Savings

# \$670

\*Relative to an average U.S. home

**Home:**  
2150 Sinai Road  
South Boston, VA 24592

**Builder:**

### Your Home's Estimated Energy Use:

	Use [MBtu]
Heating	7.2
Cooling	2.3
Hot Water	7.8
Lights/Appliances	17.4
Service Charges	
Generation (e.g. Solar)	0.0
<b>Total:</b>	<b>34.7</b>

**This home meets or exceeds the criteria of the following:**

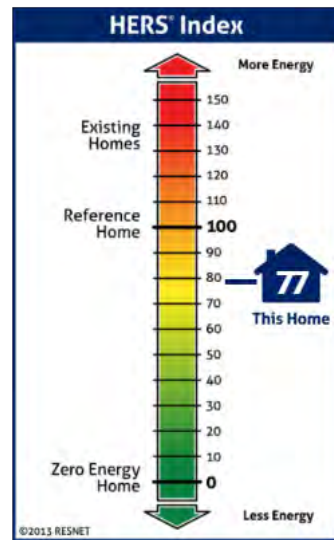

### Home Feature Summary:

Home Type:	Apartment, end unit
Model:	N/A
Community:	N/A
Conditioned Floor Area:	1,290 ft <sup>2</sup>
Number of Bedrooms:	3
Primary Heating System:	Air Source Heat Pump • Electric • 8.5 HSPF
Primary Cooling System:	Air Source Heat Pump • Electric • 16 SEER
Primary Water Heating:	Water Heater • Electric • 0.95 Energy Factor
House Tightness:	9 ACH50
Ventilation:	43.6 CFM • 116 Watts
Duct Leakage to Outside:	Untested
Above Grade Walls:	R-19
Ceiling:	Attic, R-49
Window Type:	U-Value: 0.3, SHGC: 0.25
Foundation Walls:	N/A

### Rating Completed by:

**Energy Rater:** Matt Waring  
RESNET ID: 6729287

**Rating Company:** Viridiant  
1431 W. Main Street, Richmond, VA 23220

**Rating Provider:** Viridiant  
1431 W. Main Street, Richmond, VA 23220

Matt Waring, Certified Energy Rater  
Date: 3/11/20 at 4:25 PM



G

Zoning Certification Letter  
(MANDATORY)

Town Planning Staff

Hope Cole  
Zoning Administrator



Department of Planning and Zoning  
455 Ferry Street  
South Boston, Virginia 24592  
(434)575-4241 phone (434)575-4275 fax

## Zoning Certification

**DATE:** February 3, 2020

**TO:** Virginia Housing Development Authority  
601 South Belvidere Street  
Richmond, Virginia 23220  
Attention: JD Bondurant

**RE:** ZONING CERTIFICATION

Name of Development: Westside Village Apartments

Name of Owner/Applicant: Westside Village Renewal LLC

Name of Seller/Current Owner: Westside Village Affordable LLC

The above-referenced Owner/Applicant has asked this office to complete this form letter regarding the zoning of the proposed Development (more fully described below). This certification is rendered solely for the purpose of confirming proper zoning for the site of the Development. It is understood that this letter will be used by the Virginia Housing Development Authority solely for the purpose of determining whether the Development qualifies for points available under VHDA's Qualified Allocation Plan for housing tax credits.

### DEVELOPMENT DESCRIPTION:

Development Address:

2150 Sinai Road

South Boston, VA 24592

Legal Description:

SEE ATTACHED

Proposed Improvements:

<input type="checkbox"/> New Construction:	_____ # Units	_____ # Buildings	_____ Approx. Total Floor Area Sq. Ft.
<input type="checkbox"/> Adaptive Reuse:	_____ # Units	_____ # Buildings	_____ Approx. Total Floor Area Sq. Ft.
<input checked="" type="checkbox"/> Rehabilitation:	<u>70</u> # Units	<u>18</u> # Buildings	<u>68,720</u> Approx. Total Floor Area Sq. Ft.

## Zoning Certification, cont'd

Current Zoning: R-4 (High Density Residential) allowing a density of

20 units per acre, and the following other applicable conditions:

### South Boston Town Code DIVISION 7. - SUPPLEMENTAL USE AND DESIGN STANDARDS

#### Sec. 114-176.4. - Multi-family dwelling.

The following standards shall apply to multifamily dwellings:

- (a) *Lot area* . The minimum lot required for a multifamily dwelling shall be 10,000 square feet.
- (b) *Density* .
  - (1) The maximum density for a multifamily dwelling in the R-4 zone shall be 20 dwelling units per acre.
- (c) *Lot frontage* . A multifamily dwelling shall have a minimum of 100 feet of frontage on a public street.
- (d) *Yard requirements* .
  - (1) Front yard: 25 feet
  - (2) Side yard: 20 feet
  - (3) Rear yard: 25 feet
  - (4) Where a side or rear yard abuts a single family dwelling, additional transitional yard buffer standards apply.
- (e) *Lot coverage* .
  - (1) The maximum lot coverage for a multifamily dwelling shall be 40 percent in the R-3 District;
  - (2) The maximum lot coverage for a multifamily dwelling shall be 50 percent in the R-4 District.
- (f) *Parking* .
  - (1) No off-street parking spaces or driveways shall be permitted between the public street and any principal building.
  - (2) Off-street parking spaces may be grouped in bays.
  - (3) Parking shall be provided and landscaped as required by other provisions of article V.
- (g) *Pedestrian access* . The townhouse development shall include a pedestrian circulation and access plan, including appropriate sidewalks, street crossings, pedestrian connections, trails, etc.
- (h) *Signs* . One ground-mounted sign is permitted for a multifamily development with eight or more units. The sign shall not exceed 20 square feet in size and shall be lighted using only ground-mounted and shielded, directed lighting fixtures.
- (i) *Required amenities* .
  - (1) Laundry facilities shall be provided within each dwelling unit or building.
  - (2) Common recreational facilities shall be provided for multifamily developments with 12 or more units. These may include such facilities as a playground, ball court, swimming pool, activity area, club house, gym, outdoor space or trail, or other similar use. Recreational facilities shall be located and operated to minimize impacts on adjacent properties with respect to noise, lighting, and hours of operation.
  - (3) Open space shall be provided for multifamily developments with 12 or more units. At least 20 percent of the lot area shall be dedicated to landscaped open space that can include required yards, but not parking, utility, or common facility areas.



## Zoning Certification, cont'd

- (4) Enclosed waste management facilities shall be provided for each multifamily dwelling building. All facilities shall be conveniently located, landscaped, and maintained. No such facility shall be located in any required yard or open space.
- (j) Property management offices may be permitted as an accessory use to a multifamily dwelling or development that contains 12 or more dwelling units. (Ord. of 2-10-14, § 2)

Height Limit: 45 feet

### Other Descriptive Information:

Built in 1977, Westside Village is a 70-unit, family low-income development consisting of 18 two-story brick buildings spread out on 7.996 acres. All 70 of the units are subsidized by project based Section 8 vouchers, featuring a broad unit mix of one, two, three and four bedroom units.

### LOCAL CERTIFICATION:

Check one of the following as appropriate:

- The zoning for the proposed development described above is proper for the proposed residential development. To the best of my knowledge, there are presently no zoning violations outstanding on this property. No further zoning approvals and/or special use permits are required.
- The development described above is an approved non-conforming use. To the best of my knowledge, there are presently no zoning violations outstanding on this property. No further zoning approvals and/or special use permits are required.

Hope Cole  
Signature

Hope Cole  
Printed Name

Zoning Administrator  
Title of Local Official or Civil Engineer

434-575-4241  
Phone:

2-3-2020  
Date:

### NOTES TO LOCALITY:

1. Return this certification to the developer for inclusion in the tax credit application package.
2. Any change in this form may result in disqualification of the application.
3. If you have any questions, please call the Tax Credit Allocation Department at (804) 343-5518.



# South Boston VIRGINIA

## Zoning Map

Adopted February 10, 2014

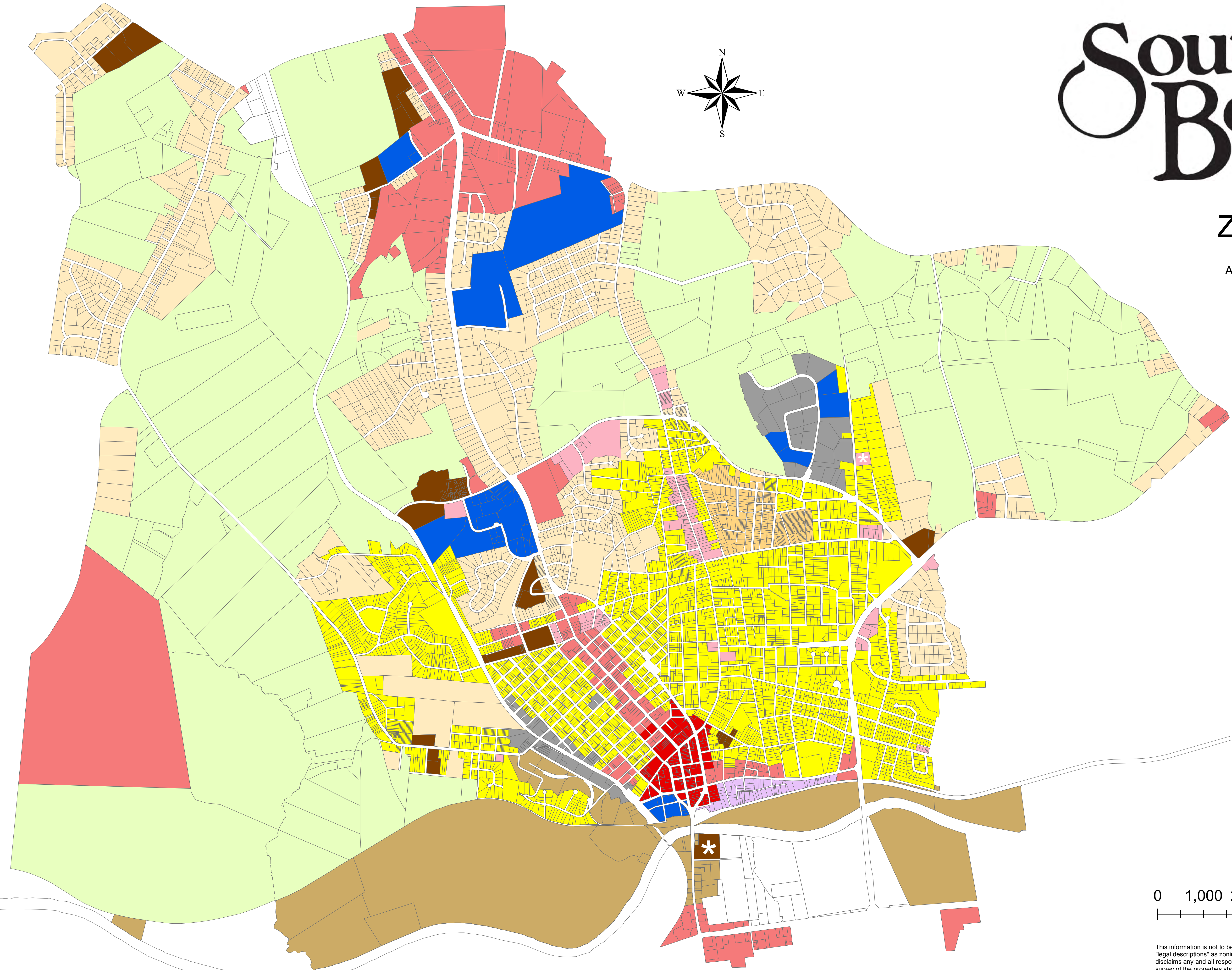
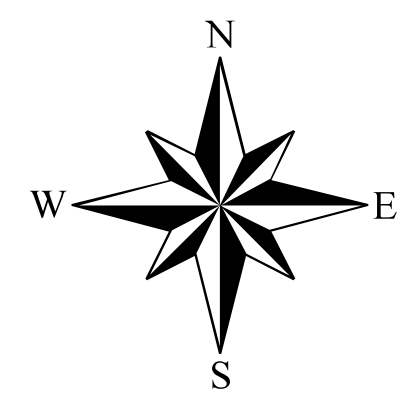

- B1
- B2
- B3
- B4
- DR
- EI
- M
- R1
- R2
- R3
- R4
- RAG

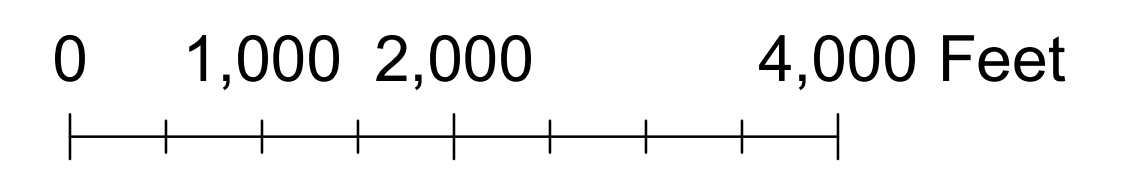

This information is not to be construed as a "land survey" and shall not be used to prepare "legal descriptions" as zoning is constantly changing. The Town of South Boston specifically disclaims any and all responsibility for errors, which may be disclosed by an accurate land survey of the properties shown herein. In no event shall the Town of South Boston be liable for any damages, direct or consequential, from the use of the information contained on this map. For the most up to date zoning information contact the Town of South Boston Planning Department at (434)575-4241.



# HALIFAX COUNTY BOARD OF SUPERVISORS

## PLANNING AND ZONING OFFICE

1030 Cowford Road, Suite LL1

P. O. BOX 699

HALIFAX, VIRGINIA 24558-0699

PHONE: (434) 476-3300 EXT. 3321

FAX: (434) 476-3384

[planning@co.halifax.va.us](mailto:planning@co.halifax.va.us)



Detrick Easley  
Zoning Administrator

## Zoning Certification

**DATE:** 2/18/2020

**TO:** Virginia Housing Development Authority  
601 South Belvidere Street  
Richmond, Virginia 23220  
Attention: JD Bondurant

**RE:** ZONING CERTIFICATION

Name of Development: Westside Village Apartments

Name of Owner/Applicant: Westside Village Renewal LLC

Name of Seller/Current Owner: Westside Village Affordable LLC

The above-referenced Owner/Applicant has asked this office to complete this form letter regarding the zoning of the proposed Development (more fully described below). This certification is rendered solely for the purpose of confirming proper zoning for the site of the Development. It is understood that this letter will be used by the Virginia Housing Development Authority solely for the purpose of determining whether the Development qualifies for points available under VHDA's Qualified Allocation Plan for housing tax credits.

### DEVELOPMENT DESCRIPTION:

Development Address:

2150 Sinai Road

South Boston, VA 24592

Legal Description:

SEE ATTACHED

---

---

---

---

---

---

---

Proposed Improvements:

<input type="checkbox"/> New Construction:	_____ # Units	_____ # Buildings	_____ Approx. Total Floor Area Sq. Ft.
<input type="checkbox"/> Adaptive Reuse:	_____ # Units	_____ # Buildings	_____ Approx. Total Floor Area Sq. Ft.
<input checked="" type="checkbox"/> Rehabilitation:	<u>70</u> # Units	<u>18</u> # Buildings	<u>68,720</u> Approx. Total Floor Area Sq. Ft.

## Zoning Certification, cont'd

### Other Descriptive Information:

Built in 1977, Westside Village is a 70-unit, family low-income development consisting of 18 two-story brick buildings spread out on 7.996 acres. All 70 of the units are subsidized by project based Section 8 vouchers, featuring a broad unit mix of one, two, three and four bedroom units.

### LOCAL CERTIFICATION:

The development described above falls under the jurisdiction of the Town of South Boston and not Halifax County. All Zoning related questions should be directed to the Planning and Zoning department there, under the direction of Ms. Hope Cole.

Detrick J. Easley  
Signature

Detrick Easley  
Printed Name

Planning + Zoning Administrator  
Title of Local Official or Civil Engineer

434 476-3300 ext. 3321  
Phone:

2-18-2020  
Date:





## **EXHIBIT A**

### **Legal Description of Property**

All that certain tract or parcel of land, with improvements and appurtenances thereunto belonging, lying and being situated in Banister District of Halifax County, Virginia, fronting 729.32 feet on the westerly boundary of Virginia State Highway No. 654, and described more particularly as follows:

Beginning at a new iron pipe in the westerly margin of the proposed Westside Drive, thence along the westerly margin of Virginia State Highway No. 654 S.  $50^{\circ} 48' 18''$  E 729.32 feet to an existing iron pipe in the westerly margin of Virginia State Highway No. 654 and the northern line of property now or formerly owned by James Martin; thence along the northern line of the Martin Property S.  $65^{\circ} 02' 50''$  W. 673.50 feet to a new iron pipe, a corner in Martin's northern line; thence leaving

Martin's northern line along a new line N.  $36^{\circ} 04' 25''$  W. 425.45 feet to a new iron; thence along a new line N.  $53^{\circ} 55' 35''$  E. 34.30 feet to a new iron pipe; thence along a new line N.  $15^{\circ} 46' 45''$  W. 159.93 feet to a new iron pipe in the southern margin of the proposed Westside Drive; thence along the southern margin of the proposed Westside Drive N.  $53^{\circ} 55' 35''$

E. 385.63 feet to a new iron pipe at the point of beginning, and containing 8 acres or 348.480 square feet.

H

Attorney's Opinion  
(MANDATORY)

March 12, 2020

Virginia Housing Development Authority  
601 South Belvidere Street  
Richmond, Virginia 23220-6500

RE: 2020 Tax Credit Reservation Request

Name of Development: Westside Village Apartments  
Name of Owner: Westside Village Renewal LLC

Gentlemen:

This undersigned firm represents the above-referenced Owner as its counsel. It has received a copy of and has reviewed the completed application package dated March 12, 2020 (of which this opinion is a part) (the "Application") submitted to you for the purpose of requesting, in connection with the captioned Development, a reservation of low income housing tax credits ("Credits") available under Section 42 of the Internal Revenue Code of 1986, as amended (the "Code"). It has also reviewed Section 42 of the Code, the regulations issued pursuant thereto and such other binding authority as it believes to be applicable to the issuance hereof (the regulations and binding authority hereinafter collectively referred to as the "Regulations").

Based upon the foregoing reviews and upon due investigation of such matters as it deems necessary in order to render this opinion, but without expressing any opinion as to either the reasonableness of the estimated or projected figures or the veracity or accuracy of the factual representations set forth in the Application, the undersigned is of the opinion that:

1. It is more likely than not that the inclusion in eligible basis of the Development of such cost items or portions thereof, as set forth in Parts VIII and IX of the Application form, complies with all applicable requirements of the Code and Regulations.
2. The calculations (a) of the Maximum Allowable Credit available under the Code with respect to the Development in Part VIII of the Application form and (b) of the Estimated Qualified Basis of each building in the Development comply in Part IX of the Application form with all applicable requirements of the Code and regulations, including the selection of credit type implicit in such calculations.
3. The appropriate type(s) of allocation(s) have been requested in the Reservation Request Information section in the Application form.
4. The information set forth in Subpart VII-C of the Application form as to proposed rents satisfies all applicable requirements of the Code and Regulations.

5. The site of the captioned Development is controlled by the Owner, as identified in Subpart II-A of the Application, for a period of not less than four (4) months beyond the application deadline.

6. The type of the nonprofit organization involved in the Development is an organization described in Code Section 501(c)(3) or 501(c)(4) and exempt from taxation under Code Section 501(a), whose purposes include the fostering of low-income housing.

7. The nonprofit organization's ownership interest in the development is as described in Subpart II-D of the Application form.

8. It is more likely than not that the representations made under Subpart I-F of the Application form as to the Development's compliance with or exception to the Code's minimum expenditure requirements for rehabilitation projects are correct.

9. After reasonable investigation, the undersigned has no reason to believe that the representations made under Subpart I-E of the Application form as to the Development's compliance with or eligibility for exception to the ten-year "look-back rule" requirement of Code Section 42(d)(2)(B) are not correct.

Finally, the undersigned is of the opinion that, if all information and representations contained in the Application and all current law were to remain unchanged, upon compliance by the Owner with the requirements of Code Section 42(h)(1)(E), the Owner would be eligible under the applicable provisions of the Code and the Regulations to an allocation of Credits in the amount(s) requested in the Application.

This opinion is rendered solely for the purpose of inducing the Virginia Housing Development Authority ("VHDA") to issue a reservation of Credits to the Owner. Accordingly, it may be relied upon only by VHDA and may not be relied upon by any other party for any other purpose.

**This opinion was not prepared in accordance with the requirements of Treasury Department Circular No. 230. Accordingly, it may not be relied upon for the purpose of avoiding U.S. Federal tax penalties or to support the promotion or marketing of the transaction or matters addressed herein.**

Bocarsly Emden Cowan Esmail & Arndt LLP

By:   
Craig A. Emden, Partner

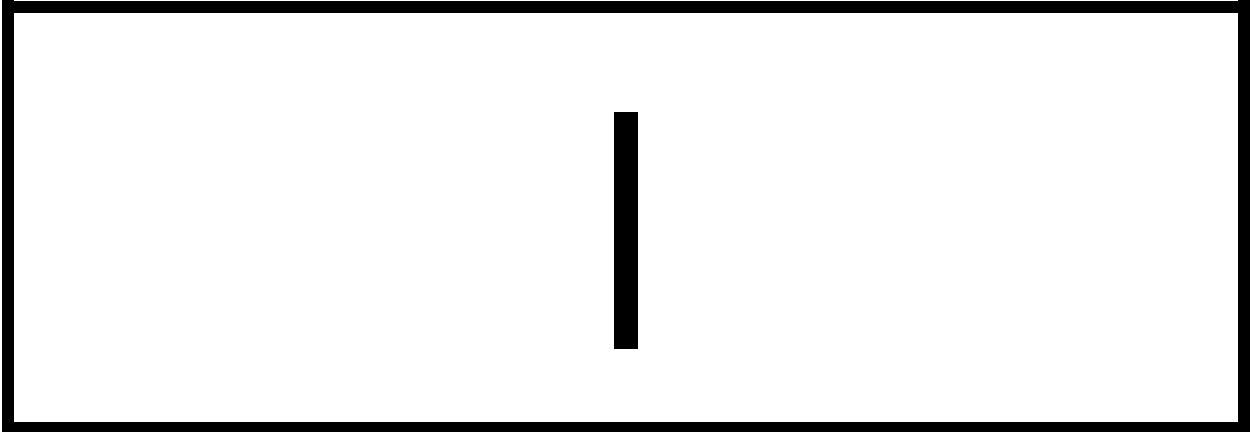

# Nonprofit Questionnaire

(MANDATORY for points or pool)



## Non-profit Questionnaire

Part II, 13VAC10-180-60, of the Qualified Allocation Plan (the "Plan") of the Virginia Housing Development Authority (the "Authority") for the allocation of federal low income housing tax credits ("Credits") available under §42 of the Internal Revenue Code, as amended (the "Code") establishes certain requirements for receiving credits from the non-profit pool established under the Plan and assigning points for participation of a non-profit organization in the development of qualified low-income housing.

Answers to the following questions will be used by the Authority in its evaluation of whether or not an applicant meets such requirements. Attach additional sheets as necessary to complete each question.

### 1. General Information

- a. Name of development: Westside Village Apartments
- b. Name of owner/applicant: Westside Village Renewal LLC
- c. Name of non-profit entity: Huntington Housing, Inc.
- d. Address of principal place of business of non-profit entity:  
11810 Grand Park Ave, Suite 600, North Bethesda, MD 20852

Indicate funding sources and amount used to pay for office space:  
See additional sheet

- e. Tax exempt status:  501(c)(3)  501(c)(4)  501(a)
- f. Date of legal formation of non-profit (must be prior to application deadline); \_\_\_\_\_  
evidenced by the following documentation: \_\_\_\_\_  
Articles of Incorporation dated June 2, 1994 (originally formed as Atlantic Housing, Inc.; name changed to  
Huntington Housing, Inc. ("Huntington") on December 18, 1997.)
- g. Date of IRS 501(c)(3) or 501(c)(4) determination letter (must be prior to application  
deadline and copy must be attached):  
January 17, 1995
- h. Describe exempt purposes (must include the fostering of low-income housing in its articles  
of incorporation):  
Work towards solutions to provide for the acquisition, development, rehabilitation, ownership, and operation of affordable housing  
for low- and moderate-income persons and families.
- i. Expected life (in years) of non-profit:  
Perpetual.

## Non-profit Questionnaire, cont'd

- j. Explain the anticipated future activities of the non-profit over the next five years:  
Please see additional sheet.  
\_\_\_\_\_  
\_\_\_\_\_  
\_\_\_\_\_
- k. How many full time, paid staff members does the non-profit and, if applicable, any other non-profit organization(s) ("related non-profit(s)") of which the non-profit is a subsidiary or to which the non-profit is otherwise related have (i.e. by shared directors, staff, etc.)?  
18 \_\_\_\_\_ How many part time, paid staff members? 0 \_\_\_\_\_
- Describe the duties of all staff members:  
Please see additional sheet for staff roster.  
\_\_\_\_\_  
\_\_\_\_\_  
\_\_\_\_\_
- l. Does the non-profit share staff with any other entity besides a related non-profit described above?  
 Yes  No If yes, explain in detail: \_\_\_\_\_  
\_\_\_\_\_  
\_\_\_\_\_
- m. How many volunteers does the non-profit and, if applicable, any related non-profit have?  
None  
\_\_\_\_\_  
\_\_\_\_\_
- n. What are the sources and manner of funding of the non-profit? (You must disclose all financial and/ or the arrangements with any individual(s) or for profit entity, including anyone or any entity related, directly, indirectly, to the Owner of the Development  
No outside funding. The Corporation's financial resources are derived from the net cash flow derived from the operation of affordable rental housing properties.  
\_\_\_\_\_  
\_\_\_\_\_  
\_\_\_\_\_
- o. List all directors of the non-profit, their occupations, their length of service on the board, and their residential addresses:  
Jason Goldblatt, Board Member since November 2010, CEO, NFAHS, Inc.  
7012 Arandale Rd., Bethesda, MD 20817  
Please see additional sheet.  
\_\_\_\_\_  
\_\_\_\_\_

## 2. Non-profit Formation

- a. Explain in detail the genesis of the formation of the non-profit:  
Please see additional sheet.  
\_\_\_\_\_  
\_\_\_\_\_  
\_\_\_\_\_

## Non-profit Questionnaire, cont'd

- b. Is the non-profit, or has it ever been, affiliated with or controlled by a for-profit entity or local housing authority?

Yes  No If yes, explain in detail:

---

---

---

- c. Has any for profit organization or local housing authority (including the Owner of the Development, joint venture partner, or any individual or entity directly or indirectly related to such Owner) appointed any directors to the governing board of the non-profit?

Yes  No If yes, explain:

---

---

---

- d. Does any for-profit organization or local housing authority have the right to make such appointments?

Yes  No If yes, explain:

---

---

- e. Does any for profit organization or local housing authority have any other affiliation with the non-profit or have any other relationship with the non-profit in which it exercises or has the right to exercise any other type of control?

Yes  No, If yes, explain:

---

---

- f. Was the non-profit formed by any individual(s) or for profit entity for the principal purpose of being included in the non-profit Pool or receiving points for non-profit participation under the Plan?

Yes  No

- g. Explain in detail the past experience of the non-profit including, if applicable, the past experience of any other related non-profit of which the non-profit is a subsidiary or to which the non-profit is otherwise related (by shared directors, staff, etc.):

Please see additional sheet.

---

---

---

- h. If you included in your answer to the previous question information concerning any related non-profit, describe the date of legal formation thereof, the date of IRS 501(c)(3) or 501(c)(4) status, its expected life, its charitable purposes and its relationship to the non-profit.

Please see additional sheet.

---

---

---

### 3. Non-profit Involvement



## Non-profit Questionnaire, cont'd

- a. Is the non-profit assured of owning an interest in the Development (either directly or through a wholly owned subsidiary) throughout the Compliance Period (as defined in §42(i)(1) of the Code)?

Yes  No

- (i) Will the non-profit own at least 10% of the general partnership/owning entity?  
 Yes  No
- (ii) Will the non-profit own 100% of the general partnership interest/owning entity?  
 Yes  No

If no to either 3a.i or 3a.ii above, specifically describe the non-profit's ownership interest:

---

---

- b. (i) Will the non-profit be the managing member or managing general partner?  
 Yes  No If yes, where in the partnership/operating agreement is this provision specifically referenced?

In section 3.1 of the Operating Agreement.

---

---

- (ii) Will the non-profit be the managing member or own more than 50% of the general partnership interest?  Yes  No

- c. Will the non-profit have the option or right of first refusal to purchase the proposed development at the end of the compliance period for a price not to exceed the outstanding debt and exit taxes of the for-profit entity?

Yes  No If yes, where in the partnership/operating agreement is this provision specifically referenced?

It will be contained in a purchase option and right of first refusal agreement.

---

---

Recordable agreement attached to the Tax Credit Application as TAB V

If no at the end of the compliance period explain how the disposition of the assets will be structured:

---

---

- d. Is the non-profit materially participating (regular, continuous, and substantial participation) in the construction or rehabilitation and operation or management of the proposed Development?

Yes  No If yes,

- (i) Describe the nature and extent of the non-profit's proposed involvement in the construction or rehabilitation of the Development:

Please see additional sheet.

---

---

- (ii) Describe the nature and extent of the non-profit's involvement in the operation or

## Non-profit Questionnaire, cont'd

management of the Development throughout the Extended Use Period (the entire time period of occupancy restrictions of the low-income units in the Development):

Please see additional sheet.

---

---

---

- (iii) Will the non-profit invest in its overall interaction with the development more than 500 hours annually to this venture?  Yes  No If yes, subdivide the annual hours by activity and staff responsible and explain in detail:

Please see additional sheet.

---

---

---

- e. Explain how the idea for the proposed development was conceived. For example, was it in response to a need identified by a local neighborhood group? Local government? Board member? Housing needs study? Third party consultant? Other?

Huntington is committed to preserving our nation's existing affordable housing stock. During discussions with a third party

consultant and state/local officials about the need for preservation of affordable housing properties in the local community, we

decided to get involved with the preservation of Westside Village Apartments.

---

---

---

- f. List all general partners/managing members of the Owner of the Development (one must be the non-profit) and the relative percentages of their interests:

See attached organizational chart (Tab A).

---

---

---

- g. If this is a joint venture, (i.e. the non-profit is not the sole general partner/managing member), explain the nature and extent of the joint venture partner's involvement in the construction or rehabilitation and operation or management of the proposed development.

N/A

---

---

---

- h. Is a for profit entity providing development services (excluding architectural, engineering, legal, and accounting services) to the proposed development?  Yes  No If yes, (i) explain the nature and extent of the consultant's involvement in the construction or rehabilitation and operation or management of the proposed development.

Chesapeake Community Advisors (CCA) will act as a contractor to Huntington. CCA will provide additional staffing to assist

Huntington during the application process.

---

---

---

- (ii) Explain how this relationship was established. For example, did the non-profit solicit proposals from several for-profits? Did the for-profit contact the non-profit and offer the services?

CCA and Huntington have worked together for many years. Huntington asked CCA to serve as a consultant to help prepare the LIHTC application.

---

---

---

- i. Will the non-profit or the Owner (as identified in the application) pay a joint venture partner

## Non-profit Questionnaire, cont'd

or consultant fee for providing development services?  Yes  No If yes, explain the amount and source of the funds for such payments.

Huntington will use its working capital to pay CCA \$10,000 for assistance with the LIHTC application.

---

---

---

- j. Will any portion of the developer's fee which the non-profit expects to collect from its participation in the development be used to pay any consultant fee or any other fee to a third party entity or joint venture partner?  Yes  No If yes, explain in detail the amount and timing of such payments.
- 
- 
- 

- k. Will the joint venture partner or for-profit consultant be compensated (receive income) in any other manner, such as builder's profit, architectural and engineering fees, or cash flow?  Yes  No If yes, explain:
- 
- 
- 

- l. Will any member of the board of directors, officer, or staff member of the non-profit participate in the development and/or operation of the proposed development in any for-profit capacity?  Yes  No If yes, explain:
- 
- 
- 

- m. Disclose any business or personal (including family) relationships that any of the staff members, directors or other principals involved in the formation or operation of the non-profit have, either directly or indirectly, with any persons or entities involved or to be involved in the Development on a for-profit basis including, but not limited to the Owner of the Development, any of its for-profit general partners, employees, limited partners or any other parties directly or indirectly related to such Owner:

None

---

---

---

- n. Is the non-profit involving any local, community based non-profit organizations in the development, role and operation, or provision of services for the development?  Yes  No If yes, explain in detail, including the compensation for the other non-profits:
- 
- 
-

## Non-profit Questionnaire, cont'd

### 4. Virginia and Community Activity

a. Has the Virginia State Corporation Commission authorized the non-profit to do business in Virginia?  Yes  No

b. Define the non-profit's geographic target area or population to be served:

Please see additional sheet.

---

---

c. Does the non-profit or, if applicable, related non-profit have experience serving the community where the proposed development is located (including advocacy, organizing, development, management, or facilitation, but not limited to housing initiatives)?

Yes  No If yes, or no, explain nature, extent and duration of any service:

Please see additional sheet for details.

---

---

d. Does the non-profit's by laws or board resolutions provide a formal process for low income, program beneficiaries to advise the non-profit on design, location of sites, development and management of affordable housing?  Yes  No If yes, explain:

---

---

---

e. Has the Virginia Department of Agriculture and Consumer Services (Division of Consumer Affairs) authorized the non-profit to solicit contributions/donations in the target community?

Yes  No

f. Does the non-profit have demonstrated support (preferably financial) from established organizations, institutions, businesses and individuals in the target community?

Yes  No If yes, explain:

We have received verbal support and have received a general letter of support from the Town Manager of South Boston and

County Administrator of Halifax County. Huntington received similar support for its other projects in Southern Virginia

(Settlers Point, Springdale Village, Burton Creek and Northwinds).

---

---

g. Has the non-profit conducted any meetings with neighborhood, civic, or community groups and/or tenant associations to discuss the proposed development and solicit input?  Yes  No If yes, describe the meeting dates, meeting locations, number of attendees and general discussion points:

Huntington plans to schedule meetings with residents of Westside Village if the project receives an allocation of LIHTCs. The non-profit in conjunction with on-site management will explain the construction timeline, temporary relocation, and answer questions/concerns of residents.

---

---

h. Are at least 33% of the members of the board of directors representatives of the community being served?  Yes  No If yes,

(i) low-income residents of the community?  Yes  No

## Non-profit Questionnaire, cont'd

- (ii) elected representatives of low-income neighborhood organizations?  Yes  No
- i. Are no more than 33% of the members of the board of directors representatives of the public sector (i.e. public officials or employees or those appointed to the board by public officials)?  Yes  No
- j. Does the board of directors hold regular meetings which are well attended and accessible to the target community?  Yes  No If yes, explain the meeting schedule:  
Huntington's board meets annually or otherwise, advises its members through its officers and makes decisions via unanimous written consent based on advice from its investment committee.
- k. Has the non-profit received a Community Housing Development Organization (CHDO) designation, as defined by the U. S. Department of Housing and Urban Development's HOME regulations, from the state or a local participating jurisdiction?  Yes  No
- l. Has the non-profit been awarded state or local funds for the purpose of supporting overhead and operating expenses?  Yes  No If yes, explain in detail:
- m. Has the non-profit been formally designated by the local government as the principal community-based non-profit housing development organization for the selected target area?  Yes  No If yes, explain:
- n. Has the non-profit ever applied for Low Income Housing Tax Credits for a development in which it acted as a joint venture partner with a for-profit entity?  Yes  No If yes, note each such application including: the development name and location, the date of application, the non-profit's role and ownership status in the development, the name and principals of the joint venture partners, the name and principals of the general contractor, the name and principals of the management entity, the result of the application, and the current status of the development(s).
- o. Has the non-profit ever applied for Low Income Housing Tax Credits for a development in which it acted as the sole general partner/managing member?  Yes  No If yes, note each such development including the name and location, the date of the application, the result of the application, and the current status of the development(s).  
Springdale Village Apartments, Bristol, VA, 2011 Credits Awarded, Complete  
Settlers Point Apartments, Damascus, VA, 2011 Credits Awarded, Complete  
Northwinds Apartments, Wytheville, VA, 2013, Credits Awarded, Complete  
Burton Creek Apartments, Lynchburg, VA, 2018, Credits Awarded, Under Construction
- p. To the best of your knowledge, has this development, or a similar development on the same site, ever received tax credits before?  Yes  No If yes, explain:

**Non-profit Questionnaire, cont'd**

q. Has the non-profit been an owner or applicant for a development that has received a reservation in a previous application round from the Virginia Housing Partnership or the VHDA Housing Funds?  Yes  No If yes, explain:

r. Has the non-profit completed a community needs assessment that is no more than three years old and that, at a minimum identifies all of the defined target area's housing needs and resources?  Yes  No If yes, explain the need identified:

s. Has the non-profit completed a community plan that (1) outlines a comprehensive strategy for addressing identified community housing needs, (2) offers a detailed work plan and timeline for implementing the strategy, and (3) documents that the needs assessment and comprehensive strategy were developed with the maximum possible input from the target community?  Yes  No If yes, explain the plan:

**5. Attachments**

Documentation of any of the above need not be submitted unless requested by VHDA

The undersigned Owner and non-profit hereby each certify that, to the best of its knowledge, all of the foregoing information is complete and accurate. Furthermore, each certifies that no attempt has been or will be made to circumvent the requirements for non-profit participation contained in the Plan or Section 42 of the Internal Revenue Code.

3/6/2020  
Date

Westside Village Renewal LLC  
Owner/Applicant  
By: [Signature]  
Its: President  
Title

3/6/2020  
Date

Huntington Housing, Inc.  
Non-profit  
By: [Signature]  
Board Chairman

**Non-profit Questionnaire, cont'd**

By:  \_\_\_\_\_  
Executive Director





## VHDA Non-Profit Questionnaire Additional Sheet

1.

- d. No funding sources; utilize office space as a supporting organization of the National Foundation for Affordable Housing Solutions, Inc. (the "Foundation").
- j. Continue to participate in the ownership of existing affordable housing assets, and seek opportunities to expand ownership participation in new affordable housing assets in accordance with the mission to own, operate, rehabilitate and preserve affordable housing for low-income families and senior citizens in Virginia and elsewhere.
- k.
  - 1) Jason Goldblatt – Chairman and Chief Executive Officer - Acts as chief executive officer, responsible for recommendation and execution of board directives.
  - 2) Todd Travis – President and Chief Operating Officer – Acts as chief operating officer, handles day to day operations including development, asset management, and compliance.
  - 3) Randy Kelly – Vice President and General Counsel – Oversees all aspects of the Foundation's legal matters
  - 4) Janet Charlton – Executive Vice President - Assist with compliance on existing properties; lead policy and education initiatives
  - 5) John Parreco – Director of Acquisitions – Identifies acquisition opportunities, conducts due diligence, and finalizes new property acquisitions
  - 6) Rosann Redmon – Comptroller – Handles corporate accounting
  - 7) Bobby Custer – Director of Asset Management – Manages property-level asset management
  - 8) Lauren Scully – Senior Asset Manager - Property-level asset management 9) Amanda Kryz – Asset Manager
  - 10) Alex Weldon – Asset Manager - Property-level asset management
  - 11) Dominick Bonomolo - Asset Manager - Property-level asset management
  - 12) Jay Haynes – Asset Manager/Development - Property-level asset management
  - 13) Christina Schmiedel – Tax Analyst – Handles corporate and entity tax aspects 14) Cassandra Palanza – Director of Special Projects – Oversees all aspects of special projects at the Foundation including development.
  - 15) Janis Butler – Executive Assistant – Provides assistance to Mr. Travis
  - 16) Tracy Phillips – Executive Assistant – Provides assistance to Mr. Goldblatt
  - 17) Luciano Sangalang – Office Services Assistant – Assists office staff in various matters
  - 18) Jeff Cordisco – Director of Construction – oversees construction and development.

2.

- a. Huntington was formed by the Foundation exclusively to support the Foundation's charitable mission to work toward solutions to provide for the acquisition, development, rehabilitation, ownership and operation of affordable housing for low and moderate income persons and families. Huntington supports this mission by acting as the managing member of single-purpose entities which operate affordable rental housing properties.

- g.** Huntington is currently the managing member of 4 low income housing properties located in Virginia which total 425 low income housing tax credit (“LIHTC”) units. Similar organizations which support the Foundation own over 11,000 affordable units across in 21 states throughout the country. Approximately, 30 of these properties benefit from LIHTCs, The Foundation provides support in the form of human and financial capital to its supporting organizations in furtherance of their shared charitable purpose.
- h.** The Foundation was formed on January 11, 1990, and its IRS determination letter was issued on June 6, 1990. The Foundation’s charitable purpose is to engage in activities that will assist in the provision of decent affordable housing for low and moderate income persons and families, working towards solutions to provide for the acquisition, rehabilitation, development, ownership and operation of affordable housing. The Foundation sponsored the formation of Huntington Housing, Inc. and the Foundation lends human resources and financial capital to Huntington in support of their shared charitable mission.

**3.**

- d. i)** As sole member of the managing member, Huntington is the Owner’s representative supervising the construction and rehabilitation of the project. The Owner works collaboratively with its construction manager and contractor to accomplish the construction and rehabilitation of the proposed Development.
- ii)** As sole member of the managing member, Huntington is principally responsible for the operation of the property and compliance with all regulatory requirements and tax credit compliance. Huntington works directly with its property manager to oversee the management of the property and to optimize operational efficiencies at the Development.
- iii)** It is expected that the Huntington staff will spend at least 10 hours a week on a going forward basis on the construction, rehabilitation, operation, maintenance and management of the Development, including hours dedicated to construction oversight, property management oversight, legal oversight and regulatory compliance for the property.

**4.**

- b.** Huntington owns projects in the Mid-Atlantic (DE-VA) including 4 LIHTC properties in Virginia. Huntington has successfully developed three LIHTC properties in Southwest, VA (Settlers Point, Springdale Village, and Northwinds Apartments), and construction is in process on the 4<sup>th</sup> property, Burton Creek. Huntington is actively endeavoring to acquire additional affordable properties in southern and central Virginia.
- c.** Huntington is the managing member of Settlers Point Affordable LLC, Springdale Affordable LLC, Northwinds Renewal LLC and Burton Creek Renewal LLC, four low income housing tax credit properties in southern VA. Huntington has successfully organized, developed, and managed the rehabilitation of these projects. In addition, Westside Village in South Boston is currently owned by an entity controlled by the Foundation.



ARTICLES OF INCORPORATION  
OF  
ATLANTIC HOUSING, INC.

APPROVED AND RECEIVED FOR RECORD BY THE STATE DEPARTMENT OF ASSESSMENTS AND TAXATION  
OF MARYLAND JUNE 2, 1994 AT 9:00 O'CLOCK A. M. AS IN CONFORMITY  
WITH LAW AND ORDERED RECORDED.

ORGANIZATION AND CAPITALIZATION FEE PAID \$ 20.00  
RECORDING FEE PAID \$ 20.00  
SPECIAL FEE PAID \$

D3901683

XX

IT IS HEREBY CERTIFIED, THAT THE WITHIN INSTRUMENT, TOGETHER WITH ALL ENDORSEMENTS THEREON, HAS  
BEEN RECEIVED, APPROVED AND RECORDED BY THE STATE DEPARTMENT OF ASSESSMENTS AND TAXATION OF MARYLAND.

NANCY J. TRICK  
11200 ROCKVILLE PIKE  
ROCKVILLE MD 20852

23503074566

A 455850

RECORDED IN THE RECORDS OF THE  
STATE DEPARTMENT OF ASSESSMENTS  
AND TAXATION OF MARYLAND IN LIBER. 1010



STATE OF MARYLAND

I hereby certify that this is a true and complete copy of the page document on file in this office. DATED: \_\_\_\_\_

STATE DEPARTMENT OF ASSESSMENTS AND TAXATION

BY: \_\_\_\_\_, Custodian

This stamp replaces our previous certification system. Effective: 6/95

**ARTICLES OF INCORPORATION**

**OF**

**ATLANTIC HOUSING, INC.**

6-2-94

9:00 a.

The undersigned, Nancy Jeanne Trick, whose address is 112 Kendrick Place, Gaithersburg, Maryland 20878, being at least eighteen (18) years of age, does hereby form a nonstock corporation under and by virtue of the General Laws of the State of Maryland.

**FIRST.** The name of the corporation is Atlantic Housing, Inc. (hereinafter, the "Corporation").

**SECOND.** The period of its duration shall be perpetual.

**THIRD.** The Corporation is organized and shall be operated exclusively for charitable and educational purposes by conducting or supporting activities for the benefit of or to carry out the purposes of The National Foundation for Affordable Housing Solutions, Inc. (the "Foundation") which is a charitable and educational organization that is exempt from federal income tax under Section 501(c)(3) of the Internal Revenue Code of 1986, as amended (the "Code") and which is not a private foundation under Section 509(a)(1).

The Corporation shall work toward solutions to provide for the acquisition, development, rehabilitation, ownership and operation of affordable housing for low- and moderate-income persons and families. It will accomplish these purposes by the acquisition, development, management, asset management, provision of services and/or financing of decent, affordable housing for low- and moderate-income persons. Through such activities, the Corporation will promote the revitalization of neighborhoods, will seek to improve the quality of economic and social participation in community life so as to eliminate poverty and will seek to provide permanent economic and social benefits for low- and moderate-income persons and families.

11538232

Notwithstanding the above, if the Foundation ceases to be an organization described in Section 501(c)(3) and Sections 509(a)(1) or (a)(2) of the Code, the Corporation shall cease to operate for the benefit of or in connection with said organization, but shall be operated for the benefit of and in connection with such other organization or organizations which are (i) described in Section 501(c)(3) and Sections 509(a)(1) or (a)(2) of the Code and (ii) organized and operated for the purposes similar to those of the Foundation as the Board of Directors of the Corporation shall determine.

No part of the income or principal of the Corporation shall inure to the benefit of any director or officer of this Corporation or any other private individual, except that the Corporation shall be authorized and empowered to pay reasonable compensation for services actually rendered to it, and to make reasonable payments and distributions in furtherance of the aforementioned purposes of the Corporation. The Corporation shall not engage in any activity which is prohibited to a corporation exempt from federal income tax under Section 501(c)(3) of the Code or any corresponding future provision of the federal tax law. In accordance with the existing federal tax law, the Corporation shall not participate or intervene in any political campaign on behalf of any candidate for public office by publishing or distributing statements, or any other way. No substantial part of the activities of the Corporation shall be the carrying on of propaganda, or otherwise attempting to influence legislation.

It is intended that this Corporation shall have the status of a corporation which is exempt from federal income taxation under Section 501(a) of the Code as an organization described in Section 501(c)(3) of the Code, and which is other than a private foundation under Section 509(a)(3) of the Code. These articles shall be construed accordingly, and all powers and activities of the Corporation shall be limited accordingly.

**FOURTH:** The Corporation shall not have members.

**FIFTH:** The Corporation shall not be authorized to issue capital stock.

**SIXTH:** The names of the two persons who shall serve as the initial directors of the Corporation are Jason Berman and Tony Coelho. The Board of Directors shall be appointed or elected by the Board of Directors of the Foundation, or by such officers of the Foundation, acting in their official capacity, as the Board of Directors of the Foundation has so designated.

**SIXTH:** Provisions for the distribution of assets on dissolution or the termination of the Corporation are as follows:

Although the period of duration of the Corporation is perpetual, if for any reason the Corporation is to be dissolved or otherwise terminated, no part of the property of the Corporation or any of the proceeds shall be distributed to or inure to the benefit of any of the directors of the Corporation. In such event, all property and proceeds of the Corporation, subject to the discharge of valid obligations of the Corporation, and to the applicable provisions of the General Laws of the State of Maryland, shall be distributed to the Foundation or its successor, if any, unless the Foundation shall not then be in existence or shall not be a qualified Section 501(c)(3) and Section 509(a)(1) or (a)(2) organization, in which case the assets of the Corporation shall be distributed as directed by the Board of Directors to one or more Section 501(c)(3) and Section 509(a)(1) or (a)(2) organizations, exclusively for one or more exempt purposes within the meaning of Section 501(c)(3) of the Code, or any corresponding future provision of the federal tax law. Any of such assets not so disposed of shall be disposed of by the Circuit Court of Montgomery County, or such other court sitting in equity of the political subdivision in which the principal office of the Corporation is then located, exclusively for one or more exempt purposes within the meaning of Section 501(c)(3) of the Code, or any corresponding future provision of the federal tax law, as said court shall determine.

**SEVENTH:** The present address of the principal office of the Corporation in Maryland is 11200 Rockville Pike, Rockville, Maryland 20852. The name and address, including street and number of its initial resident agent is Martin C. Schwartzberg, 11200 Rockville Pike, Rockville, Maryland 20852. The resident agent is a citizen of Maryland residing therein.

**EIGHT:** The directors and officers of the Corporation shall have not liability to the Corporation for money damages except (i) to the extent that it is proven that such person actually received an improper benefit or profit in money, property or services or (ii) to

the extent that a judgment or other final adjudication adverse to such person is entered in a proceeding based on a finding in the proceeding that the person's action, or failure to act, was the result of active and deliberate dishonesty and was material to the case of action adjudicated in the proceeding. This Article shall not be construed to affect the liability of a person in any capacity other than as a director or officer of the Corporation.

IN WITNESS WHEREOF, I have signed these Articles and acknowledge the same to be my act on this 1st day of June, 1994.

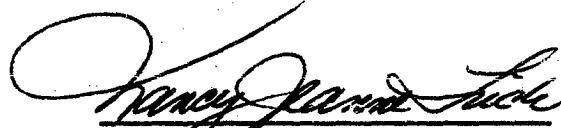

Nancy Jeanne Trick  
Nancy Jeanne Trick  
Incorporator



ARTICLES OF AMENDMENT  
TO  
ARTICLES OF INCORPORATION  
OF  
ATLANTIC HOUSING, INC.

RECEIVED FOR RECORD  
12/18/97 at 9:36 AM

Pursuant to the General Laws of the State of Maryland, Atlantic Housing, Inc. ("Corporation") hereby certifies to the State Department of Assessments and Taxation of Maryland that the Articles of Incorporation ("Articles") of the Corporation are hereby amended as follows:

WHEREAS, the Corporation wishes to change its name;

NOW, THEREFORE, BE IT RESOLVED, that Article First of the Corporation's Articles is amended to read as follows:

"FIRST: The name of the Corporation (hereinafter "Corporation") is Huntington Housing, Inc."

This amendment of the Articles of the Corporation has been approved by the Board of Directors. There is no membership.

We, the undersigned President and Secretary swear under penalties of perjury that the foregoing is a corporate act.

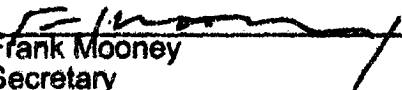
  
Frank Mooney  
Secretary

  
Anthony Coelho  
President

RECEIVED  
97 DEC 18 AM 9 36  
ASSESS. & TAX.

I.D. NO# D3901693  
ACKY. NO. - 120C3118752  
HUNTINGTON HOUSING, INC.

12/18/97 AT 09:36 A.M.

STATE OF MARYLAND

I hereby certify that this is a true and complete copy of the page document on file in this office. DATED: 

STATE DEPARTMENT OF ASSESSMENTS AND TAXATION:

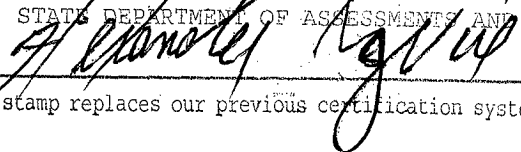
BY: , Custodian

This stamp replaces our previous certification system. Effective: 6/95

State of Maryland  
**DEPARTMENT OF  
 ASSESSMENTS AND TAXATION**



FARRIS N. GLENNING  
 Governor  
 RONALD W. WENZELT  
 Director  
 PAUL B. ANDERSON  
 Administrator

Charter Division

DOCUMENT CODE 09A BUSINESS CODE \_\_\_\_\_ COUNTY 65  
 # D3901683 P.A. \_\_\_\_\_ Religious \_\_\_\_\_ Close \_\_\_\_\_ Stock \_\_\_\_\_ Nonstock

Merging (Transferor) \_\_\_\_\_ Surviving (Transferee) \_\_\_\_\_  
 \_\_\_\_\_  
 \_\_\_\_\_

**CODE AMOUNT FEE REMITTED**

10 \_\_\_\_\_ Expedited Fee  
 61 \_\_\_\_\_ Rec. Fee (Arts. of Inc.)  
 20 \_\_\_\_\_ Organ. & Capitalization  
 62 20 Rec. Fee (Amendment)  
 63 \_\_\_\_\_ Rec. Fee (Merger, Consol.)  
 64 \_\_\_\_\_ Rec. Fee (Transfer)  
 66 \_\_\_\_\_ Rec. Fee (Revival)  
 65 \_\_\_\_\_ Rec. Fee (Dissolution)  
 75 \_\_\_\_\_ Special Fee  
 73 \_\_\_\_\_ Certificate of Conveyance

---

21 \_\_\_\_\_ Recordation Tax  
 22 \_\_\_\_\_ State Transfer Tax  
 23 \_\_\_\_\_ Local Transfer Tax  
 70 \_\_\_\_\_ Change of P.O., R.A. or R.A.A.  
 31 \_\_\_\_\_ Corp. Good Standing

(New Name) HUNTINGTON  
 HOUSING, INC.

- Change of Name
- Change of Principal Office
- Change of Resident Agent
- Change of Resident Agent Address
- Resignation of Resident Agent
- Designation of Resident Agent and Resident Agent's Address
- Change of Business Code
- Adoption of Assumed Name
- Other Change(s) \_\_\_\_\_

**600 Returns**

52 \_\_\_\_\_ Foreign Qualification  
 NA \_\_\_\_\_ Foreign Registration  
 51 \_\_\_\_\_ Foreign Name Registration  
 53 \_\_\_\_\_ Foreign Resolution  
 54 \_\_\_\_\_ For. Supplemental Cert.  
 56 \_\_\_\_\_ Penalty  
 50 \_\_\_\_\_ Cert. of Qual. or Reg.  
 83 \_\_\_\_\_ Cert. Limited Partnership  
 84 \_\_\_\_\_ Amendment to Limited Partnership  
 85 \_\_\_\_\_ Termination of Limited Partnership  
 80 \_\_\_\_\_ For. Limited Partnership  
 91 \_\_\_\_\_ Amend/Cancellation, For. Limited Part.  
 87 \_\_\_\_\_ Limited Part. Good Standing  
 67 \_\_\_\_\_ Cert. Limited Liability Partnership  
 68 \_\_\_\_\_ LLP Amendment - Domestic  
 69 \_\_\_\_\_ Foreign Limited Liability Partnership  
 74 \_\_\_\_\_ LLP Amendment - Foreign  
 99 \_\_\_\_\_ Art. of Organization (LLC)  
 98 \_\_\_\_\_ LLC Amend, Diss, Continuation  
 97 \_\_\_\_\_ LLC Cancellation  
 96 \_\_\_\_\_ Registration Foreign LLC  
 94 \_\_\_\_\_ Foreign LLC Supplemental  
 92 \_\_\_\_\_ LLC Good Standing (short)  
 13 \_\_\_\_\_ Certified Copy  
 \_\_\_\_\_ Other \_\_\_\_\_

CODE \_\_\_\_\_  
 ATTENTION: \_\_\_\_\_  
 \_\_\_\_\_

MAIL TO ADDRESS:  
National Foundation for  
Affordable Housing  
W. Putnam Inc. X 300 50  
11200 Rockville Pk  
Rockville, MD

NOTE: 2082

TOTAL FEES 20 Credit Card \_\_\_\_\_  
 Check  Cash \_\_\_\_\_

Documents on \_\_\_\_\_ checks \_\_\_\_\_  
 APPROVED BY: WMA



12-15-87 11:53AM

99 9/120223791317 37 2006/000

Internal Revenue Service

Department of the Treasury

Washington, DC 20224

Person to Contact: L.E. Kawecki

Atlantic Housing, Inc.  
c/o National Foundation for Affordable  
Housing Solutions, Inc.  
11200 Rockville Pike, 4th floor  
Rockville, MD 20852

Telephone Number: (202) 622-7728

Refer Reply to: CP:E:EO:T:5

Date: JAN 17 1995

Employer Identification Number: 52-1879282  
Key District: Baltimore  
Accounting Period Ending: December 31  
Foundation Status Classification: 509(a)(3)  
Form 990 Required: Yes

Dear Applicant:

Based on the information supplied, and assuming your operations will be as stated in your application for recognition of exemption, we have determined you are exempt from federal income tax under section 501(a) of the Internal Revenue Code as an organization described in section 501(c)(3).

We have further determined that you are not a private foundation within the meaning of section 509(a) of the Code, because you are an organization described in the section(s) indicated above.

If your sources of support, or your purposes, character, or method of operation change, please let your key district know so that office can consider the effect of the change on your exempt status. In the case of an amendment to your organizational document or bylaws, please send a copy of the amended document or bylaws to your key district. Also, you should inform your key district office of all changes in your name or address.

As of January 1, 1984, you are liable for taxes under the Federal Insurance Contributions Act (social security taxes) on remuneration of \$100 or more you pay to each of your employees during a calendar year. This does not apply, however, if you make or have made a timely election under section 3121(w) of the Code to be exempt from such tax. You are not liable for the tax imposed under the Federal Unemployment Tax Act.

Since you are not a private foundation, you are not subject to the excise taxes under Chapter 42 of the Code. However, you are not automatically exempt from other federal excise taxes. If you have any questions about excise, employment, or other federal taxes, please contact your key district office.

Atlantic Housing, Inc.

Donors may deduct contributions to you as provided in section 170 of the Code. Bequests, legacies, devises, transfers, or gifts to you or for your use are deductible for federal estate and gift tax purposes if they meet the applicable provisions of Code sections 2055, 2106, and 2522.

Donors (including private foundations) may rely on this ruling unless the Internal Revenue Service publishes notice to the contrary. However, if you lose your 509(a) status as indicated above, donors (other than private foundations) may not rely on the classification indicated above if they were in part responsible for, or were aware of, the act that resulted in your loss of such status, or they acquired knowledge that the Internal Revenue Service had given notice that you would be removed from that classification. Private foundations may rely on the classification as long as you were not directly or indirectly controlled by them or by disqualified persons with respect to them. However, private foundations may not rely on the classification indicated above if they acquired knowledge that the Internal Revenue Service had given notice that you would be removed from that classification.

Contribution deductions are allowable to donors only to the extent that their contributions are gifts, with no consideration received. Ticket purchases and similar payments in conjunction with fundraising events may not necessarily qualify as fully deductible contributions, depending on the circumstances. If your organization conducts fund-raising events such as benefit dinners, shows, membership drives, etc., where something of value is received in return for payments, you can help your contributors avoid difficulties with their income tax returns by assisting them in determining the proper tax treatment of their contributions. To do this you should, in advance of the event, determine the fair market value of the benefit received and state it in your fund-raising materials such as solicitations, tickets, and receipts in such a way that they can determine how much is deductible and how much is not. To assist you in this, the Service has issued Publication 1391, Deductibility of Payments Made to Organizations Conducting Fund-Raising Events. You may obtain copies of Publication 1391 from your key district office.

You are not required to file federal income tax returns unless you are subject to the tax on unrelated business income under section 511 of the Code. If you are subject to this tax, you must file an income tax return on Form 990-T, Exempt Organization Business Income Tax Return. In this letter we are not determining whether any of your present or proposed activities are unrelated trade or business as defined in section 513 of the Code.

Atlantic Housing, Inc.

You are required to make a copy of your exemption application, and supporting documents, and this exemption letter available for public inspection. Failure to make these documents available for public inspection may subject you to a penalty of \$10 per day for each day there is a failure to comply. See Internal Revenue Service Notice 88-120, 1988-2 C.B. 454, for additional information.

We express no opinion as to the marketability, reliability, or value of the bonds, whether issued or to be issued on your behalf. We have not determined whether bondholders may exclude from their gross income interest received on these bonds under sections 103 and 141 through 150 of the Code. We have not determined whether you purchased property at fair market value or leased any property at fair rental value. Bond issuing authorities should note that we have based this ruling letter only on information submitted on or before January 13, 1995.

You need an employer identification number even if you have no employees. Please use that number on all returns you file and in all correspondence with the Internal Revenue Service.

We are informing your key district office of this ruling. Because this letter could help resolve any questions about your exempt status and foundation status, you should keep it in your permanent records.

If you have any immediate questions about this ruling, please contact the person whose name and telephone number are shown in the heading of this letter. For other matters, including questions concerning reporting requirements, please contact your key district office.

Sincerely,

*Garland Carter*

Garland Carter  
Chief, Exempt Organizations  
Technical Branch 5

Enclosure:  
Pub. 1771

INTERNAL REVENUE SERVICE  
DISTRICT DIRECTOR  
P. O. BOX 2508  
CINCINNATI, OH 45201

DEPARTMENT OF THE TREASURY

Date: **APR 24 1995**

HUNTINGTON HOUSING INC  
C/O NANCY J TRICK  
11200 ROCKVILLE PIKE 2ND FLR  
ROCKVILLE, MD 20852-3103

Employer Identification Number:  
52-1879282  
DLN:  
17053024868008  
Contact Person:  
D. A. DOWNING  
Contact Telephone Number:  
(513) 241-5199  
Date of Exemption:  
January 17, 1995  
Internal Revenue Code  
Section 501(c)(03)

Dear Applicant:

Thank you for submitting the information shown on the enclosure. We have made it a part of your file.

The changes indicated do not adversely affect your exempt status and the exemption letter issued to you continues in effect.

Please let us know about any future change in the character, purpose, method of operation, name or address of your organization. This is a requirement for retaining your exempt status.

We have sent a copy of this letter to your representative as indicated in your power of attorney.

Thank you for your cooperation.

Sincerely yours,



District Director

HUNTINGTON HOUSING INC

Item Changed	From	To
Articles of Inc.	Atlantic Housing, Inc.	Huntington Housing, Inc.
Location of Low Income Housing Property	New Jersey	Brooklyn Park, Minnesota



J

# Relocation Plan

(MANDATORY, if tenants are displaced)

# ***Westside Village Apartments***

## ***Tenant Relocation Plan***

### ***PROJECT AND CONTACT INFORMATION:***

**PROJECT:** Westside Village Apartments, 2150 Sinai Road, South Boston, VA 24592

**OWNER:** Westside Village Renewal LLC, 11810 Grand Park Ave., Suite 600, North Bethesda, MD 20852

Contact: Jeff Cordisco, [jeff@foundationhousing.com](mailto:jeff@foundationhousing.com), 301-998-0409

**PROPERTY MANAGEMENT:** Dalcorm Management, 650 Pratt Ave. NW, Suite B, Huntsville, AL 35801

Contact: Stephanie McKinney, [smckinney@dalcormgmt.com](mailto:smckinney@dalcormgmt.com), 265-533-1727

### ***REHABILITATION ACTIVITIES, TIMELINE, AND UNIT DELIVERY SCHEDULE:***

Please see the attached Scope of Work for all planned rehabilitation activities. Construction is estimated to begin in February of 2021 and end in December of 2021. Units are projected to be delivered as follows - 4 units in March, 8 units each in April, May, June, July, August, September, October, and November, and 2 units in December.

### ***RESIDENT IMPACT:***

Westside Village Renewal LLC (the "Owner") is planning to complete the renovation of Westside Village Apartments while residents remain in place. The majority of residents will not need to vacate their apartments during the construction process.

All residents will be provided with a hospitality suite, during the daytime while kitchens and baths are being renovated. At the end of each work day, residents will be able to return to their apartment homes with fully functioning kitchens and baths. The hospitality suite will be made available in the community building and/or in a vacant apartment unit and will be stocked with refreshments and furnished.

Prior to the commencement of construction, representatives of the general contractor, Management Company, and Owner will host a pre-construction meeting with the residents. The scope of the construction and tentative schedule will be discussed with the residents at this time. The residents will also have the opportunity to ask the representatives any questions. In addition to the aforementioned meeting, residents will receive written notification prior to any construction occurring inside of their apartment.

### ***TEMPORARY ONSITE RELOCATION:***

The renovation plan includes combining a small number of side-by-side townhomes into garden flats in order to increase the number of ADA accessible units at the site. These apartments will require the reconfiguration of walls and major systems. Therefore, residents in these apartments will be relocated to another vacant apartment home on site and will be returned to their homes following completion of renovation within 30 days or less. This process will be completed under the following guidelines:

- The owner will pay the residents moving costs and associated costs (including utility connection costs) both to a temporary apartment and back to a newly renovated apartment.
- If (a) resident(s) agree(s), in writing, to permanently relocate to an apartment which was as designated as temporary, the owner will ensure that the cost of the move is covered and will keep record of the resident's agreement on file.
- If (a) resident(s) agree(s), in writing, to permanently relocate to another newly renovated apartment, the owner will ensure that the cost of moves to a temporary and new permanent location are covered and will keep record of the resident's agreement on file.

In these cases, the Owner realizes the inconvenience relocation to new or temporary apartment's causes and will make very aggressive efforts to minimize resident inconvenience. Working with property management, the general contractor will provide boxes, supplies, and moving services for the resident so that inconvenience is minimized and so that the resident is not asked to cover any of the costs associated with the move(s).

#### *COMPLIANCE WITH UNIFORM RELOCATION ACT:*

The Owner has a successful track record for permanently and temporarily relocating residents and will ensure all relocated residents are treated fairly and with respect throughout the process. If off-site relocation is needed, the Owner and property management will take all necessary steps to comply with the guidelines outlined in the Uniform Relocation Assistance and Real Property Acquisitions Policies Act of 1970, the Housing and Community Development Act of 1974 and the VHDA Relocation Assistance Guidelines.

#### *NOTICES:*

Property Management staff will provide adequate notice to all residents of Westside Village Apartments. These notices include the Notice of Intent to Acquire, General Information Notice, Notice of Relocation Eligibility, 30-day Notice and 120-day Notice. Preparation of the notices will be undertaken by Property Management and distribution of the notices will be completed by the on-site property management staff at Westside Village Apartments in person or via certified or registered first class mail (return receipt requested). Such notices will include the telephone number, address and name of the responsible party that can be contacted with all resident questions. On-site property management staff will ensure all residents receive a clear understanding of the notices and their relocation rights by providing translation and communication services in accordance with VHDA Relocation Assistance Guidelines.

All notices will contain the information required by federal Uniform Relocation Act requirements and by VHDA's Relocation Assistance Guidelines.

*PERMANENT RELOCATION PROCESS AND ADVISORY SERVICES:*

Permanent Relocation will not be required. However if an unforeseen issue arises making this necessary, residents needing to be permanently relocated will be immediately consulted regarding their option to relocate, the financial assistance the Owner will provide, and the other advisory assistance we will offer to guide residents through this process. Our goal will be to make the process as easy as possible for those residents impacted. Advisory services will include the following:

- Referrals for residents to replacement properties
- Contacting replacement properties to request priority for persons being displaced
- Residents will be provided with written information and/or translation services in their native languages if necessary
- Appropriate counseling for tenants who are unable to read and understand notices
- Contact information for questions and access to phone or computer if needed to make contact will be provided.
- Transportation for tenants needing to look at other housing, especially those who are elderly or disabled
- Any additional special advisory services to meet the needs of families and the elderly
- Allow and make residents aware that appointments can be scheduled outside of normal business hours if needed

If permanent relocation is required VHDA will be provided with the names and addresses of the tenants.

*MOVING COST REIMBURSEMENT:*

If for any reason a resident opts to move his/her belongings on their own, the resident will be reimbursed under the guidelines of the VHDA Relocation Assistance Guidelines. Residents will be informed that they are required to provide documentation, including bills, certified prices, appraisals and other evidence of expenses. In turn, the Owner will:

- Provide reasonable assistance necessary to complete and file residents' claims for payment
- Reimburse moving costs upon receipt of billing documentation from the resident
- Provide expedited return of security deposits or allow residents to apply security deposits to the last month's rent
- Make advanced payments, if a resident demonstrates the need, in order to avoid or reduce a hardship (often residents will need these payments for security deposits)
- Promptly notify the resident in writing of its determination, the basis for its determination and the procedures for appealing that determination, if it disapproves all or part of a payment claimed or refuses to consider the claim on its merits because of

untimely filing or other grounds

- Not propose or request that a displaced resident waive his or her rights or entitlements to relocation assistance and benefits

#### ***PROJECTED RENTS AND RENTAL POLICIES AFTER REHAB:***

It is projected that rents will not be impacted by the construction improvements. Rents are currently governed by HUD through the existing Section 8 HAP Contract in place for all 70 units. The owner will continue to submit annually OCAF rent increase requests to HUD; however the construction improvements will not impact the rents.

Rental policies will be impacted by the new compliance requirements of the LIHTC program including new maximum income requirements. In addition, 10% of the project's units will be designated for ADA qualified residents.

#### ***REPORTING TO VHDA:***

Prior to the commencement of work, the owner will provide VHDA with an updated Renovation and Relocation Plan and will distribute copies to residents. The Plan will include, among other items:

- Name, address and contact person for the owner and Management Company.
- Scope of work to be completed, phasing and estimated timetables.
- Planned measures to minimize construction impact on occupied apartments.
- Projected rents and rental policies after rehabilitation.
- Advisory services to be offered.
- Estimated determination as to Moving Cost Reimbursement.

The owner, in concert with the management agent and general contractor, will ensure that detailed records will be maintained in each resident's file. This documentation will include:

- Copies of resident notices, dates of distribution, method of distribution
- Name and addresses of tenants to be relocated permanently
- Detailed schedule of dates tenants are to be temporarily moved and the date they will be in their permanent unit or date they will be moved once to a renovated unit.
- Resident agreements -for residents agreeing to make a temporary or new apartment its permanent residence (residents not returning to their original apartment), resident agreements will be signed to evidence the resident's voluntary agreement.
- Relocation costs - invoices for all relocation related expenses will be maintained including hospitality suite costs, moving materials, moving labor, and any reimbursements provided directly to residents if off-site relocation is required.
- Certifications and reports - reports and certifications required by VHDA

No later than 30 days after the last tenant is relocated, the owner will provide to VHDA:

- A written certification by the owner that it has met VHDA Relocation Assistance Guidelines

*Westside Village Apartments*

*Estimated Unit Delivery Schedule for 2021*

Month	Units Delivered	Cumulative Units Delivered
March	4	4
April	8	12
May	8	20
June	8	28
July	8	36
August	8	44
September	8	52
October	8	60
November	8	68
December	2	70

K

Documentation of  
Development Location

**K.1**

Revitalization Area  
Certification



## **Revitalization Area Certification**

The Town of South Boston has passed a resolution to establish an ordinance that creates a revitalization area in the location of Westside Village Apartments, supporting documentation from the town has been included in this section.





# 2019 and 2020 Small DDAs and QCTs

2150 Sinai Rd, South Boston, VA 24592

Select a State  Select a County

Map Options : [Clear](#) | [Reset](#) | [Full Screen](#)

- Tract Outline
- LIHTC Project
- 2020 Qualified Census Tracts
- SADDA Boundary
- SADDA Boundary
- 2020 Small DDA

[Hide the overview](#)

The 2020 Qualified Census Tracts (QCTs) and Difficult Development Areas (DDAs) are effective January 1, 2020. The 2020 designations use data from the 2010 Decennial census and three releases of 5-year tabulations from the American Community Survey (ACS): 2010-2014; 2011-2015; and 2012-2016. The designation methodology is explained in the federal Register notice published September 25, 2019

### Map Options

- 13 Current Zoom Level
- Show Difficult Development Areas (Zoom 7+)
- Color QCT Qualified Tracts (Zoom 7+)
- Show Tracts Outline (Zoom 11+)
- Show FMR Outlines (Zoom 4+)
- Show LIHTC Projects (Zoom 11+)

[Click here for full screen map](#)

### Select Year

- 2020
- 2019

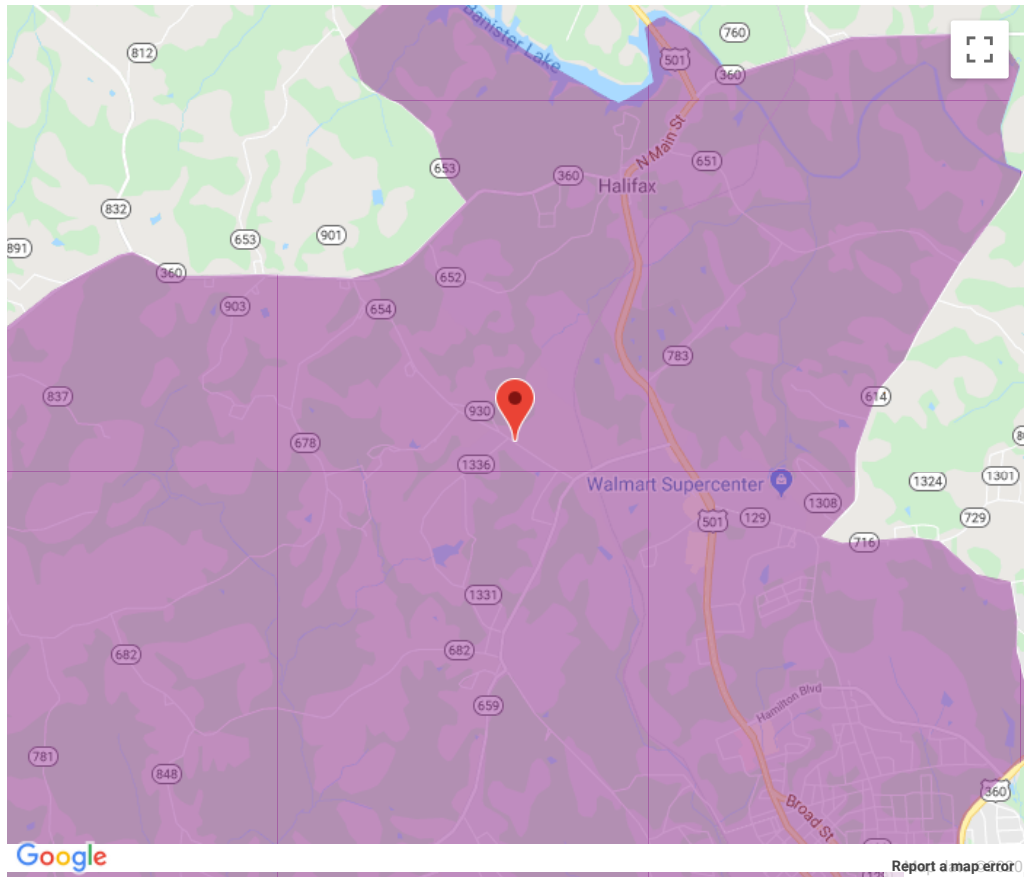

[HUD Secretary's Awards](#)

[PD&R Careers](#)

[Reports](#)

[The Edge](#)

## Reference

[Bibliographic Database](#)

[Data Sets Reference Guide](#)

[Guidelines for Preparing a Report for Publication](#)

[HUD Historical Timeline](#)

[Programs of HUD](#)

## Resources

[Disaster Recovery PD&R Toolkit](#)

[Housing Scorecard](#)

[International and Philanthropic Affairs Division](#)

[Market Analysis](#)

## More...

[Contact Us](#)

[eBookstore](#)

[HUDUser Archives](#)

[Webstore](#)

## Connect with HUD User

[Accessibility](#) | [Contact Info](#) | [Privacy Policy](#) | [FOIA](#) | [Web Management and Web Policies](#) | [Inspector General](#) | [No Fear Act](#) | [PaymentAccuracy.gov](#)



HUD USER

P.O. Box 23268, Washington, DC 20026-3268

**Toll Free:** 1-800-245-2691    **TDD:** 1-800-927-7589

**Local:** 1-202-708-3178    **Fax:** 1-202-708-9981



WESTSIDE VILLAGE APARTMENTS  
REVITALIZATION AREA RESOLUTION

VHDA Tracking Number: 2020-C-90  
Development Name: Westside Village  
Apartments Development Jurisdiction: Town  
of South Boston  
Name of Owner/Applicant: Westside Village  
Renewal LLC

WHEREAS, the above-referenced development is in an area that is either (1) blighted, deteriorated, deteriorating or, if not rehabilitated, likely to deteriorate by reason that the buildings, improvements or other facilities in such area are subject to one or more of the following conditions: dilapidation, obsolescence, overcrowding, inadequate ventilation, light or sanitation, excessive land coverage, deleterious land use, or faulty otherwise inadequate design, quality or condition; or

WHEREAS, (2) the industrial, commercial or other economic development of such area will benefit the town or county but such area lacks the housing needed to induce manufacturing, industrial, commercial, governmental, educational, entertainment, community development, healthcare or nonprofit enterprises or undertakings to locate or remain in such area; and

WHEREAS, private enterprise and investment are not reasonably expected, without assistance, to produce the construction or rehabilitation of decent, safe and sanitary housing and supporting facilities that will meet the needs of low and moderate income persons and families in such area and will induce other persons and families to live within such area and thereby create a desirable mix of residents in such area;

NOW, THEREFORE, BE IT RESOLVED, I certify that the above-referenced development is located in a Revitalization Area in my jurisdiction.

BE IT FURTHER RESOLVED THAT I understand this Certification will be used by the Virginia Housing Development Authority to determine whether the development qualifies for points available under VHDA's Qualified Allocation Plan.

Adopted this 9th day of March 2020 by the Council of the Town of South Boston.

By:

  
Edward Owens, Mayor

Attest

:

  
Jane P. Jones, Town Clerk



K.2

Location Map



930

Beverly Ct

654

Cathy St Ln

1336

654

2150 Sinai Road

Sinai Rd

Westside Dr

Country Green Apartments

654

Google



K.3

Surveyor's Certification of  
Proximity to Public  
Transportation

**N/A**



L

PHA/Section 8 Notification  
Letter

**N/A**

M

Locality CEO Response  
Letter



455 Ferry Street • South Boston, Virginia 24592 • 434.575.4200 • traab@southbostonva.us

Locality CEO Letter

March 2, 2020

Date

JD Bondurant  
Virginia Housing Development Authority  
601 South Belvidere Street  
Richmond, Virginia 23220

VHDA Tracking Number:	<u>2020-C-90</u>
Development Name:	<u>Westside Village Apartments</u>
Name of Owner/Applicant:	<u>Westside Village Renewal LLC</u>

Dear Mr. Bondurant:

The construction or rehabilitation of the above-named development and the allocation of federal housing tax credits available under IRC Section 42 for said development will help to meet the housing needs and priorities of The Town of South Boston. Accordingly, The Town of South Boston supports the allocation of federal housing tax credits requested by Westside Village Renewal LLC for this development.

Yours truly,

Signature

Thomas S. Raab

[CEO Name]

Town Manager

[Title]

**N**

Homeownership Plan

**N/A**



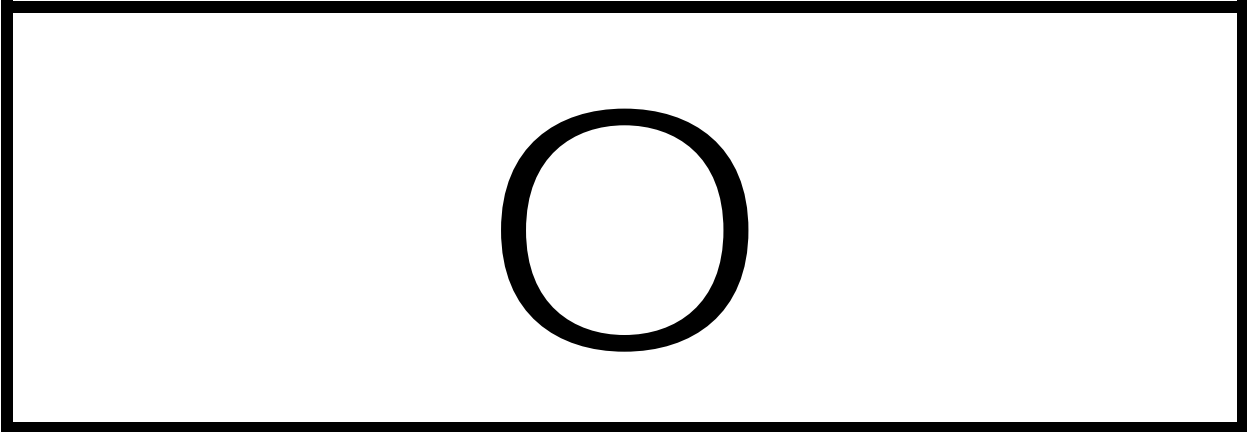

O

Plan of Development  
Certification Letter

**N/A**

P

Copies of 8609s to  
Certify Developer  
Experience and  
Partnership agreements

## VHDA Experienced LIHTC Developers

### Notes:

Updated:

1/30/2020

I Listed if 'named' Controlling General Partner or Managing Member (as confirmed by supporting documentation)

I Listed if documentation supported at least 6 LIHTC developments

I Listed if a principal who has developed at least 3 LIHTC deals and has at least \$500,000 in liquid assets

**See LIHTC Manual for instructions on being added to this list**

### INDIVIDUALS

1 Alexander, Randall P.	28 Fore, Richard L.	55 Mirmelstein, George
2 Asarch, Chad	29 Franklin, Wendell C.	56 Nelson, IV, John M.
3 Arista, Roberto	30 Friedman, Mitchell M.	57 Orth, Kevin
4 Barnhart, Richard K.	31 Gardner, Mark E.	58 Page, David
5 Baron, Richard	32 Gunderman, Timothy L.	59 Parent, Brian
6 Bennett, Vincent R.	33 Haskins, Robert G.	60 Park, Richard A.
7 Burns, Laura P.	34 Heatwole, F. Andrew	61 Park, William N.
8 Chapman, Tim	35 Honeycutt, Thomas W.	62 Pasquesi, R.J.
9 Cohen, Howard Earl	36 Hunt, Michael C.	63 Pedigo, Gerald K.
10 Connelly, T. Kevin	37 Iglesias, Adrian	64 Poulin, Brian M.
11 Connors, Cathy	38 Jester, M. David	65 Queener, Brad
12 Copeland, M. Scott	39 Johnston, Thomas M.	66 Ripley, F. Scott
13 Copeland, Robert O.	40 Jones Kirkland, Janice	67 Ripley, Ronald C.
14 Copeland, Todd A.	41 Kirkland, Milton L.	68 Ross, Stephen M.
15 Cordingley, Bruce A.	42 Kittle, Jeffery L.	69 Salazar, Tony
16 Counselman, Richard	43 Koogler, David M.	70 Sari, Lisa A.
17 Crosland, Jr., John	44 Koogler, David Mark	71 Sinito, Frank T.
18 Curtis, Lawrence H.	45 Lancaster, Dale	72 Stockmaster, Adam J.
19 Daigle, Marc	46 Lawson, Phillip O.	73 Stoffregen, Phillip J.
20 Dambly, Mark H.	47 Lawson, Steve	74 Surber, Jen
21 Deutch, David O.	48 Leon, Miles B.	75 Valey, Ernst
22 Dischinger, Chris	49 Lewis, David R.	76 Uram, David
23 Douglas, David D.	50 Margolis, Robert B.	77 Wilson, Stephen
24 Edmondson, Jim	51 McCormack, Kevin	78 Woda, Jeffrey J.
25 Ellis, Gary D.	52 McNamara, Michael L.	79 Wohl, Michael D.
26 Fekas, William L.	53 Melton, Melvin B.	80 Wolfson, III, Louis
27 Fitch, Hollis M.	54 Midura, Ronald J.	

### NON-PROFITS, LHAs & (PUBLICLY TRADED) CORPORATIONS

- 1 AHC, Inc.
- 2 Alexandria RHA
- 3 Arlington Partnership for Affordable Housing (APAH)
- 4 Atlantic Housing Foundation, Inc.
- 5 Better Housing Coalition
- 6 Buckeye Community Hope Foundation
- 7 Community Housing Partners
- 8 Community Housing, Inc.
- 9 ElderHomes (dba Project: Homes)
- 10 Enterprise Homes, Inc
- 11 Fairfax County RHA
- 12 Homes for America, Inc.
- 13 Humanities Foundation, Inc.
- 14 **Huntington Housing, Inc.**
- 15 Newport News RHA
- 16 NHT Communities
- 17 Norfolk Redevelopment Housing Authority
- 18 People Incorporated
- 19 Piedmont Housing Alliance
- 20 Preserving US, Inc.
- 21 Portsmouth RHA
- 22 RHA/Housing, Inc.
- 23 Rush Homes
- 24 The Community Builders
- 25 Virginia Supportive Housing
- 26 Virginia United Methodist Housing Development Corporation
- 27 Wesley Housing Development Corporation
- 28 LEDIC Realty Company, LLC

Q

Documentation of Rental  
Assistance

**EXHIBIT A**

**IDENTIFICATION OF UNITS ("CONTRACT UNITS")  
BY SIZE AND APPLICABLE CONTRACT RENTS**

**Section 8 Contract Number: VA36H027004**

**FHA Project Number:**

**Effective Date of the Rent Increase: 12/01/2019**

<b>Number of Contract Units</b>	<b>Number of Bedrooms</b>	<b>Contract Rent</b>	<b>Utility Allowance</b>	<b>Gross Rent</b>
8	1	\$485.00	\$62.00	\$547.00
34	2	\$565.00	\$95.00	\$660.00
22	3	\$738.00	\$113.00	\$851.00
6	4	\$781.00	\$135.00	\$916.00

**Do not submit a Gross Rent Change through TRACS until the HUD-92458 Rent Schedule has been returned to you duly executed from your HUD/PBCA office.**

- Note:
- (1) This Exhibit will be amended by Contract Administrator notice to the Owner to specify adjusted contract rent amounts as determined by the Contract Administrator in accordance with the Renewal Contract.
  - (2) These rents are applicable with the Amend Rents Automatic OCAF for this effective Date.



**ASSIGNMENT, ASSUMPTION AND AMENDMENT AGREEMENT  
SECTION 8 HOUSING ASSISTANCE PAYMENTS CONTRACT  
(Uninsured Project)**

**THIS ASSIGNMENT, ASSUMPTION AND AMENDMENT OF SECTION 8 HOUSING ASSISTANCE CONTRACT** (herein called the “**Agreement**”) is made this 16th day of January, 2020, by the United States of America, acting through the **DEPARTMENT OF HOUSING AND URBAN DEVELOPMENT** (herein called the “**Secretary**” or “**HUD**”), **NEW WESTSIDE VILLAGE I LIMITED PARTNERSHIP**, a Virginia limited liability company (herein called the “**Seller**”), and **WESTSIDE VILLAGE AFFORDABLE LLC**, a Virginia limited liability company (herein called the “**Buyer**”).

**WHEREAS**, the Secretary and Seller pursuant to Section 8 of the United States Housing Act of 1937, 42 U.S.C. 1437 (f), entered into a Section 8 Housing Assistance Payments Contract (herein called the “**HAP Contract**”) identified as HAP Contract Number VA36H027004 for 70 units in the Westside Village Apartments (herein called the “**Property**”), a copy of which is attached hereto as Exhibit A;

**WHEREAS**, the Seller and the National Foundation for Affordable Housing Solutions, Inc., a District of Columbia nonprofit corporations (the “**Assignor**”) entered into a Real Estate Purchase and Sale Agreement, dated as of September 6, 2019 (the “**PSA**”), wherein the Seller agrees to sell the Property and Assignor agree to purchase the Property, including, without limitation, the improvements situated thereon, and has agreed to accept the assignment of and assume all obligations under the HAP Contract;

**WHEREAS**, the Assignor assigned the PSA to the Buyer pursuant to that certain Assignment of Purchase and Sale Agreement by and between Assignor and Buyer dated October 1, 2019, and Buyer has agreed to accept the assignment of and assume all obligations under the HAP Contract;

**WHEREAS**, the Buyer has submitted to the Secretary of HUD (herein called the “**Secretary**”) an Application and documents in support thereof (herein collectively referred to as the “**Application**”) requesting the Secretary’s approval of the proposed assignment of the HAP Contract to the Buyer as set forth in the aforesaid Real Estate Purchase and Sale Agreement; and

**WHEREAS**, the Seller and the Buyer mutually desire to assign the HAP Contract; and it is necessary to and the Secretary and the Buyer mutually desire to amend the HAP Contract to allow for physical inspections in accordance with 24 CFR Part 5 Subpart G and require financial reporting in accordance with 24 CFR Part 5 Subpart H;

**NOW, THEREFORE**, in consideration of the foregoing, the sum of Ten Dollars (\$10.00) in hand paid and other good consideration, the receipt of which is hereby acknowledged, and in order to comply with the requirements of the Secretary, the United States Housing Act of 1937, and the regulations adopted pursuant thereto, the parties hereto agree as follows:



1. The Seller hereby irrevocably assigns HAP Contract to the Buyer together with all rights and obligations in and under said contract;

2. Effective as of the date of this Agreement the Buyer agrees to assume and to be bound by said HAP Contract as modified herein and is responsible for filing the Annual Financial Statement (AFS) from the date of this Agreement through the end of the Buyer's fiscal year.

3. Effective as of the date of this Agreement, the Seller is released from any future obligations under the HAP Contract, excepting that the Seller shall remain responsible for filing the AFS through the day before this Agreement if said HAP Contract includes an AFS filing requirement. Nothing in this Agreement shall waive, compromise, impair, or prejudice any right HUD may have against the Seller for any violation of the HAP Contract that may have occurred prior to the date of this Agreement.

4. Part II of the HAP Contract shall be amended as follows to include the following provisions:

**Physical Conditions Standards and Inspection Requirements.** The Owner shall comply with the Physical Condition Standards and Inspection Requirements of 24 CFR Part 5, Subpart G, including any changes in the regulation and related Directives. In addition, the Owner shall comply with HUD's Physical Condition Standards of Multifamily Properties of 24 CFR Part 200, Subpart P, including any changes in the regulation and related Directives. This obligation shall apply both during the current term of the HAP contract and during each successive renewal term.

**Financial Reporting Standards.** The Owner shall comply with the Uniform Financial Reporting Standards of 24 CFR Part 5, Subpart H, including any changes in the regulation and related Directives. This obligation shall apply during the current term of the HAP Contract and for each successive renewal term.

5. This Agreement shall be construed under the laws of the Commonwealth of Virginia and to the extent inconsistent with the laws of the Commonwealth of Virginia, the laws of the United States of America. This Agreement shall be binding upon and shall inure to the benefit of the parties hereto and their respective successors and assigns.

6. This Agreement may be executed in any number of counterparts, each of which shall be considered an original for all purposes; provided, however, that all such counterparts shall together constitute one and the same instrument.

7. The Secretary, by the signature of his authorized representative below, consents to assignment made hereby. Said consent shall be void ab initio if the Secretary determines that Buyer, or any principal or interested party of the Buyer, is debarred, suspended or subject to a limited denial of participation under 24 CFR Part 24, or is listed on the U.S. General Services Administration list of parties excluded from Federal procurement or nonprocurement programs.

**NOTHING** in this Agreement shall in anyway impair the HAP Contract or alter, waive, annul, vary or affect any provision, condition, covenant therein, except as herein specifically provided, or affect or impair any rights, powers, or remedies under the HAP Contract, it being the intent of the parties hereto that the terms and conditions of the HAP Contract shall continue in full force and effect except as amended hereby.

*[Signatures appear on the following page]*

[Signature page for Assignment, Assumption and Amendment of HAP Agreement – Westside Village Apartments]

**IN WITNESS WHEREOF**, the Seller, the Buyer, and the Secretary have caused this agreement to be executed.

**SELLER:**

**NEW WESTSIDE VILLAGE I LIMITED PARTNERSHIP**, a Virginia limited partnership

By: MARG Rural LLC, its general partner

By:

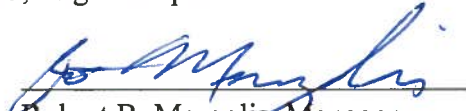
  
Robert B. Margolis, Manager

[Signature page for Assignment, Assumption and Amendment of HAP Agreement – Westside Village Apartments]

**BUYER:**

**WESTSIDE VILLAGE AFFORDABLE LLC**, a Virginia limited liability company

By: Echelon Housing, Inc., a Maryland  
nonprofit corporation, its sole member

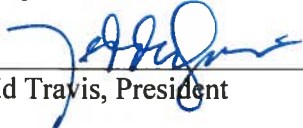
By:   
\_\_\_\_\_  
Todd Travis, President

[Signature page for Assignment, Assumption and Amendment of HAP Agreement – Westside Village Apartments]

**SECRETARY:**

**SECRETARY OF HOUSING AND URBAN DEVELOPMENT, Acting by and through the  
FEDERAL HOUSING COMMISSIONER**

By:

  
\_\_\_\_\_  
Authorized Agent

1/8/2020

**EXHIBIT A**

U. S. DEPARTMENT OF HOUSING AND URBAN DEVELOPMENT  
SECTION 8 HOUSING ASSISTANCE PAYMENTS PROGRAM  
HOUSING FINANCE AND DEVELOPMENT AGENCIES

PART I OF THE

HOUSING ASSISTANCE PAYMENTS CONTRACT

NEW CONSTRUCTION OR SUBSTANTIAL REHABILITATION

MASTER SECTION 8 ACC NUMBER: P-5512	ACC LIST NUMBER AND DATE: P-77-004 10/29/76	NEW CONSTRUCTION PROJECT NUMBER: VA 36-H027-004 SUBSTANTIAL REHABILITATION PROJECT NUMBER:
--	--	--

This Housing Assistance Payments Contract ("Contract") is entered into by and between the VIRGINIA HOUSING DEVELOPMENT AUTHORITY a housing finance agency ("HFA"), which is a public housing agency as defined in the United States Housing Act of 1937, 42 U.S.C. 1437, et seq. ("Act"), at section 1437a(b), and WESTSIDE VILLAGE ASSOCIATES ("Owner"), and approved by the United States of America acting through the Department of Housing and Urban Development ("Government"), pursuant to the Act and the Department of Housing and Urban Development Act, 42 U.S.C. 3531, et seq.

The parties hereto agree as follows:

1.1 SIGNIFICANT DATES AND OTHER ITEMS: CONTENTS OF CONTRACT

- a. Effective Date of Contract. The effective date of this Contract is See Exhibits A-1 & A-2, 1976. [This date shall be no earlier than the date of submission by the HFA to the Government of the certifications required by 24 CFR, Section 853.316(a).]
- b. Initial Term of Contract. The initial term of this Contract (see Section 1.4a) shall be 5 years [not to exceed five years], beginning with the effective date of this Contract and ending See Exhibits A-1 & A-2, 1976.
- c. Number and Length of Optional Additional Terms. The number and length of optional additional terms (see Section 1.4a) shall be 5 terms of 5 years each [not to exceed five years each].
- d. Maximum Total Term of Contract. The maximum total term of this Contract for any unit, including all renewals, shall be as specified in Section 1.4a.
- e. Fiscal Year. The ending date of each Fiscal Year (see Section 1.4b) shall be June 30 [insert March 31, June 30, September 30, or December 31, as determined by the Government].
- f. Annual Contributions Contract. The Annual Contributions Contract applicable to this Contract ("ACC") (see Section 1.5a) is the ACC dated NOVEMBER 8, 1976, with respect to Project No. VA 36-H027-004.
- g. Maximum Housing Assistance Commitment. The maximum amount of the commitment for housing assistance payments under this Contract (see Section 1.6a) is 262,176.00 per annum. [Enter amount specified in the ACC for housing assistance payments, exclusive of the Financing Cost Congingency.] This amount shall be subject to increase pursuant to Section 1.5c(2) or 1.5f(3) of the Agreement or Section 1.9c(3) of this Contract, as appropriate.
- h. Percent of Units to be Leased to Very Low-Income Families. In the initial renting of the Contract Units, the minimum percentage of those units required to be leased to Very Low-Income Families (see Section 1.10c(1)) shall be 30 percent.

1. Contents of Contract. This Contract consists of Part I, Part II, and the following exhibits:

- Ex A: The schedule showing the number of units by size ("Contract Units") and their applicable rents ("Contract Rents");
- Exhibit B: The project description;
- Exhibit C: The statement of services, maintenance and utilities to be provided by Owner;
- Exhibit D: The Affirmative Fair Housing Marketing Plan, if applicable; and

Additional exhibits: [Specify additional exhibits, if any. If none, insert "None."] Exhibits A-1 and A-2 attached hereto.

This Contract, including said exhibits, comprises the entire agreement between the parties hereto with respect to the matters contained herein, and neither party is bound by any representations or agreements of any kind except as contained herein or except agreements entered into in writing which are not inconsistent with this Contract.

1.2 OWNER'S WARRANTIES.

- a. Legal Capacity. The Owner warrants that he has the legal right to execute this Contract and to lease dwelling units covered by this Contract.
- b. Completion of Work. The Owner warrants that the project as described in Exhibit B is in good and tenantable condition and that the project has been completed in accordance with the terms and conditions of the Agreement to Enter into Housing Assistance Payments Contract ("Agreement") or will be completed in accordance with the terms on which the project was accepted. The Owner further warrants that he will remedy any defects or omissions covered by this warranty if called to his attention within 12 months of the effective date of this Contract. The Owner and the HFA agree that the continuation of this Contract shall be subject to the conditions set forth in Section 1.4b of the Agreement.

1.3 FAMILIES TO BE HOUSED; HFA ASSISTANCE.

- a. Families to Be Housed. The Contract Units are to be leased by the Owner to eligible Lower-Income Families ("Families") for use and occupancy by such Families solely as private dwellings.
- b. HFA Assistance.

(1) The HFA hereby agrees to make housing assistance payments on behalf of Families for the Contract Units, to enable such Families to leave Decent, Safe, and Sanitary housing pursuant to section 8 of the Act. Such housing assistance payments shall equal the difference between the Contract Rents for units leased by Families and the portion of such rents payable by Families as determined by the Owner in accordance with schedules and criteria established by the Government.

(2) If there is an Allowance for Utilities and Other Services and if such Allowance exceeds the Gross Family Contribution, the Owner shall pay the Family the amount of such excess on behalf of the HFA upon receipt of funds from the HFA for that purpose.

#### 1.4 TERM OF CONTRACT; FISCAL YEAR.

- a. Term of Contract.  
[Alternative provisions—incorporate alternative 1, 2, or 3, as applicable.]

##### ALTERNATIVE 1—GENERAL:

The initial term of this Contract shall be as stated in Section 1.1b. This Contract may be renewed for the number and length of additional terms stated in Section 1.1c, provided that the total Contract term for any unit, including all renewals, shall not exceed the shorter of (1) 40 years or (2) a period terminating on the date of the last payment of principal due on the permanent financing [insert in (1) a number of years equal to the maximum anticipated number of years during which assistance payments will be made, not to exceed 40 years]. Renewals shall be automatic unless either party notifies the other in writing, no later than 60 days prior to the expiration of the current term, of his desire not to renew, and the other party agrees in writing that there shall be no renewal. If the project is completed in stages, the dates for the initial term and renewal terms shall be separately related to the units in each stage; Provided, however, that the total Contract term for all the stages, beginning with the effective date of the Contract with respect to the first stage, shall not exceed the total Contract term for any unit specified in this paragraph, plus two years. In any case where the project is owned by, or financed by a loan or loan guarantee from, a State or local agency, the housing assistance payments pursuant to this Contract with respect to any dwelling unit shall be payable over a period not to exceed 40 years.

##### ALTERNATIVE 2—FOR MOBILE HOMES PROJECT:

~~The term of this Contract shall be as stated in Section 1.1b. This Contract may be renewed for the number and length of additional terms stated in Section 1.1c, provided that the total Contract term for any mobile home, including all renewals, shall not exceed \_\_\_\_\_ years. [Insert number as authorized by the Government pursuant to 24 CFR, Section 553.206.] Renewals shall become effective only if either party gives written notice, with a copy to the Government, no later than 60 days prior to the expiration of the current term, of his desire to renew, and the other party and the Government give their written concurrence and approval, respectively, before the expiration of the current term. If the project is completed in stages, the dates for the initial term and renewal terms shall be separately related to the mobile home in each stage; Provided, however, that the total Contract term for all the stages, beginning with the effective date of the Contract with respect to the first stage, shall not exceed the total Contract term stated in Section 1.1d, plus two years. For purposes of this paragraph a, the term "mobile home" means the original mobile home.~~

##### ALTERNATIVE 3—FOR CERTAIN SUBSTANTIAL REHABILITATION PROJECTS:

~~For a substantial rehabilitation project, the term of this Contract shall be as stated in Section 1.1b. This Contract may be renewed for the number and length of additional terms stated in Section 1.1c, provided that the total Contract term for any unit, including all renewals, shall not exceed \_\_\_\_\_ years. [Insert number as authorized by the Government pursuant to 24 CFR, Section 553.206.] Renewals shall become effective only if either party gives written notice, with a copy to the Government, no later than 60 days prior to the expiration of the current term, of his desire to renew, and the other party and the Government give their written concurrence and approval, respectively, before the expiration of the current term. If the project is completed in stages, the dates for the initial term and renewal terms shall be separately related to the units in each stage; Provided, however, that the total Contract term for all the stages, beginning with the effective date of the Contract with respect to the first stage, shall not exceed said Contract term, plus two years.~~

- b. Fiscal Year. The Fiscal Year for the project shall be the 12-month period ending on the date stated in Section 1.1e; Provided, however, that the first Fiscal Year for the project shall be the period beginning with the effective date of the Contract and ending on the last day of said established Fiscal Year which is not less than 12 months after such effective date. If the first Fiscal Year exceeds 12 months, the maximum total annual housing assistance payment in Section 1.6a may be adjusted by the addition of the pro rata amount applicable to the period of operation in excess of 12 months.

#### 1.5 ANNUAL CONTRIBUTIONS CONTRACT.

- a. Identification of Annual Contributions Contract. The HFA has entered into an Annual Contributions Contract with the Government, as identified in Section 1.1j, under which the Government will provide financial assistance to the HFA pursuant to section 8 of the Act for the purpose of making housing assistance payments. A copy of the ACC shall be provided upon request.
- b. HFA Pledge of ACC Payments. The HFA hereby pledges to the payment of housing assistance payments pursuant to this Contract plus annual contributions payable under the ACC for such housing assistance payments. The HFA shall not, without the consent of the Owner, amend or modify the ACC in any manner which would reduce the amount of such annual contributions, except as authorized in the ACC and this Contract.
- c. Government Approval of Housing Assistance Payments Contract. The approval of this Contract by the Government signifies that the Government has executed the ACC and that the ACC has been properly authorized; that the faith of the United States is solemnly pledged to the payment of annual contributions pursuant to said ACC; and that funds have been obligated by the Government for such payments to assist the HFA in the performance of its obligations under the Contract.

#### 1.6 MAXIMUM HOUSING ASSISTANCE COMMITMENT; PROJECT ACCOUNT.

- a. Maximum Housing Assistance Commitment. Notwithstanding any other provisions of this Contract (other than paragraph b of this Section) or any provisions of any other contract between the HFA and the Owner, the HFA shall not be obligated to make and shall not make any housing assistance payments under this Contract in excess of the amount per annum stated in Section 1.1g; Provided, however, that this amount shall be reduced commensurately with any reduction in the number of Contract Units or in the Contract Rents or pursuant to any other provision of the ACC or this Contract (except reductions in Contract Rents pursuant to Section 1.9e(1)).
- b. Project Account. As provided in the ACC, in order to assure that housing assistance payments will be increased on a timely basis to cover increases in Contract Rents or decreases in Family Incomes:
- (1) A Project Account shall be established and maintained, in an amount as determined by the Government consistent with its responsibilities under section 8(c)(4) of the Act, out of amounts by which the Maximum ACC Commitment per year (exclusive of any Finance Cost Contingency) exceeds amounts paid under the ACC for any Fiscal Year. This account shall be established and maintained by the Government as a specifically identified and segregated account. To the extent funds are available in said account, the maximum total annual housing assistance payments for any Fiscal Year may exceed the maximum amount stated in paragraph a of this Section to cover increases in Contract Rents or decreases in Family Incomes (see Section 1.9). Any amount remaining in said account after payment of the last housing assistance payment with respect to the project shall be applied by the Government in accordance with law.
  - (2) Whenever the Government approved estimate of the required Annual Contribution exceeds the Maximum ACC Commitment then in effect (exclusive of any Finance Cost Contingency), and would cause the amount in the Project Account to be less than an amount equal to 40 percent of such Maximum ACC Commitment, the Government shall, within a reasonable period of time, take such additional steps authorized by section 8(c)(4) of the Act as may be necessary to carry out this assurance, including (as provided in that section of the Act) "the reservation of annual contributions authority for the purpose of amending housing assistance contracts or the allocation of a portion of new authorizations for the purpose of amending housing assistance contracts."



1.7 HOUSING ASSISTANCE PAYMENTS TO OWNERS.

a. General.

- (1) Housing assistance payments shall be paid to the Owner for units under lease by Families in accordance with the Contract. The housing assistance payment will cover the difference between the Contract Rent and that portion of said rent payable by the Family as determined in accordance with the Government-established schedules and criteria.
- (2) The amount of housing assistance payment payable on behalf of a Family and the amount of rent payable by such Family shall be subject to change by reason of changes in Family Income, Family composition, or extent of exceptional medical or other unusual expenses in accordance with the Government-established schedules and criteria; or by reason of adjustment by the HFA of any applicable Allowance for Utilities and Other Services. Any such change shall be effective as of the date stated in a notification of such change to the Family.

- b. Vacancies During Rent-up. If a Contract Unit is not leased as of the effective date of the Contract, the Owner shall be entitled to housing assistance payments in the amount of 20 percent of the Contract Rent for the unit for a vacancy period not exceeding 60 days from the effective date of the Contract, provided that the Owner (1) commenced marketing and otherwise complied with Section 1.3b of the Agreement, (2) has taken and continues to take all feasible actions to fill the vacancy, including, but not limited to, contacting applicants on his waiting list, if any, requesting the HFA and other appropriate sources to refer eligible applicants, and advertising the availability of the unit, and (3) has not rejected any eligible applicant, except for good cause acceptable to the HFA.

c. Vacancies After Rent-up.

- (1) If a Family vacates its unit (other than as a result of action by the Owner which is in violation of the Lease or the Contract or any applicable law), the Owner shall receive housing assistance payments in the amount of 80 percent of the Contract Rent for a vacancy period not exceeding 60 days; Provided, however, that if the Owner collects any of the Family's share of the rent for this period in an amount which, when added to the 80 percent payments, results in more than the Contract Rent, such excess shall be payable to the Government or as the Government may direct. (See also Section 1.10b.) The Owner shall not be entitled to any payment under this subparagraph unless he: (i) immediately upon learning of the vacancy, has notified the HFA of the vacancy or prospective vacancy and the reasons for the vacancy, and (ii) has taken and continues to take the actions specified in paragraphs b(2) and b(3) of this Section.
- (2) If the Owner evicts a Family, he shall not be entitled to any payment under paragraph c(1) of this Section unless the request for such payment is supported by a certification that (i) he gave such Family a written notice of the proposed eviction, stating the grounds and advising the Family that it had 10 days within which to present its objections to the Owner in writing or in person and (ii) the proposed eviction was not in violation of the Lease or the Contract or any applicable law.

- d. Limitation on Payments for Vacant Units. The Owner shall not be entitled to housing assistance payments with respect to vacant units under this Section to the extent he is entitled to payments from other sources (e.g., payments for losses of rental income incurred for holding units vacant for relocations pursuant to Title I of the Housing and Community Development Act of 1974 or payments under Section 1.10b of this Contract).

- e. HFA Not Obligated for Family Rent. The HFA has not assumed any obligation for the amount of rent payable by any Family or the satisfaction of any claim by the Owner against any Family other than in accordance with Section 1.10b of this Contract.

f. Owner's Monthly Requests for Payments.

- (1) The Owner shall submit monthly requests to the HFA or as directed by the HFA for housing assistance payments. Each such request shall set forth: (i) the name of each Family and the address and/or number of the unit leased by the Family; (ii) the address and/or the number of units, if any, not leased to Families for which the Owner is claiming payments; (iii) the Contract Rent as set forth in Exhibit A for each unit for which the Owner is claiming payments; (iv) the amount of rent payable by the Family leasing the unit (or, where appropriate, the amount to be paid the Family in accordance with Section 1.3b(2)); and (v) the total amount of housing assistance payments requested by the Owner.
- (2) Each of the Owner's monthly requests shall contain a certification by him that to the best of his knowledge and belief (i) the dwelling unit is in Decent, Safe, and Sanitary condition, (ii) all the other facts and data on which the request for funds is based are true and correct, (iii) the amount requested has been calculated in accordance with the provisions of this Contract and is payable under the Contract, and (iv) none of the amount claimed has been previously claimed or paid.
- (3) If the Owner has received an excessive payment, the HFA or the Government, in addition to any other rights to recovery, may deduct the amount from any subsequent payment or payments.
- (4) The Owner's monthly requests for housing assistance payments shall be made subject to penalty under 18 U.S.C. 1001, which provides, among other things, that whoever knowingly and willfully makes or uses a document or writing containing any false, fictitious, or fraudulent statement or entry, in any matter within the jurisdiction of any department or agency of the United States, shall be fined not more than \$10,000 or imprisoned for not more than five years, or both.

g. Recoupment of Savings in Financing Cost.

- (1) In the event that interim financing is used and is continued after the first year of the term of the Contract and the debt service of the interim financing for any period of three months, after such first year, is less than the anticipated debt service under the permanent financing on which the Contract Rents were based, an amount reflecting the savings in financing cost, computed in accordance with paragraph g(2) of this Section, shall be credited by the Government to the Project Account, and withheld from housing assistance payments to the Owner. If during the course of the same year there is any period of three months in which the debt service is greater than the anticipated debt service under the permanent financing, an adjustment shall be made so that only the net amount of savings in financing cost for the year is credited by the Government to the Project Account and withheld by the HFA from the Owner as aforesaid (no increased payments shall be made to the Owner on account of any net excess for the year of actual interim debt service over the anticipated debt service under the permanent financing). Nothing in this paragraph g shall be construed as requiring a reduction in the Contract Rents or precluding adjustments of Contract Rents in accordance with Section 1.9.
- (2) The computation and recoupment under this paragraph g may be made on an annual or on a quarterly or other periodic basis, but in any event no later than as of the end of each Fiscal Year; Provided, however, that if recoupment is to be made less often than quarterly, the amounts of recoupment shall be computed on at least a quarterly basis and funds shall be deposited in a special account from which withdrawals may be made only with the authorization of the HFA. The manner of computing the amount of recoupment shall be as follows:
  - (i) Determine the amount by which the debt service for the interim financing for the period in question is less than the anticipated debt service under the permanent financing on which the Contract Rents were based;
  - (ii) Determine what percentage the amount found under paragraph g(2)(i) of this Section is of the aggregate Contract Rents for all Contract Units for the period in question;

(iii) Apply the percentage found in paragraph g(2)(ii) of this Section to the aggregate Contract Rents for those Contract Units which are included in the Owner's claim(s) for housing assistance payments for the period in question, and

(iv) The amount found in paragraph g(2)(ii) of this Section shall be credited to the Project Account and withheld from the next housing assistance payment or payments to the Owner.

b<sup>1</sup> Payments by HFA. The amount of the housing assistance payment, determined in accordance with the provisions of this Contract, up to the amount of the mortgage repayments due the HFA from the Owner pursuant to the mortgage loan made by the HFA for the project, shall be credited to the Owner and transferred monthly by the HFA from the account maintained under the General Depository Agreement pursuant to the ACC to the trustee under the note or bond resolution of the HFA under which the notes or bonds to provide the mortgage loan were issued. Any amount of the housing assistance payment in excess of such credit shall be paid by the HFA directly to the Owner.

#### 1.8 MAINTENANCE, OPERATION AND INSPECTION.

a. Maintenance and Operation. The Owner agrees (1) to maintain and operate the Contract Units and related facilities so as to provide Decent, Safe, and Sanitary housing, and (2) to provide all the services, maintenance and utilities set forth in Exhibit C. If the HFA determines that the Owner is not meeting one or more of these obligations, the HFA shall have the right, in addition to its other rights and remedies under this Contract, to abate housing assistance payments in whole or in part.

#### b. Inspections Prior to Occupancy.

(1) Prior to occupancy of any unit by a Family, the Owner and the Family shall inspect the unit and both shall certify, on forms prescribed by the Government, that they have inspected the unit and have determined it to be Decent, Safe, and Sanitary in accordance with the criteria provided in the prescribed forms. Copies of these reports shall be kept on file by the Owner for at least three years.

(2) The HFA shall inspect or cause to be inspected each Contract Unit and related facilities at least annually and at such other times (including prior to initial occupancy and reletting of any unit) as may be necessary to assure that the Owner is meeting his obligation to maintain the units in Decent, Safe, and Sanitary condition and to provide the agreed upon utilities and other services. The HFA shall take into account complaints by occupants and any other information coming to its attention in scheduling inspections and shall notify the Owner and the Family of its determination.

c. Units Not Decent, Safe, and Sanitary. If the HFA notifies the Owner that he has failed to maintain a dwelling unit in Decent, Safe, and Sanitary condition and the Owner fails to take corrective action within the time prescribed in the notice, the HFA may exercise any of its rights or remedies under the Contract, including abatement of housing assistance payments, even if the Family continues to occupy the unit. If, however, the Family wishes to be rehoused in another dwelling unit with section 8 assistance and the HFA does not have other section 8 funds for such purposes, the HFA may use the abated housing assistance payments for the purpose of rehousing the Family in another dwelling unit. Where this is done, the Owner shall be notified that he will be entitled to resumption of housing assistance payments for the vacated dwelling unit if (1) the unit is restored to Decent, Safe, and Sanitary condition, (2) the Family is willing to and does move back into the restored unit, and (3) a deduction is made for the expenses incurred by the Family for both moves.

d. Notification of Abatement. Any abatement of housing assistance payments shall be effective as provided in written notification to the Owner. The HFA shall promptly notify the Family of any such abatement.

e. Overcrowded and Underoccupied Units. If the HFA determines that a Contract Unit is not Decent, Safe, and Sanitary by reason of increase in Family size, or that a Contract Unit is larger than appropriate for the size of the Family in occupancy, housing assistance payments with respect to such unit will not be abated, unless the Owner fails to offer the Family a suitable unit as soon as one becomes vacant and ready for occupancy. In the case of an overcrowded unit, if the Owner does not have any suitable units or if no vacancy of a suitable unit occurs within a reasonable time, the HFA will assist the Family in finding a suitable dwelling unit and require the Family to move to such a unit as soon as possible. The Owner may receive housing assistance payments for the vacated unit if he complies with the requirements of Section 1.7c(1).

#### 1.9 RENT ADJUSTMENTS.

a. Funding of Adjustments. Housing assistance payments will be made in increased amounts commensurate with Contract Rent adjustments under this Section up to the maximum amount authorized under Section 1.6 of this Contract.

#### b. Automatic Annual Adjustments.

(1) Automatic Annual Adjustment Factors will be determined by the Government at least annually; interim revisions may be made as market conditions warrant. Such Factors and the basis for their determination will be published in the Federal Register. These published Factors will be reduced appropriately by the Government where utilities are paid directly by the Families.

(2) On each anniversary date of the Contract, the Contract Rents shall be adjusted by applying the applicable Automatic Annual Adjustment Factor most recently published by the Government. Contract Rents may be adjusted upward or downward, as may be appropriate; however, in no case shall the adjusted Contract Rents be less than the Contract Rents on the effective date of the Contract.

c. Special Additional Adjustments. Special additional adjustments shall be granted, when approved by the Government, to reflect increases in the actual and necessary expenses of owning and maintaining the Contract Units which have resulted from substantial general increases in real property taxes, utility rates, or similar costs (i.e., assessments, and utilities not covered by regulated rates), but only if and to the extent that the Owner or the HFA clearly demonstrates that such general increases have caused increases in the Owner's operating costs which are not adequately compensated for by automatic annual adjustments. The Owner or the HFA shall submit to the Government financial statements which clearly support the increase.

d. Overall Limitation. Notwithstanding any other provisions of this Contract, adjustments as provided in this Section shall not result in material differences between the rents charged for assisted and comparable unassisted units, as determined by the HFA (and approved by the Government, in the case of adjustments under paragraph c of this Section); provided, that this limitation shall not be construed to prohibit differences in rents between assisted and comparable unassisted units to the extent that such differences may have existed with respect to the initial Contract Rents.

e. Adjustment to Reflect Actual Cost of Permanent Financing. This paragraph e shall apply if the project is not permanently financed until after the effective date of the Contract. After the project is permanently financed, the HFA shall submit a certification to the Government as to the actual financing terms and the following provisions shall apply:

(1) If the actual debt service under the permanent financing is lower than the anticipated debt service on which the Contract Rents were based, the Contract Rents currently in effect shall be reduced commensurately, and the amount of the savings shall be credited to the Project Account. The Maximum ACC Commitment shall not be reduced except by the amount of the contingency, if any, which was included for possible increases under paragraph e(2) of this Section.

(2) If the actual debt service under the permanent financing is higher than the anticipated debt service on which the Contract Rents were based, and the HFA is using its set-aside for the project, the Contract Rents currently in effect shall be increased commensurately, not to exceed the limitations in this paragraph e(2) and the amount of the Financing Cost Contingency in the ACC, if the projected borrowing rate (net interest cost) was not less than the average net interest cost for the preceding quarter (at the time the projection was submitted to the Government) of the "20 Bond Index" published weekly in the Bond Buyer, plus 50 basis points. An adjustment under this paragraph e(2) shall not be more than is necessary to reflect an increase in debt service (based upon the original projected capital cost and the actual term of the permanent financing for the project) resulting from an increase in interest rate of not more than:

(i) One and one-half percent if the projected spread as submitted to the Government was three-fourths of one percent or less, or

(ii) One percent if such projected spread was more than three-fourths of one percent but not more than one percent, or

<sup>1</sup>Use of this Section 1.7h is optional.

(iii) One half of one percent if such projected spread was more than one percent.

(3) After Contract Rents have been adjusted in accordance with paragraph e(1) or e(2) of this Section, the maximum amount of the ACC commitment shall be reduced by the amount of any unused portion of the Financing Cost Contingency, and such portion shall be re-allocated to the then current set-aside of the HFA, if any. At the same time, if the Contract Rents have been increased in accordance with paragraph e(2) of this Section, the maximum Contract amount specified in Section 1.1 g shall be increased commensurately.

f. Incorporation of Rent Adjustment. Any adjustment in Contract Rents shall be incorporated into Exhibit A by a dated addendum to the exhibit establishing the effective date of the adjustment.

#### 1.10 MARKETING AND LEASING OF UNITS.

a. Compliance with Equal Opportunity. Marketing of units and selection of Families by the Owner shall be in accordance with the Owner's Government-approved Affirmative Fair Housing Marketing Plan, shown as Exhibit D, and with all regulations relating to fair housing advertising.

b. Security and Utility Deposits.

(1) The Owner may require Families to pay a security deposit in an amount equal to one month's Gross Family Contribution. If a Family vacates its unit, the Owner, subject to State and local law, may utilize the deposit as reimbursement for any unpaid rent or other amount owed under the Lease. If the Family has provided a security deposit, and it is insufficient for such reimbursement, the Owner may claim reimbursement from the HFA, not to exceed an amount equal to the remainder of one month's Contract Rent. Any reimbursement under this Section shall be applied first toward any unpaid rent. If a Family vacates its unit owing no rent or other amount under the Lease, or if the amount owed is less than the amount of the security deposit, the Owner shall refund the full amount or the unused balance, as the case may be, to the Family.

(2) In those jurisdictions where interest is payable by the Owner on security deposits, the refunded amount shall include the amount of interest payable. All security deposit funds shall be deposited by the Owner in a segregated bank account, and the balance of this account, at all times, shall be equal to the total amount collected from tenants then in occupancy, plus any accrued interest. The Owner shall comply with all State and local laws regarding interest payments on security deposits.

(3) Families shall be expected to obtain the funds to pay security and utility deposits, if required, from their own resources and/or other private or public sources.

c. Eligibility, Selection and Admission of Families.

(1) The Owner shall be responsible for determination of eligibility of applicants, selection of families from among those determined to be eligible, and computation of the amount of housing assistance payments on behalf of each selected Family in accordance with schedules and criteria established by the Government. In the initial renting of the Contract Units, the Owner shall lease at least that percentage of those units which is stated in Section 1.1h to Very Low-Income Families (determined in accordance with the Government-established schedules and criteria) and shall thereafter exercise his best efforts to maintain at least that percentage of occupancy of the Contract Units by Very Low-Income Families as determined in accordance with such schedules and criteria.

(2) The Lease entered into between the Owner and each selected Family shall be on the form of Lease approved by the Government.

(3) The Owner shall make a reexamination of Family Income, composition, and the extent of medical or other unusual expenses incurred by the Family, at least annually (except that such reviews may be made at intervals of no longer than two years in the case of elderly Families), and appropriate redeterminations shall be made by the Owner of the amount of Family contribution and the amount of housing assistance payment, all in accordance with schedules and criteria established by the Government. In connection with the reexamination, the Owner shall determine what percentage of Families in occupancy are Very Low-Income Families. If there are fewer than the agreed to percentage of Very Low-Income Families in occupancy, the Owner shall report the fact to the HFA and shall adopt changes in his admission policies to achieve, as soon as possible, at least the agreed to percentage of occupancy by such Families.

d. Rent Redetermination after Adjustment in Allowance for Utilities and Other Services. In the event that the Owner is notified of an HFA determination making an adjustment in the Allowance for Utilities and Other Services applicable to any of the Contract Units, the Owner shall promptly make a corresponding adjustment in the amount of rent to be paid by the affected Families and the amount of housing assistance payments.

e. Processing of Applications and Complaints. The Owner shall process applications for admission, notifications to applicants, and complaints by applicants in accordance with applicable HFA or Government requirements and shall maintain records and furnish such copies or other information as may be required by the HFA or the Government.

f. Review; Incorrect Payments. In making housing assistance payments to Owners, the HFA or the Government will review the Owner's determinations under this Section. If as a result of this review, or other reviews, audits or information received by the HFA or the Government at any time, it is determined that the Owner has received improper or excessive housing assistance payments, the HFA or the Government shall have the right to deduct the amount of such overpayments from any amounts otherwise due the Owner, or otherwise effect recovery thereof.

1.11 TERMINATION OF TENANCY. The Owner shall be responsible for termination of tenancies, including evictions. However, conditions for payment of housing assistance payments for any resulting vacancies shall be as set forth in Section 1.7c.

1.12 REDUCTION OF NUMBER OF CONTRACT UNITS FOR FAILURE TO LEASE TO ELIGIBLE FAMILIES.

- a. After First Year of Contract. If at any time, beginning six months after the effective date of this Contract, the Owner fails for a continuous period of six months to have at least 80 percent of the Contract Units leased or available for leasing by Families, the HFA, with Government approval, may on 30 days notice reduce the number of Contract Units to not less than the number of units under lease or available for leasing by Families, plus 10 percent of such number if the number is 10 or more, rounded to the next highest number.
- b. At End of Initial and Each Renewal Term. At the end of the initial term of the Contract and of each renewal term, the HFA, with Government approval, may, by a vote to the Owner, reduce the number of Contract Units to not less than (1) the number of units under lease or available for leasing by Families at that time or (2) the average number of units so leased or available for leasing during the last year, whichever is the greater, plus 10 percent of such number if the number is 10 or more, rounded to the next highest number.
- c. Restoration of Units. The Government will agree to an amendment of the ACC to provide for subsequent restoration of any reduction made pursuant to paragraphs a or b of this Section if the Government determines that the restoration is justified as a result of changes in demand and in the light of the Owner's record of compliance with his obligations under the Contract and if annual contributions contract authority is available; and the Government will take such steps authorized by section 8(e)(6) of the Act as may be necessary to carry out this assurance (see Section 1.6).

WARNING: 18 U.S.C. 1001 provides, among other things, that whoever knowingly and willfully makes or uses a document or writing containing any false, fictitious, or fraudulent statement or entry, in any matter within the jurisdiction of any department or agency of the United States, shall be fined not more than \$10,000 or imprisoned for not more than five years, or both.

APPROVED:

United States of America  
Secretary of Housing and Urban Development

By \_\_\_\_\_

(Official Title)

Date \_\_\_\_\_, 19

OWNER WESTSIDE VILLAGE ASSOCIATES

By \_\_\_\_\_

Richard D. Lee - General Partner

(Official Title)

Date February 10, 19 78

HFA VIRGINIA HOUSING DEVELOPMENT AUTHORITY

By \_\_\_\_\_

John Ritchie, Jr. - Executive Director

(Official Title)

Date February 24, 19 78

[If the project is to be completed and accepted in stages, execution of the Contract with respect to the several stages appears on the following pages of this Contract.]

EXECUTION OF CONTRACT WITH RESPECT  
TO CONTRACT UNITS COMPLETED AND ACCEPTED IN STAGES

STAGE 1

This Contract is hereby executed with respect to the units described in Exhibit A-1.

EFFECTIVE DATE: The effective date of this Contract with respect to the units described in Exhibit A-1 is October 3, 19 77.  
[Insert date which shall be no earlier than the date of submission by the HFA to the Government of the certifications required by 24 CFR, Section 883.317(a).] The initial term of this Contract with respect to the units described in Exhibit A-1 shall be 5 years, beginning with the effective date of this Contract with respect to such units and ending October 3, 1982.

APPROVED: OWNER WESTSIDE VILLAGE ASSOCIATES

By [Signature]

- General Partner

(Official Title)

Date February 10, 19 78

HFA VIRGINIA HOUSING DEVELOPMENT AUTHORITY

By [Signature]

John Ritchie, Jr. - Executive Director

(Official Title)

United States of America  
Secretary of Housing and Urban Development

By [Signature]  
Director, Housing Development Division  
(Official Title)

Date March 9, 19 78

Date February 24, 19 78

EXECUTION OF CONTRACT WITH RESPECT  
TO CONTRACT UNITS COMPLETED AND ACCEPTED IN STAGES

STAGE 2

This Contract is hereby executed with respect to the units described in Exhibit A-2.

EFFECTIVE DATE: The effective date of this Contract with respect to the units described in Exhibit A-2 is December 1, 19 77.  
[Insert date which shall be no earlier than the date of submission by the HFA to the Government of the certifications required by 24 CFR, Section 883.317(a).] The initial term of this Contract with respect to the units described in Exhibit A-2 shall be 5 years, beginning with the effective date of this Contract with respect to such units and ending December 1, 1982.

APPROVED: OWNER WESTSIDE VILLAGE ASSOCIATES

By [Signature]

Richard D. Lee - General Partner

(Official Title)

Date February 10, 19 78

HFA VIRGINIA HOUSING DEVELOPMENT AUTHORITY

By [Signature]

John Ritchie, Jr. - Executive Director

(Official Title)

United States of America  
Secretary of Housing and Urban Development

By [Signature]  
Director, Housing Development Division  
(Official Title)

Date March 9, 19 78

Date February 24, 19 78

EXECUTION OF CONTRACT WITH RESPECT  
TO CONTRACT UNITS COMPLETED AND ACCEPTED IN STAGES

STAGE 3

This Contract is hereby executed with respect to the units described in Exhibit A-3.

EFFECTIVE DATE: The effective date of this Contract with respect to the units described in Exhibit A-3 is \_\_\_\_\_, 19 \_\_\_\_.  
[Insert date which shall be no earlier than the date of submission by the HFA to the Government of the certifications required by 24 CFR, Section 883.316(a).]

APPROVED: OWNER \_\_\_\_\_

By \_\_\_\_\_

(Official Title)

Date \_\_\_\_\_, 19 \_\_\_\_

United States of America  
Secretary of Housing and Urban Development

By \_\_\_\_\_  
(Official Title)

Date \_\_\_\_\_, 19 \_\_\_\_

HFA \_\_\_\_\_  
By \_\_\_\_\_  
(Official Title)

Date \_\_\_\_\_, 19 \_\_\_\_

U. S. DEPARTMENT OF HOUSING AND URBAN DEVELOPMENT  
SECTION 8 HOUSING ASSISTANCE PAYMENTS PROGRAM  
HOUSING FINANCE AND DEVELOPMENT AGENCIES

Imp 2  
JES 2/11/76

PART II OF THE  
HOUSING ASSISTANCE PAYMENTS CONTRACT

NEW CONSTRUCTION OR SUBSTANTIAL REHABILITATION

MASTER SECTION 8 ACC NUMBER: P-5512	ACC LIST NUMBER AND DATE: P-77-004 10/29/76	NEW CONSTRUCTION PROJECT NUMBER: VA 36-H027-004
		or SUBSTANTIAL REHABILITATION PROJECT NUMBER:

2.1 NONDISCRIMINATION IN HOUSING.

- a. The Owner shall not in the selection of Families, in the provision of services, or in any other manner, discriminate against any person on the grounds of race, color, creed, religion, sex, or national origin. No person shall be automatically excluded from participation in, or be denied the benefits of, the Housing Assistance Payments Program because of membership in a class such as unmarried mothers, recipients of public assistance, etc.
- b. The Owner shall comply with all requirements imposed by Title VIII of the Civil Rights Act of 1968, and any rules and regulations pursuant thereto.
- c. The Owner shall comply with all requirements imposed by Title VI of the Civil Rights Act of 1964, Public Law 88-352, 78 Stat. 241; the regulations of the Department of Housing and Urban Development issued thereunder, 24 CFR, Subtitle A, Part 1, Section 1.1, et seq.; the requirements of said Department pursuant to said regulations; and Executive Order 11063 to the end that, in accordance with that Act, the regulations and requirements of said Department thereunder, and said Executive Order, no person in the United States shall, on the grounds of race, color, creed, religion or national origin, be excluded from participation in, or be denied the benefits of, the Housing Assistance Payments Program, or be otherwise subjected to discrimination. This provision is included pursuant to the regulations of the Department of Housing and Urban Development, 24 CFR, Subtitle A, Part 1, Section 1.1, et seq.; issued under Title VI of the said Civil Rights Act of 1964, and the requirements of said Department pursuant to said regulations; and the obligation of the Owner to comply therewith inures to the benefit of the Government, the said Department, and the HFA, any of which shall be entitled to invoke any remedies available by law to redress any breach thereof or to compel compliance therewith by the Owner.

2.2 TRAINING, EMPLOYMENT, AND CONTRACTING OPPORTUNITIES FOR BUSINESSES AND LOWER-INCOME PERSONS.<sup>2</sup>

- a. The project assisted under this Contract is subject to the requirements of section 3 of the Housing and Urban Development Act of 1968, as amended, 12 U.S.C. 1701u. Section 3 requires that, to the greatest extent feasible, opportunities for training and employment be given lower-income residents of the project area and contracts for work in connection with the project be awarded to business concerns which are located in, or owned in substantial part by persons residing in, the area of the project.
- b. Notwithstanding any other provision of this Contract, the Owner shall carry out the provisions of said section 3 and the regulations issued pursuant thereto by the Secretary of Housing and Urban Development set forth in 24 CFR, Part 135 (published in 38 Federal Register 29220, October 23, 1973), and all applicable rules and orders of the Secretary issued thereunder prior to the execution of this Contract. The requirements of said regulation include, but are not limited to, development and implementation of an affirmative action plan for utilizing business concerns located within, or owned in substantial part by persons residing in, the area of the project; the making of a good faith effort, as defined by the regulations, to provide training, employment, and business opportunities required by section 3; and incorporation of the "section 3 clause" specified by section 135.20(b) of the regulations and paragraph d of this Section in all contracts for work in connection with the project. The Owner certifies and agrees that he is under no contractual or other disability which would prevent him from complying with these requirements.
- c. Compliance with the provisions of section 3, the regulations set forth in 24 CFR, Part 135, and all applicable rules and orders of the Secretary issued thereunder prior to approval by the Government of the application for this Contract, shall be a condition of the Federal financial assistance provided to the project, binding upon the Owner, his successors and assigns. Failure to fulfill these requirements shall subject the Owner, his contractors and subcontractors, his successors, and assigns to the sanction specified by this Contract, and to such sanctions as are specified by 24 CFR, Section 135.135.
- d. The Owner shall incorporate or cause to be incorporated into any contract or subcontract for work pursuant to this Contract in excess of \$50,000 cost, the following clause:

"EMPLOYMENT OF PROJECT AREA RESIDENTS AND CONTRACTORS

- "A. The work to be performed under this Contract is on a project assisted under a program providing direct Federal financial assistance from the Department of Housing and Urban Development and is subject to the requirements of section 3 of the Housing and Urban Development Act of 1968, as amended, 12 U.S.C. 1701u. Section 3 requires that, to the greatest extent feasible, opportunities for training and employment be given lower-income residents of the project area and contracts for work in connection with the project be awarded to business concerns which are located in, or owned in substantial part by persons residing in, the area of the project.
- "B. The parties to this Contract will comply with the provisions of said section 3 and the regulations issued pursuant thereto by the Secretary of Housing and Urban Development set forth in 24 CFR, Part 135, and all applicable rules and orders of the Department issued thereunder prior to the execution of this Contract. The parties to this Contract certify and agree that they are under no contractual or other disability which would prevent them from complying with these requirements.
- "C. The contractor will send to each labor organization or representative of workers with which he has a collective bargaining agreement or other contract or understanding, if any, a notice advising the said labor organization or workers' representative of his commitments under this section 3 clause and shall post copies of the notice in conspicuous places available to employees and applicants for employment or training.
- "D. The contractor will include this section 3 clause in every subcontract for work in connection with the project and will, at the direction of the applicant for or recipient of Federal financial assistance, take appropriate action pursuant to the subcontract upon a finding that the subcontractor is in violation of regulations issued by the Secretary of Housing and Urban Development, 24 CFR, Part 135. The contractor will not subcontract with any subcontractor where it has notice or knowledge that the latter has been found in violation of regulations under 24 CFR, Part 135, and will not let any subcontract unless the subcontractor has first provided it with a preliminary statement of ability to comply with the requirements of these regulations.

<sup>2</sup>Strike this Section if the Contract Rents on the effective date of this Contract, over the maximum term of this Contract, are \$50,000 or less.

"I. Compliance with the provisions of section 3, the regulations set forth in 24 CFR, Part 135, and all applicable rules and orders of the Department issued thereunder prior to the execution of the Contract, shall be a condition of the Federal financial assistance provided to the project, binding upon the applicant or recipient for such assistance, its successors, and assigns. Failure to fulfill these requirements shall subject the applicant or recipient, its contractors and subcontractors, its successors, and assigns to those sanctions specified by the grant or loan agreement or contract through which Federal assistance is provided, and to such sanctions as are specified by 24 CFR, Section 135.135."

e. The Owner agrees that he will be bound by the above Employment of Project Area Residents and Contractors clause with respect to his own employment practices when he participates in federally assisted work.

2.3 COOPERATION IN EQUAL OPPORTUNITY COMPLIANCE REVIEWS. The HFA and the Owner shall cooperate with the Government in the conducting of compliance reviews and complaint investigations pursuant to all applicable civil rights statutes, Executive Orders, and rules and regulations pursuant thereto.

2.4 FLOOD INSURANCE. If the project is located in an area that has been identified by the Secretary of Housing and Urban Development as an area having special flood hazards and if the sale of flood insurance has been made available under the National Flood Insurance Act of 1968, the Owner agrees that the project will be covered, during its anticipated economic or useful life, by flood insurance in an amount at least equal to its development or project cost (less estimated land cost) or to the maximum limit of coverage made available with respect to the particular type of property under the National Flood Insurance Act of 1968, whichever is less.

2.5 CLEAN AIR ACT AND FEDERAL WATER POLLUTION CONTROL ACT.<sup>3</sup> In compliance with regulations issued by the Environmental Protection Agency ("EPA"), 40 CFR, Part 15, 39 F.R. 11099, pursuant to the Clean Air Act, as amended ("Air Act"), 42 U.S.C. 1857, et seq., the Federal Water Pollution Control Act, as amended ("Water Act"), 33 U.S.C. 1251, et seq., and Executive Order 11738, the Owner agrees that:

- a. Any facility to be utilized in the performance of this Contract or any subcontract shall not be a facility listed on the EPA list of Violating Facilities pursuant to section 15.20 of said regulations;
- b. He will promptly notify the HFA of the receipt of any communication from the EPA indicating that a facility to be utilized for the Contract is under consideration to be listed on the EPA List of Violating Facilities;
- c. He will comply with all the requirements of section 114 of the Air Act and section 308 of the Water Act relating to inspection, monitoring, entry, reports, and information, as well as all other requirements specified in section 114 and section 308 of the Air Act and the Water Act, respectively, and all regulations and guidelines issued thereunder; and
- d. He will include or cause to be included the provisions of this Section in every nonexempt subcontract, and that he will take such action as the Government may direct as a means of enforcing such provisions.

2.6 HFA AND GOVERNMENT ACCESS TO PREMISES AND OWNER'S RECORDS.

- a. The Owner shall furnish such information and reports pertinent to the Contract as reasonably may be required from time to time by the HFA or the Government.
- b. The Owner shall permit the HFA or the Government or any of their duly authorized representatives to have access to the premises and, for the purpose of audit and examination, to have access to any books, documents, papers and records of the Owner that are pertinent to compliance with this Contract, including the verification of information pertinent to the housing assistance payments.

2.7 FAILURE OR INABILITY OF HFA TO COMPLY WITH CONTRACT. The following provisions of the ACC are hereby made a part of this Contract:

"(a) Rights of Owner if HFA Defaults under Contract.

"(1) In the event of failure of the HFA to comply with the Contract with the Owner, or if such Contract is held to be void, voidable or ultra vires, or if the power or right of the HFA to enter into such Contract is drawn into question in any legal proceeding, or if the HFA asserts or claims that such Contract is not binding upon the HFA for any such reason, the Government may, after notice to the HFA giving it a reasonable opportunity to take corrective action, determine that the occurrence of any such event constitutes a Substantial Default hereunder. Where the Government so determines, it shall have the right to assume the HFA's rights and obligations under such Contract, perform the obligations and enforce the rights of the HFA, and exercise such other powers as the Government may have to cure the Default; however, whether or not the Government elects to proceed in this manner, the Government shall, if it determines that the Owner is not in default, continue for the duration of such Contract to pay Annual Contributions for the purpose of making housing assistance payments with respect to dwelling units under such Contract.

"(2) All rights and obligations of the HFA assumed by the Government pursuant to this Section 2.16(a) will be returned as constituted at the time of such return (i) when the Government is satisfied that all defaults have been cured and that the Project will thereafter be administered in accordance with all applicable requirements, or (ii) when the Housing Assistance Payments Contract is at an end, whichever occurs sooner.

"(3) The provisions of this Section 2.16(a) are made with, and for the benefit of, the Owner, the HFA (but only in its capacity as lender), or the Owner's other assignees, if any, who will have been specifically approved by the Government prior to such assignment. If such parties are not in default, they may, in order to enforce the performance of these provisions, (i) demand that the Government, after notice to the HFA giving it a reasonable opportunity to take corrective action, make a determination whether a Substantial Default exists under paragraph (a)(1) of this Section, (ii) if the Government determines that a Substantial Default exists, demand that the Government take action as authorized in paragraph (a)(1), and (iii) proceed against the Government by suit at law or in equity."

2.8 RIGHTS OF HFA AND GOVERNMENT IF OWNER DEFAULTS UNDER CONTRACT.

a. A default by the Owner under this Contract shall result if:

- (1) The Owner has violated or failed to comply with any provision of, or obligation under, this Contract or of any Lease; or
- (2) The Owner has asserted or demonstrated an intention not to perform some or all of his obligations under this Contract or under any Lease.

b. Upon a determination by the HFA that a default has occurred, the HFA shall notify the Owner, with a copy to the Government, of (1) the nature of the default, (2) the actions required to be taken and the remedies to be applied on account of the default (including actions by the Owner to cure the default, and, where appropriate, abatement of housing assistance payments in whole or in part and recovery of over-payments), and (3) the time within which the Owner shall respond with a showing that he has taken all the actions required of him. If the Owner fails to respond or take action to the satisfaction of the HFA and the Government, the HFA shall have the right to terminate this Contract in whole or in part or to take other corrective action to achieve compliance, in its discretion or as directed by the Government.

<sup>3</sup>Strike this Section if the Contract Rents on the effective date of this Contract, over the maximum total term of this Contract, are \$100,000 or less.

v. Notwithstanding any other provisions of this Contract, in the event the Government determines that the Owner is in default of his obligations under the Contract, the Government shall have the right, after notice to the Owner and the HFA giving them a reasonable opportunity to take corrective action, to abate or terminate housing assistance payments and recover overpayments in accordance with the terms of the Contract. In the event the Government takes any action under this Section, the Owner and the HFA hereby expressly agree to recognize the rights of the Government to the same extent as if the action were taken by the HFA. The Government shall not have the right to terminate the Contract except by proceeding in accordance with Section 2.16(b) of the ACC and paragraph b of this Section.

2.9 REMEDY NOT EXCLUSIVE AND NON-WAIVER OF REMEDIES The availability of any remedy under this Contract or the ACC shall not preclude the exercise of any other remedy under this Contract or the ACC or under any provision of Law, nor shall any action taken in the exercise of any remedy be deemed a waiver of any other rights or remedies. Failure to exercise any right or remedy shall not constitute a waiver of the right to exercise that or any other right or remedy at any time.

2.10 DISPUTES

- a. Except as otherwise provided herein, any dispute concerning a question of fact arising under this Contract which is not disposed of by agreement of the HFA and the Owner may be submitted by either party to the Department of Housing and Urban Development field office director who shall make a decision and shall mail or otherwise furnish a written copy thereof to the Owner and the HFA.
- b. The decision of the field office director shall be final and conclusive unless, within 30 days from the date of receipt of such copy, either party mails or otherwise furnishes to the Government a written appeal addressed to the Secretary of Housing and Urban Development. The decision of the Secretary or duly authorized representative for the determination of such appeals shall be final and conclusive, unless determined by a court of competent jurisdiction to have been fraudulent, or capricious, or arbitrary, or so grossly erroneous as necessarily to imply bad faith, or not supported by substantial evidence. In connection with any appeal proceeding under this Section, the appellant shall be afforded an opportunity to be heard and to offer evidence in support of his appeal. Pending final decision of a dispute hereunder, both parties shall proceed diligently with the performance of the Contract and in accordance with the decision of the field office director.
- c. This Section does not preclude consideration of questions of law in connection with the decisions rendered under paragraphs a and b of this Section; provided, however, that nothing herein shall be construed as making final the decision of any administrative official, representative, or board, on a question of law.

2.11 INTEREST OF MEMBERS, OFFICERS, OR EMPLOYEES OF HFA, MEMBERS OF LOCAL GOVERNING BODY OR OTHER PUBLIC OFFICIALS. No member, officer, or employee of the HFA, no member of the governing body of the State or locality (city and county) in which the project is situated, and no other public official of such State or locality who exercises any functions or responsibilities with respect to the project, during his tenure or for one year thereafter, shall have any interest, direct or indirect, in this Contract or in any proceeds or any benefits arising therefrom. In the case of a project owned by a public housing agency, the foregoing prohibition shall also apply to members of the governing body of the locality (city and county) in which such public housing agency was activated.

2.12 INTEREST OF MEMBER OF OR DELEGATE TO CONGRESS. No member of or delegate to the Congress of the United States of America or resident commissioner shall be admitted to any share or part of this Contract or to any benefits which may arise therefrom.

2.13 ASSIGNMENT, SALE, OR FORECLOSURE

- a. The Owner agrees that he has not made and will not make any sale, assignment, or conveyance or transfer in any other form, of this Contract or the project or any part thereof or any of his interest therein, without the prior consent of the HFA and the Government; Provided, however, that in the case of an assignment as security for the purpose of obtaining financing of the project, the HFA and the Government shall consent in writing if the terms of the financing have been approved by the Government.
- b. The Owner agrees to notify the HFA and the Government promptly of any proposed action covered by paragraph a of this Section. The Owner further agrees to request the written consent of the HFA and the Government in regard thereto.
- c. (1) A transfer by the Owner, in whole or in part, or a transfer by a party having a substantial interest in said Owner, or transfers by more than one party of interests aggregating a substantial interest in said Owner, or any other similarly significant change in the ownership of interests in the Owner, or in the relative distribution thereof, or with respect to the parties in control of the Owner or the degree thereof, by any other method or means (e.g., increased capitalization, merger with another corporation or other entity, corporate or other amendments, issuance of new or additional ownership interests or classification of ownership interests or otherwise) shall be deemed an assignment, conveyance, or transfer for purposes of this Section 2.13. An assignment by the Owner to a limited partnership, in which no limited partner has a 25 percent or more interest and of which the Owner is the sole general partner, shall not be considered an assignment, conveyance, or transfer.  
(2) The term "substantial interest" means the interest of any general partner, any limited partner having a 25 percent or more interest in the organization, any corporate officer or director, and any stockholder having a 10 percent or more interest in the organization.  
(3) The Owner, and the party signing this Contract on behalf of said Owner, represent that they have the authority of all of the parties having ownership interests in the Owner to agree to this provision on their behalf and to bind them with respect thereto.
- d. In the event of foreclosure, or assignment or sale to the HFA (or mortgagee if the HFA is not the mortgagee) in lieu of foreclosure, or in the event of assignment or sale agreed to by the HFA (or mortgagee if the HFA is not the mortgagee) and approved by the Government (which approval shall not be unreasonably delayed or withheld), housing assistance payments shall continue in accordance with the terms of the Contract.



EXHIBIT A-1

Stage

1

Units

16 2 BR

4 3 BR

EXHIBIT A-2

Stage

2

Units

8 1 BR

18 2 BR

18 3 BR

6 4 BR

**NOTIFICATION OF SECTION 8 CONTRACT RENTS AND FUNDING**

FOR (Check one):

- Initial Renewal       Subsequent Renewal  
 Amend Rent/BA Only       Short-Term Renewal

Section 8 Contract No. VAB6H027004 Expires on 11/30/2037

Owner Name: NEW WESTSIDE VILLAGE I LIMITED PARTNERSHIP

Project Name: WESTSIDE VILLAGE

Project Location: 2150 SINAI ROAD #18, SOUTH BOSTON, VA 24592

FHA Project No.: N/A

**IDENTIFICATION OF UNITS ("CONTRACT UNITS") BY SIZE  
AND APPLICABLE CONTRACT RENTS**

Rent Effective Date

(If blank then no change in rents.)

No. of Units	No. of Bedrooms	Contract Rent	Utility Allowance	Gross Rent
<u>8</u>	<u>1 BR</u>	<u>\$ 463</u>	<u>\$ 62</u>	<u>\$ 525</u>
<u>34</u>	<u>2 BR</u>	<u>\$ 540</u>	<u>\$ 95</u>	<u>\$ 635</u>
<u>22</u>	<u>3 BR</u>	<u>\$ 704</u>	<u>\$ 113</u>	<u>\$ 817</u>
<u>6</u>	<u>4 BR</u>	<u>\$ 745</u>	<u>\$ 135</u>	<u>\$ 880</u>

FUNDING

\$490,440 <sup>with</sup> 3/26/18

BUDGET AUTHORITY INCREASE: \$ 588,524

Contract/Renewal Effective Date 12/1/2017 Expiration Date 11/30/2037

For HUD Use Only: THE ANNUAL COMMITMENT AMOUNT IS NOT WHAT'S REFLECTING IN LOSSES. THE LOSSES AMOUNT HAS BEEN RECORDED ABOVE. rdk

Notice to Owner executed by:  
HUD or CONTRACT ADMINISTRATOR

By: \_\_\_\_\_ (Signature)

Robert S. Ford (Printed Name)

Chief (Official Title)

2/22/18 (Date)

U.S. Department of Housing and Urban Development  
Office of Housing

**Project-based Section 8**  
**HOUSING ASSISTANCE PAYMENTS**  
**BASIC RENEWAL CONTRACT**  
**MULTI-YEAR TERM**

OMB Control #2502-0547

"Public reporting burden for this collection of information is estimated to average 1 hour. This includes the time for collecting, reviewing, and reporting the data. The information is being collected for obtaining a signature on legally binding documents and will be used to enforce contractual obligations. Response to this request for information is required in order to receive the benefits to be derived. This agency may not collect this information, and you are not required to complete this form unless it has a currently valid OMB control number. No confidentiality is assured."

**PREPARATION OF CONTRACT**

Reference numbers in this form refer to notes at the end of the contract text. These endnotes are instructions for preparation of the Basic Renewal Contract. The instructions are not part of the Renewal Contract

DUHS # 961704256  
(HUD-9637)

Basic Renewal Contract  
Multi-Year Term  
REV-11-05-2007

## TABLE OF SECTIONS

<b>1 CONTRACT INFORMATION</b>	<b>1</b>
<b>PROJECT</b>	<b>1</b>
<b>TYPE OF RENEWAL</b>	<b>1</b>
<b>2 TERM AND FUNDING OF RENEWAL CONTRACT</b>	<b>2</b>
<b>3 DEFINITIONS</b>	<b>3</b>
<b>4 RENEWAL CONTRACT</b>	<b>4</b>
<b>a Parties</b>	<b>4</b>
<b>b Statutory authority</b>	<b>4</b>
<b>c Expiring Contract</b>	<b>5</b>
<b>d Purpose of Renewal Contract</b>	<b>5</b>
<b>e Contract units</b>	<b>5</b>
<b>5 EXPIRING CONTRACT – PROVISIONS RENEWED</b>	<b>5</b>
<b>6 CONTRACT RENT</b>	<b>6</b>
<b>a Initial contract rents</b>	<b>6</b>
<b>b Contract rent adjustments</b>	<b>6</b>
<b>(1) OCAF or Budget-Based Rent Adjustments</b>	<b>6</b>
<b>(2) Comparability adjustments</b>	<b>7</b>
<b>(a) Applicability</b>	<b>7</b>
<b>(b) Fifth year adjustment (comparability adjustment at expiration of each 5-year period, if applicable)</b>	<b>7</b>

	Attachment 11-2
<b>(c) Mid-term adjustment (discretionary comparability adjustment within 5-year term)</b>	<b>8</b>
<b>(d) Adjusting contract rent</b>	<b>8</b>
<b>(3) Procedure for rent adjustments during renewal term</b>	<b>8</b>
<b>(4) No other adjustments</b>	<b>9</b>
<b>7 OWNER WARRANTIES</b>	<b>9</b>
<b>8 OWNER TERMINATION NOTICE</b>	<b>9</b>
<b>9 HUD REQUIREMENTS</b>	<b>9</b>
<b>10 STATUTORY CHANGES DURING TERM</b>	<b>10</b>
<b>11 PHA DEFAULT</b>	<b>10</b>
<b>12 EXCLUSION OF THIRD-PARTY RIGHTS</b>	<b>10</b>
<b>13 WRITTEN NOTICES</b>	<b>11</b>
<b>SIGNATURES</b>	<b>12</b>

U.S. Department of Housing and Urban Development  
Office of Housing

Project-based Section 8

HOUSING ASSISTANCE PAYMENTS

BASIC RENEWAL CONTRACT<sup>1</sup>

MULTI-YEAR TERM

1 CONTRACT INFORMATION<sup>2</sup>

PROJECT

Section 8 Project Number: VA36H027004

Section 8 Project Number of Expiring Contract: VA38H027004

FHA Project Number (if applicable): NA

Project Name: WESTSIDE VILLAGE

Project Description:

2150 SINAI ROAD, SOUTH BOSTON, HALIFAX COUNTY, VIRGINIA

TYPE OF RENEWAL

Check this box for a project renewed under Section 524(a) of MAHRA (not including a Mark-Up-To-Market renewal).

Check this box for a project renewed at exception rents under Section 524(b)(1) of MAHRA.

**PARTIES TO RENEWAL CONTRACT**

**Name of Contract Administrator<sup>4</sup>**  
US DEPARTMENT OF HOUSING AND URBAN  
DEVELOPMENT

---

**Address of Contract Administrator**

600 EAST BROAD STREET  
RICHMOND, VA 23219

---

**Name of Owner<sup>5</sup>**  
NEW WESTSIDE VILLAGE I LIMITED PARTNERSHIP

---

**Address of Owner**

1375 PICCARD DRIVE #150  
ROCKVILLE, MD 20850

---

**2 TERM AND FUNDING OF RENEWAL CONTRACT**

**a** The Renewal Contract begins on 12/01/2017<sup>6</sup> and shall run for a period of 20<sup>7</sup> years.

**b** Execution of the Renewal Contract by the Contract Administrator is an obligation by HUD of \$ 588,524<sup>8</sup>, an amount sufficient to



---

provide housing assistance payments for approximately \_\_\_\_\_<sup>6</sup> months of the first annual increment of the Renewal Contract term.

- c** HUD will provide additional funding for the remainder of the first annual increment and for subsequent annual increments, including for any remainder of such subsequent annual increments, subject to the availability of sufficient appropriations. When such appropriations are available, HUD will obligate additional funding and provide the Owner written notification of (i) the amount of such additional funding, and (ii) the approximate period of time within the Renewal Contract term to which it will be applied.

**3 DEFINITIONS**

**ACC.** Annual contributions contract.

**Anniversary.** The annual recurrence of the date of the first day of the term of the Renewal Contract.

**Contract rent.** The total monthly rent to owner for a contract unit, including the tenant rent (the portion of rent to owner paid by the assisted family).

**Contract units.** The units in the Project which are identified in Exhibit A by size and applicable contract rents.

**Fifth year anniversary.** The Renewal Contract annual anniversary that falls at expiration of each 5-year period of the Renewal Contract term.

**Fifth year comparability adjustment.** An adjustment of contract rents by the contract administrator at the Fifth Year Anniversary. The contract rent for each unit size is set at comparable rent as shown by comparability analysis.

**HAP contract.** A housing assistance payments contract between the Contract Administrator and the Owner.

**HUD.** The United States Department of Housing and Urban Development.

**HUD requirements.** HUD regulations and other requirements, including changes in HUD regulations and other requirements during the term of the Renewal Contract.

**MAHRA.** The Multifamily Assisted Housing Reform and Affordability Act of 1997 (Title V of Public Law No.105-65, October 27, 1997, 111 Stat. 1384), as amended.

**Mid-term comparability adjustment.** An adjustment of contract rents by the contract administrator within each 5-year period of the Renewal Contract term (in addition to the comparability analysis and adjustment at the Fifth Year Anniversary). The contract rent for each unit size is set at comparable rent as shown by comparability analysis.

**OCAF.** An operating cost adjustment factor established by HUD.

**PHA.** Public housing agency (as defined and qualified in accordance with the United States Housing Act of 1937, 42 U.S.C. 1437 et seq.).

**Project.** The housing described in section 1 of the Renewal Contract.

**Renewal Contract.** This contract, including applicable provisions of the Expiring Contract (as determined in accordance with section 5 of the Renewal Contract).

**Section 8.** Section 8 of the United States Housing Act of 1937 (42 U.S.C. 1437f).

#### 4 RENEWAL CONTRACT

##### a Parties

- (1) The Renewal Contract is a housing assistance payments contract ("HAP Contract") between the Contract Administrator and the Owner of the Project (see section 1).
- (2) If HUD is the Contract Administrator, HUD may assign the Renewal Contract to a public housing agency ("PHA") for the purpose of PHA administration of the Renewal Contract, as Contract Administrator, in accordance with the Renewal Contract (during the term of the annual contributions contract ("ACC") between HUD and the PHA). Notwithstanding such assignment, HUD shall remain a party to the provisions of the Renewal Contract that specify HUD's role pursuant to the Renewal Contract, including such provisions of section 9 (HUD requirements), section 10 (statutory changes during term) and section 11 (PHA default), of the Renewal Contract.

##### b Statutory authority

The Renewal Contract is entered pursuant to section 8 of the United States Housing Act of 1937 (42 U.S.C. 1437f), and section 524 of MAHRA.

---

**c Expiring Contract**

Previously, the Contract Administrator and the Owner had entered into a HAP Contract ("expiring contract") to make Section 8 housing assistance payments to the Owner for eligible families living in the Project. The term of the expiring contract will expire prior to the beginning of the term of the Renewal Contract.

**d Purpose of Renewal Contract**

- (1) The purpose of the Renewal Contract is to renew the expiring contract for an additional term. During the term of the Renewal Contract, the Contract Administrator shall make housing assistance payments to the Owner in accordance with the provisions of the Renewal Contract.
- (2) Housing assistance payments shall only be paid to the Owner for contract units occupied by eligible families leasing decent, safe and sanitary units from the Owner in accordance with statutory requirements, and with all HUD regulations and other requirements. If the Contract Administrator determines that the Owner has failed to maintain one or more contract units in decent, safe and sanitary condition, and has abated housing assistance payments to the Owner for such units, the Contract Administrator may use amounts otherwise payable to the Owner pursuant to the Renewal Contract for the purpose of relocating or rehousing assisted residents in other housing.

**e Contract units**

The Renewal Contract applies to the Contract units.

**5 EXPIRING CONTRACT -- PROVISIONS RENEWED**

- a** Except as specifically modified by the Renewal Contract, all provisions of the Expiring Contract are renewed (to the extent such provisions are consistent with statutory requirements in effect at the beginning of the Renewal Contract term).
- b** All provisions of the Expiring Contract concerning any of the following subjects are not renewed, and shall not be applicable during the renewal term:

- (1) Identification of contract units by size and applicable contract rents;
  - (2) The amount of the monthly contract rents;
  - (3) Contract rent adjustments; and
  - (4) Project account (sometimes called "HAP reserve" or "project reserve") as previously established and maintained by HUD pursuant to former Section 8(c)(6) of the United States Housing Act of 1937 (currently Section 8(c)(5) of the Act, 42 U.S.C. 1437f(c)(5)). Section 8(c)(5) does not apply to the Renewal Contract, or to payment of housing assistance payments during the Renewal Contract term.
- c The Renewal Contract includes those provisions of the Expiring Contract that are renewed in accordance with this section 5.

**6 CONTRACT RENT**

**a Initial contract rents**

At the beginning of the Renewal Contract term, and until contract rents for units in the Project are adjusted in accordance with section 6b, the contract rent for each bedroom size (number of bedrooms) shall be the initial contract rent amount listed in Exhibit A of the Renewal Contract.

**b Contract rent adjustments**

**(1) OCAF or Budget-Based Rent Adjustments**

- (a) Except as provided in section 6b(2) below (concerning comparability adjustments at each Fifth Year Anniversary and discretionary comparability adjustments within each five-year term), during the term of the Renewal Contract the Contract Administrator shall annually, on the anniversary of the Renewal Contract, adjust the amounts of the monthly contract rents in accordance with HUD requirements by either of the following methods (as determined by the Contract Administrator in accordance with HUD requirements):

- (i) Using an OCAF; or

---

(ii) At the request of the owner, based on the budget for the Project, as approved by the Contract Administrator in accordance with HUD requirements.

(b) Adjustments by use of the OCAF shall not result in a negative adjustment (decrease) of the contract rents. The OCAF shall not be used for adjustment of rent at each Fifth Year Anniversary (as determined in accordance with section 6b(2)(b) below).

**(2) Comparability adjustments**

(a) **Applicability.** This section 6b(2) is applicable only if the contract has been renewed pursuant to Section 524(a) of MAHRA. This section 6b(2) does not apply to a project renewed at exception rents under Section 524(b)(1) of MAHRA (See section 1 of the Renewal Contract).

(b) **Fifth year adjustment (comparability adjustment at expiration of each 5-year period, if applicable).**

(i) This section 6b(2)(b) is only applicable if the term of the Renewal Contract is longer than five (5) years (from the first day of the term specified in section 2a).

(ii) At the expiration of each 5-year period of the Renewal Contract term ("Fifth Year Anniversary"), the Contract Administrator shall conduct a comparability analysis of existing contract rents. At such Fifth Year Anniversary of the Renewal Contract, the Contract Administrator shall make any adjustments in the monthly contract rents, as reasonably determined by the Contract Administrator in accordance with HUD requirements, necessary to set the contract rent for each unit size at comparable market rent. Such adjustment may result in a negative adjustment (decrease) or positive adjustment (increase) of the contract rents for one or more unit sizes.

(iii) To assist in the redetermination of contract rents at each Fifth Year Anniversary, the

---

Contract Administrator may require that the Owner submit to the Contract Administrator a rent comparability study prepared (at the Owner's expense) in accordance with HUD requirements.

**(c) Mid-term adjustment (discretionary comparability adjustment within 5-year term)**

In addition to the comparability analysis and adjustment of contract rents at the Fifth Year Anniversary, HUD may, at HUD's discretion, require or permit the Contract Administrator to conduct a comparability analysis and adjustment of contract rents ("mid-term adjustment"), one more time within each 5-year period of the Renewal Contract term

**(d) Adjusting contract rent**

At the time of a fifth year or mid-term comparability adjustment, the Contract Administrator shall make any adjustments in the monthly contract rents, as reasonably determined by the Contract Administrator in accordance with HUD requirements, necessary to set the contract rent for each unit size at comparable rent. Such adjustment may result in a negative adjustment (decrease) or positive adjustment (increase) of the contract rents for one or more unit sizes.

**(3) Procedure for rent adjustments during renewal term**

**(a)** To adjust contract rents during the term of the Renewal Contract (including an OCAF or budget-based adjustment in accordance with section 6b(1), or a fifth year or midterm adjustment in accordance with section 6b(2)), the Contract Administrator shall give the Owner notice with a revised Exhibit A that specifies the adjusted contract rent amounts.

**(b)** The revised Exhibit A shall specify the adjusted contract rent amount for each bedroom size as determined by the Contract Administrator in accordance with this section. The adjustment notice by the Contract Administrator to the Owner shall

---

specify when the adjustment of contract rent is effective.

- (c) Notice of rent adjustment by the Contract Administrator to the Owner shall automatically constitute an amendment of the Renewal Contract.

**(4) No other adjustments**

Except for contract rent adjustments in accordance with this section, there shall not be any other adjustments of the contract rents during the term of the Renewal Contract. Special adjustments shall not be granted.

**7 OWNER WARRANTIES**

- a The Owner warrants that it has the legal right to execute the Renewal Contract and to lease dwelling units covered by the contract.
- b The Owner warrants that the rental units to be leased by the Owner under the Renewal Contract are in decent, safe and sanitary condition (as defined and determined in accordance with HUD regulations and procedures), and shall be maintained in such condition during the term of the Renewal Contract.

**8 OWNER TERMINATION NOTICE**

- a Before termination of the Renewal Contract, the Owner shall provide written notice to the Contract Administrator and each assisted family in accordance with HUD requirements.
- b If the Owner fails to provide such notice in accordance with the law and HUD requirements, the Owner may not increase the tenant rent payment for any assisted family until such time as the Owner has provided such notice for the required period.

**9 HUD REQUIREMENTS**

The Renewal Contract shall be construed and administered in accordance with all statutory requirements, and with all HUD regulations and other requirements, including changes in HUD regulations and other requirements during the term of the Renewal Contract. However, any changes in HUD requirements that are inconsistent with the provisions of the Renewal Contract, including the provisions of section 6 (contract rent), shall not be applicable.

---

**10 STATUTORY CHANGES DURING TERM**

If any statutory change during the term of the Renewal Contract is inconsistent with section 6 of the Renewal Contract, and if HUD determines, and so notifies the Contract Administrator and the Owner, that the Contract Administrator is unable to carry out the provisions of section 6 because of such statutory change, then the Contract Administrator or the Owner may terminate the Renewal Contract upon notice to the other party.

**11 PHA DEFAULT**

- a This section 11 of the Renewal Contract applies if the Contract Administrator is a PHA acting as Contract Administrator pursuant to an annual contributions contract ("ACC") between the PHA and HUD. This includes a case where HUD has assigned the Renewal Contract to a PHA Contract Administrator, for the purpose of PHA administration of the Renewal Contract.
- b If HUD determines that the PHA has committed a material and substantial breach of the PHA's obligation, as Contract Administrator, to make housing assistance payments to the Owner in accordance with the provisions of the Renewal Contract, and that the Owner is not in default of its obligations under the Renewal Contract, HUD shall take any action HUD determines necessary for the continuation of housing assistance payments to the Owner in accordance with the Renewal Contract.

**12 EXCLUSION OF THIRD-PARTY RIGHTS**

- a The Contract Administrator does not assume any responsibility for injury to, or any liability to, any person injured as a result of the Owner's action or failure to act in connection with the Contract Administrator's implementation of the Renewal Contract, or as a result of any other action or failure to act by the Owner.
- b The Owner is not the agent of the Contract Administrator or HUD, and the Renewal Contract does not create or affect any relationship between the Contract Administrator or HUD and any lender to the Owner or any suppliers, employees, contractors or subcontractors used by the Owner in connection with implementation of the Renewal Contract.
- c If the Contract Administrator is a PHA acting as Contract Administrator pursuant to an annual contributions contract ("ACC") between the PHA and HUD, the Contract Administrator is not the



---

agent of HUD, and the Renewal Contract does not create any relationship between HUD and any suppliers, employees, contractors or subcontractors used by the Contract Administrator to carry out functions or responsibilities in connection with contract administration under the ACC.

**13 WRITTEN NOTICES**

- a** Any notice by the Contract Administrator or the Owner to the other party pursuant to the Renewal Contract shall be given in writing.
- b** A party shall give notice at the other party's address specified in section 1 of the Renewal Contract, or at such other address as the other party has designated by a contract notice. A party gives a notice to the other party by taking steps reasonably required to deliver the notice in ordinary course of business. A party receives notice when the notice is duly delivered at the party's designated address.

**SIGNATURES**

**Contract administrator (HUD or PHA)  
Name of Contract Administrator**

N/A

By: \_\_\_\_\_

Signature of authorized representative

Name and official title

Date \_\_\_\_\_

U.S. Department of Housing and Urban Development

By: Brenda J. Brown

Signature of authorized representative Brenda J. Brown, Director

Asset Management Division

Name and official title

Date 3/26/2018

Owner  
Name of Owner

NEW WESTSIDE VILLAGE I LIMITED PARTNERSHIP

By: Robert Margolis

Signature of authorized representative

Robert Margolis, CR

Name and title

Date 2/26/18



**EXHIBIT B**  
**DISTRIBUTIONS LIMITATION**

**FOR PROJECT NOT SUBJECT TO DISTRIBUTIONS LIMITATION:**

If the project is not subject to any limitation on distributions of project funds, either pursuant to an FHA Regulatory Agreement or pursuant to the Expiring Contract, neither HUD nor the PHA may impose any additional limitation on distributions of project funds during the term of the Renewal Contract.

**FOR PROJECT SUBJECT TO DISTRIBUTIONS LIMITATION:**

If the project is subject to any limitation on distributions of project funds pursuant to an FHA Regulatory Agreement or pursuant to the Expiring Contract, such limitation on distributions shall continue to be applicable during the term of the Renewal Contract, provided that the owner may take an increased distribution in accordance with the Section 8 Renewal Policy Guidance for Renewal of Project-Based Section 8 Contracts, (the "Guidebook").

However, owners of Section 8 properties must maintain the property in good condition, as demonstrated by a REAC score of 60 or higher, in order to take increased distributions.

The owner shall comply with the distribution limitations. The maximum distribution to the owner shall be equal to the total of:

- 1 The limited distribution permitted pursuant to the FHA Regulatory agreement or the Expiring Contract, plus
- 2 Any increased distribution as approved by HUD in accordance with the Guidebook.

## INSTRUCTIONS FOR PREPARATION OF RENEWAL CONTRACT

The following instructions are not part of the Renewal Contract.

Endnote numbers are keyed to references in the text of the Renewal Contract.

<sup>1</sup> This form of Renewal Contract is to be used for initial and subsequent renewals of an expiring Section 8 project-based HAP contract under the authority of Section 524(a) or 524(b)(1) of MAHRA for a term of two years or more. Attachment 11-1 is to be used for renewals under the authority of Section 524(a) or 524(b)(1) of MAHRA for a renewal term of one year.

This form may not be used for Mark-Up-To-Market Renewals. The HUD prescribed form of Mark-Up-To-Market Renewal Contract must be used for this purpose.

Section 2 of the Renewal Contract specifies the contract term.

<sup>2</sup> To prepare the Renewal Contract for execution by the parties, fill out all contract information in section 1 and section 2.

<sup>3</sup> Enter a description of housing that will be covered by the Renewal Contract. The description must clearly identify the Project by providing the Project's name, street address, city, county, state, and zip code, block and lot number (if known), and any other information, necessary to clearly designate the covered Project.

<sup>4</sup> Enter the name of the Contract Administrator that executes the Renewal Contract. If HUD is the Contract Administrator, enter "United States of America – Department of Housing and Urban Development (HUD)". If the Contract Administrator is a public housing agency ("PHA"), enter the full legal name of the PHA.

<sup>5</sup> Enter the full legal name of the Owner. For example: "ABC Corporation, Inc., a Maryland corporation."

<sup>6</sup> The Renewal Contract must be entered before expiration of the Expiring Contract. Enter the date of the first day after expiration of the term of the Expiring Contract.

<sup>7</sup> Enter a whole number of two or more years.

<sup>8</sup> Enter the amount of funding obligated.

<sup>9</sup> Enter a whole number of months.



**Part G - Information on Mortgagor Entity**

Name of Entity

New Westside Village I Limited Partnership

Type of Entity

- Individual   
  General Partnership   
  Joint Tenancy/Tenants in Common   
  Other (specify) \_\_\_\_\_  
 Corporation   
 Limited Partnership   
 Trust

List all Principals Comprising Mortgagor Entity; provide name and title of each principal. Use extra sheets, if needed. If mortgagor is a:  
 • corporation, list: (1) all officers; (2) all directors; and (3) each stockholder having a 10% or more interest.  
 • partnership, list: (1) all general partners; and (2) limited partners having a 25% or more interest in the partnership.  
 • trust, list: (1) all managers, directors or trustees and (2) each beneficiary having at least a 10% beneficial interest in the trust.

Name and Title

Name and Title

Name and Title

Name and Title

Name and Title

Name and Title

Name and Title

Name and Title

Name and Title

Name and Title

Name and Title

**Part H - Owner Certification**

To the best of my knowledge, all the information stated herein, as well as any information provided in the accompaniment herewith, is true and accurate.  
**Warning: HUD will prosecute false claims and statements. Conviction may result in criminal and/or civil penalties (18 U.S.C. 1001, 1010, 1012; 31 U.S.C. 3729, 3802)**

Name and Title

Robert Margolis, Managing Member  
 New Westside Village I, LP

Authorized Official's Signature



2/26/15  
 Date (mm/dd/yyyy)

**Part I - HUD/Lender Approval**

Addendum Number

Branch Chief/Lender Official Signature

HAP Contract Number

Date (mm/dd/yyyy)

Exhibit Number

Director, Housing Management Division Signature

Loan Servicer Signature

Date (mm/dd/yyyy)

Date (mm/dd/yyyy)



Public reporting burden for this collection of information is estimated to average 20 minutes per response, including the time for reviewing instructions, searching existing data sources, gathering and maintaining the data needed, and completing and reviewing the collection of information. This agency may not collect this information, and you are not required to complete this form, unless it displays a currently valid OMB control number.

This collection of information is authorized under Section 207 of the National Housing Act. The information is necessary for the Department to ensure that project owners are not overcharging their tenants and to ensure that the rent levels approved by the Department are not exceeded. The Department uses this information to enforce rent regulations which otherwise would be difficult because there would be no clear record of the rents and charges that the Department had approved. In addition, the Department needs to periodically collect information regarding project principals, so unauthorized participation by previously excluded or otherwise undesirable owners can be detected. This information is required to obtain benefits. HUD may disclose certain information to Federal, State, and local agencies when relevant to civil, criminal, or regulatory investigations and prosecutions. It will not be otherwise disclosed or released outside of HUD, except as required and permitted by law.

### Instructions

All project owners must submit the form HUD-92458 when requesting an adjustment to project rents. HUD establishes and approves rental charges and utility allowances on the Form. The owner is responsible for notifying tenants of the approved rents.

**General.** For projects with fully-insured or HUD-held mortgages, the owner/agent submits this Form to the HUD Field Office. For projects with coinsured mortgages, the owner/agent submits this Form to the lender.

**Part A.** If the monthly rent potential you are proposing is less than or equal to the Maximum Allowable Monthly Rent Potential approved by HUD/lender on your original Rent Formula or on your most recent Rent Computation Worksheet, complete all of Part A according to the instructions below. If the monthly rent potential you are requesting exceeds the Maximum Allowable Monthly Rent Potential approved by HUD/lender on your original Rent Formula or on your most recent Rent Computation Worksheet, complete only Columns 1 and 2 according to the instructions below. Show your proposed rents and monthly rent potential in the cover letter transmitting your rent increase request.

**Column 1.** Show each type of unit for which rents will vary. Show the number of bedrooms and bathrooms and other features that cause rents to vary (e.g., 2 BDM, 1 B, DA, KETTE, vs 2 BDM, 2B, DR, K). Use the following symbols:

BDM	- Bedroom	LR	- Living Room
B	- Bath	DR	- Dining Room
K	- Kitchen	DA	- Dining Alcove
KETTE	- Kitchenette		

**Column 2.** Show the number of units for each unit type. Include non-revenue producing units.

**Column 3.** For unsubsidized projects, show the rent you intend to charge for each unit type. For subsidized projects, show the contract rent (as defined in HUD Handbook 4350.3) for each unit type.

**Column 4.** For each line, multiply the contract rent in Column 3 by the number of units in Column 2. Add monthly contract rent potentials for each unit size to compute the total monthly contract rent potential. Multiply the monthly total by 12 to compute the annual contract rent potential.

**Columns 5 and 6.** Complete the Columns only if the project has a subsidy contract with HUD and some utilities are not included in the rent. In Column 5, show the utility allowance for each unit type. Compute the gross rent for each unit type by adding the contract rent in Column 3 and the utility allowance in Column 5. Show this amount in Column 6.

**Columns 7 and 8.** Complete these Columns only if the project is receiving Section 236 Interest Reduction Payments. In Column 7, show the market rent for each unit type. In Column 8, for each line multiply the market rent in Column 7 by the number of units in Column 2. Add the monthly market rent potentials for each unit size to compute the total monthly market rent potential. Multiply the monthly total by 12 to compute the annual market rent potential.

**Parts B, C, D and E.** Complete these Parts according to the instructions on the Rent Schedule.

**Part F.** Do not complete this Part. The HUD Field Office/lender will complete this Part.

**Parts G and H.** Complete these Parts according to the instructions on the Rent Schedule.

**Part I.** Do not complete this Part. The HUD Field Office/lender will complete this part.

R

Documentation of  
Operating Budget



**Part G – Information on Mortgagor Entity**

Name of Entity

New Westside Village I Limited Partnership

Type of Entity

- Individual     General Partnership     Joint Tenancy/Tenants in Common     Other (specify)  
 Corporation     Limited Partnership     Trust

List all Principals Comprising Mortgagor Entity: provide name and title of each principal. Use extra sheets, if needed. If mortgagor is a:  
• corporation, list: (1) all officers; (2) all directors; and (3) each stockholder having a 10% or more interest.  
• partnership, list: (1) all general partners; and (2) limited partners having a 25% or more interest in the partnership.  
• trust, list: (1) all managers, directors or trustees and (2) each beneficiary having at least a 10% beneficial interest in the trust.

Name and Title

Robert Margolis, Managing Member

Managing Member

Name and Title

Name and Title

Name and Title

Name and Title

Name and Title

Name and Title

Name and Title

Name and Title

Name and Title

Name and Title

**Part H – Owner Certification**

To the best of my knowledge, all the information stated herein, as well as any information provided in the accompaniment herewith, is true and accurate.

**Warning:** HUD will prosecute false claims and statements. Conviction may result in criminal and/or civil penalties. (18 U.S.C. 1001, 1010, 1012; 31 U.S.C. 3729, 3802)

Name and Title

Robert Margolis  
Managing Member

Authorized Official's Signature

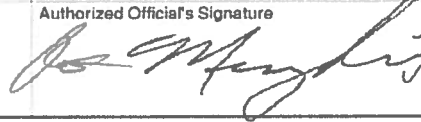

Date (mm/dd/yyyy)  
09/30/2019

**Part I – HUD/Lender Approval**

Addendum Number

Branch Chief/Lender Official Signature

HAP Contract Number

Exhibit Number

Loan Servicer Signature

Date (mm/dd/yyyy)

Blanca Romero

10/8/2019

Director, Housing Management Division Signature



Date (mm/dd/yyyy)

10/8/2019

Public reporting burden for this collection of information is estimated to average 20 minutes per response, including the time for reviewing instructions, searching existing data sources, gathering and maintaining the data needed, and completing and reviewing the collection of information. This agency may not collect this information, and you are not required to complete this form, unless it displays a currently valid OMB control number.

This collection of information is authorized under Section 207 of the National Housing Act. The information is necessary for the Department to ensure that project owners are not overcharging their tenants and to ensure that the rent levels approved by the Department are not exceeded. The Department uses this information to enforce rent regulations which otherwise would be difficult because there would be no clear record of the rents and charges that the Department had approved. In addition, the Department needs to periodically collect information regarding project principals, so unauthorized participation by previously excluded or otherwise undesirable owners can be detected. This information is required to obtain benefits. HUD may disclose certain information to Federal, State, and local agencies when relevant to civil, criminal, or regulatory investigations and prosecutions. It will not be otherwise disclosed or released outside of HUD, except as required and permitted by law.

### Instructions

All project owners must submit the form HUD-92458 when requesting an adjustment to project rents. HUD establishes and approves rental charges and utility allowances on the Form. The owner is responsible for notifying tenants of the approved rents.

**General.** For projects with fully-insured or HUD-held mortgages, the owner/agent submits this Form to the HUD Field Office. For projects with coinsured mortgages, the owner/agent submits this Form to the lender.

**Part A.** If the monthly rent potential you are proposing is less than or equal to the Maximum Allowable Monthly Rent Potential approved by HUD/lender on your original Rent Formula or on your most recent Rent Computation Worksheet, complete all of Part A according to the instructions below. If the monthly rent potential you are requesting exceeds the Maximum Allowable Monthly Rent Potential approved by HUD/lender on your original Rent Formula or on your most recent Rent Computation Worksheet, complete only Columns 1 and 2 according to the instructions below. Show your proposed rents and monthly rent potential in the cover letter transmitting your rent increase request.

**Column 1.** Show each type of unit for which rents will vary. Show the number of bedrooms and bathrooms and other features that cause rents to vary (e.g., 2 BDM, 1 B, DA, KETTE, vs 2 BDM, 2B, DR, K). Use the following symbols:

BDM	- Bedroom	LR	- Living Room
B	- Bath	DR	- Dining Room
K	- Kitchen	DA	- Dining Alcove
KETTE	- Kitchenette		

**Column 2.** Show the number of units for each unit type. Include non-revenue producing units.

**Column 3.** For unsubsidized projects, show the rent you intend to charge for each unit type. For subsidized projects, show the contract rent (as defined in HUD Handbook 4350.3) for each unit type.

**Column 4.** For each line, multiply the contract rent in Column 3 by the number of units in Column 4. Add monthly contract rent potentials for each unit size to compute the total monthly contract rent potential. Multiply the monthly total by 12 to compute the annual contract rent potential.

**Columns 5 and 6.** Complete the Columns only if the project has a subsidy contract with HUD and some utilities are not included in the rent. In Column 5, show the utility allowance for each unit type. Compute the gross rent for each unit type by adding the contract rent in Column 3 and the utility allowance in Column 5. Show this amount in Column 6.

**Columns 7 and 8.** Complete these Columns only if the project is receiving Section 236 Interest Reduction Payments. In Column 7, show the market rent for each unit type. In Column 8, for each line multiply the market rent in Column 7 by the number of units in Column 2. Add the monthly market rent potentials for each unit size to compute the total monthly market rent potential. Multiply the monthly total by 12 to compute the annual market rent potential.

**Parts B, C, D and E.** Complete these Parts according to the instructions on the Rent Schedule.

**Part F.** Do not complete this Part. The HUD Field Office/lender will complete this Part.

**Parts G and H.** Complete these Parts according to the instructions on the Rent Schedule.

**Part I.** Do not complete this Part. The HUD Field Office/lender will complete this part.



**U.S. Department of Housing and Urban Development**  
Baltimore Multifamily HUB Office  
Baltimore Satellite Office  
Bank of America Building, Suite 500  
Baltimore, MD 21201

September 27, 2019

**NEW WESTSIDE VILLAGE I LIMITED  
PARTNERSHIP**  
1375 Piccard Drive #150  
Rockville, MD 20850

Subject: Automatic OCAF Rent Increase  
Westside Village  
VA36H027004  
Rent Comparability Study Expires: 02/08/2022

Dear Owner/ Mortgagor:

Westside Village is in a multi-year Housing Assistance Payments Contract and , as such, is eligible for an automatic OCAF rent increase to become effective 12/01/2019. The rent increase factor is 1.026. The debt service amount used in the calculation of new rents is \$0.00.

Should you elect this rent increase, the new rents for Westside Village will be as indicated on the attached Exhibit A. Complete, execute, and return three (3) forms HUD-92458 Rent Schedule Low Rent Housing to your HUD/PBCA within 10 days of receipt of this package.

Indicate below which rent increase option you are requesting be applied in the upcoming contract year. Complete the Project information section that follows and return this Notice and any attachments to your HUD/PBCA within 10 days of receipt of this package (check one).

- I elect to receive the attached automatic OCAF rent increase.
- I elect to receive the attached automatic OCAF rent increase and am submitting a Utility Analysis and recommendation for a change to the Utility Allowances. Supporting documentation is enclosed.

- I request a **zero** budget-based rent adjustment in lieu of the OCAF adjustment and understand that this will result in renewed funding at current rents. I further understand that the OCAF adjustment for this year may not be recouped retroactively in the future. If applicable, I am submitting a Utility Analysis and recommendation for a change to the Utility Allowances. My signature on this letter certifies that I have reviewed the project's income and expenses and they are at levels that will enable me to continue to provide decent, safe and sanitary housing.
- I request a Budget Based Rent Increase for the upcoming contract year. The required documentation for this rent increase is enclosed. If applicable, I am submitting a Utility Analysis and recommendation for a change to the Utility Allowances.
- Other: \_\_\_\_\_

I (We) hereby **certify** that the debt service amount of \$0.00 and the non-section 8 rent potential amount of \$0.00 are true, accurate and complete to the best of my (our) knowledge and belief.

Project Name: WESTSIDE VILLAGE

Owner Name: NEW WESTSIDE VILLAGE I LIMITED PARTNERSHIP

Owner Signature:  Date: 9/30/2019

Should you have any questions, please contact our office. It is very important that you send your response to the attention of Blanca.Romero@hud.gov.

Sincerely,

  
BLANCA M ROMERO  
Account Executive

OMB Control #2502-0587

Exp. (10/31/2012)

Public reporting burden for this collection of information is estimated to average 1 hour. This includes the time for collecting, reviewing, and reporting the data. The information is being collected for purposes of determining rent adjustments and will be used for estimating new rents. Response to this request for information is required in order to receive the benefits to be derived. This agency may not collect this information, and you are not required to complete this form unless it displays a currently valid OMB control number. No confidentiality is assured.

Privacy Act Notice: The United States Department of Housing and Urban Development, Federal Housing Administration, is authorized to solicit the information requested in the form by virtue of Title 12, United States Code, Section 1701 et seq., and regulations promulgated thereunder at Title 12, Code of Federal Regulations. While no assurance of confidentiality is pledged to respondents, HUD generally discloses this data only in response to a Freedom of Information Act request.

Attachment

form HUD-9627 (02/2009)

Amend Rents Auto OCAF Part B



**EXHIBIT A**

**IDENTIFICATION OF UNITS ("CONTRACT UNITS")  
BY SIZE AND APPLICABLE CONTRACT RENTS**

**Section 8 Contract Number: VA36H027004**

**FHA Project Number:**

**Effective Date of the Rent Increase: 12/01/2019**

<b>Number of Contract Units</b>	<b>Number of Bedrooms</b>	<b>Contract Rent</b>	<b>Utility Allowance</b>	<b>Gross Rent</b>
8	1	\$485.00	\$62.00	\$547.00
34	2	\$565.00	\$95.00	\$660.00
22	3	\$738.00	\$113.00	\$851.00
6	4	\$781.00	\$135.00	\$916.00

**Do not submit a Gross Rent Change through TRACS until the HUD-92458 Rent Schedule has been returned to you duly executed from your HUD/PBCA office.**

- Note:
- (1) This Exhibit will be amended by Contract Administrator notice to the Owner to specify adjusted contract rent amounts as determined by the Contract Administrator in accordance with the Renewal Contract.
  - (2) These rents are applicable with the Amend Rents Automatic OCAF for this effective Date.



NEW WESTSIDE VILLAGE I LIMITED PARTNERSHIP  
DBA WESTSIDE VILLAGE APARTMENTS  
FHA PROJECT NO.: VA36-HO27-004

FINANCIAL STATEMENTS  
(WITH SUPPLEMENTAL INFORMATION)  
AND INDEPENDENT ACCOUNTANT'S COMPILATION REPORT

DECEMBER 31, 2018 AND 2017



New Westside Village I Limited Partnership

TABLE OF CONTENTS

	PAGE
MORTGAGOR'S CERTIFICATION	2
MANAGING AGENT'S CERTIFICATION	3
INDEPENDENT ACCOUNTANT'S COMPILATION REPORT	4
FINANCIAL STATEMENTS	
BALANCE SHEETS	5
STATEMENTS OF OPERATIONS	7
STATEMENTS OF PARTNERS' EQUITY (DEFICIT)	8
STATEMENTS OF CASH FLOWS	9
NOTES TO FINANCIAL STATEMENTS	10
SUPPLEMENTAL INFORMATION	16

New Westside Village I Limited Partnership

December 31, 2018

MORTGAGOR'S CERTIFICATION

We hereby certify that we have examined the accompanying financial statements and supplemental data of New Westside Village I Limited Partnership, FHA Project No.: VA36-HO27-004 and, to the best of our knowledge and belief, the same are complete and accurate.

By: NEW WESTSIDE VILLAGE I LIMITED  
PARTNERSHIP

---

Bob Margolis Date  
Member, MARG Rural, LLC  
General Partner

New Westside Village I Limited Partnership

December 31, 2018

MANAGING AGENT'S CERTIFICATION

I hereby certify that I have examined the accompanying financial statements and supplemental data of New Westside Village I Limited Partnership and, to the best of my knowledge and belief, the same are complete and accurate.

MANAGING AGENT

TM Associates Management, Inc.  
1375 Piccard Dr., Suite 150  
Rockville, Maryland 20850

---

Amy Brown Date  
Chief Financial Officer

Managing Agent Taxpayer  
Identification Number:  
52-2173104



## INDEPENDENT ACCOUNTANT'S COMPILATION REPORT

To the Partners of  
New Westside Village I Limited Partnership

Management is responsible for the accompanying financial statements of New Westside Village I Limited Partnership (a Virginia limited partnership), FHA Project No.: VA36-HO27-004, which comprise the balance sheets as of December 31, 2018 and 2017, and the related statements of operations, changes in partners' equity and cash flows for the years then ended, and the related notes to the financial statements in accordance with accounting principles generally accepted in the United States of America. We have performed the compilation engagement in accordance with Statements on Standards for Accounting and Review Services promulgated by the Accounting and Review Services Committee of the AICPA. We did not audit or review the financial statements nor were we required to perform any procedures to verify the accuracy or completeness of the information provided by management. Accordingly, we do not express an opinion, a conclusion, nor provide any form of assurance on these financial statements.

### **Supplemental Information**

The supplemental information is presented for purposes of additional analysis and is not a required part of the basic financial statements. This information is the representation of management. The information was subject to our compilation engagement, however, we have not audited or reviewed the supplemental information and, accordingly, do not express an opinion, a conclusion, nor provide any form of assurance on such supplemental information.

*Tidwell Group, LLC*

Columbus, Ohio  
March 18, 2019

S

Supportive Housing  
Certification



**N/A**

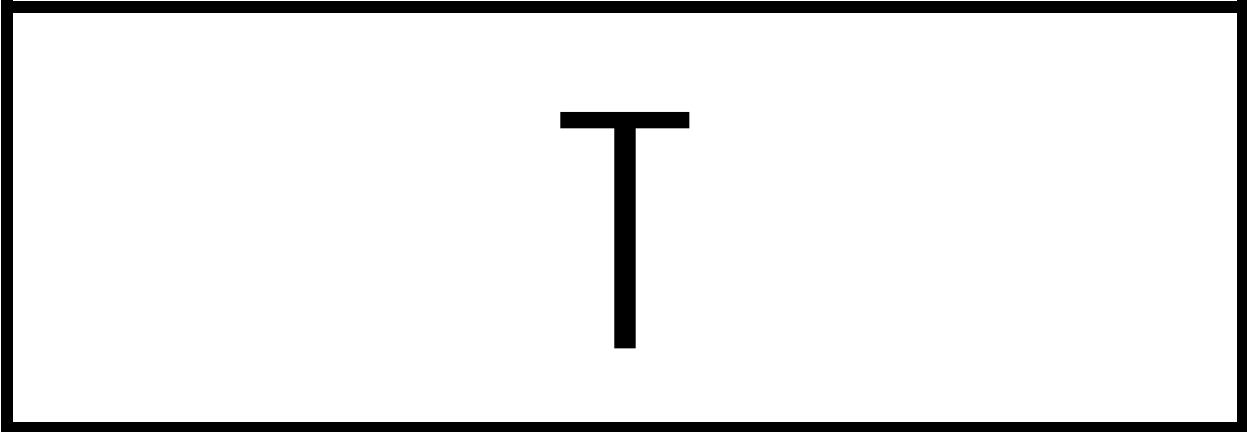

T

Funding Documentation



*777 West Putnam Avenue  
Greenwich, CT 06830  
(p) 203.869.0900  
(f) 203.869.1034*

March 10, 2020

Westside Village Renewal, LLC  
c/o Mr. Todd Travis  
Huntington Housing, Inc.  
11810 Grand Park Avenue  
Suite 600  
North Bethesda, MD 20852

Re: Westside Village Apartments, South Boston, VA

Dear Mr. Travis:

The Richman Group Affordable Housing Corporation ("TRG") is the sponsor of investment partnerships which provide equity capital for multi-family apartment complexes that are eligible for low-income housing tax credits ("Low-Income Housing Tax Credits") pursuant to Section 42 of the Internal Revenue Code of 1986 (the "Tax Code") by investing in limited partnerships that own such apartment complexes.

You have advised us that Westside Village Manager, LLC (the "Managing Member"), a single-purpose, for-profit, wholly-owned subsidiary of Huntington Housing, Inc. has formed Westside Village Renewal LLC, a Virginia limited liability company (the "Company"), which intends to acquire and rehabilitate a 70-unit apartment complex located in South Boston, VA (the "Apartment Complex").

TRG is pleased to provide you with this letter of intent for the acquisition by an affiliated limited partnership, which will be sponsored by TRG ("Investor"), of a 99.99% membership interest in the Company, subject to the terms and conditions hereof. Upon the execution of this letter, TRG will commence its due diligence review and will hold an initial investment committee meeting. Upon approval of the initial investment committee, TRG may continue its due diligence and will seek an investor to acquire the membership interest. Receipt of initial investment committee approval is not, and should not be construed as, an indication that the transaction will receive final investment committee approval. Only upon (i) the receipt of final investment committee approval, (ii) negotiation and execution of documentation acceptable to both parties and (iii) receipt of opinions of counsel (including corporate, tax and real estate) acceptable to the Investor, will the parties execute an amended and restated operating agreement of the Company in the Investor's standard form (the "Operating Agreement"), admitting the Investor to the Company. National Foundation for Affordable Housing Solutions ("NFAHS") or another entity with sufficient net worth acceptable to TRG (the "Guarantor") will guarantee the Managing Member's obligations to the Investor.

1. Financing: Financing of the Apartment Complex will be subject to Investor approval. You have informed us that the Apartment Complex will receive financing as follows: (i) a first mortgage loan from a conventional lender in the anticipated amount of \$2,314,242 with an all-in interest rate not to exceed 4.35%



- (i) Achievement of 75% completion of construction of the Apartment Complex, as certified by the Contractor and the Architect;
- (ii) Receipt of an estoppel letter from each lender to the Company; and
- (iii) October 1, 2021.

**Installment No. 5: (10.368%)**

**\$756,822**

Paid upon the latest of the following:

- (i) Completion of construction of the Apartment Complex, as certified by the Contractor and the Architect, receipt of certificates of occupancy for all units in the Apartment Complex if required by the applicable governmental jurisdiction, and receipt of all other governmental permits required in connection with the completion, use and occupancy of the Apartment Complex or a written certification from the Managing Member that no such additional governmental permits are required;
- (ii) Receipt of a payoff letter from the Contractor which states that upon receipt of Installment No. 5 the construction contract will be paid in full by such Installment No. 4 or the Contractor will defer any amounts owed to it until the payment of Installment No. 5;
- (iii) Receipt of an estoppel letter from each lender to the Company;
- (iv) Receipt of certificates of insurance complying with the requirements described herein; and
- (v) January 1, 2022.

**Installment No. 6: (8.540%)**

**\$623,420**

Paid upon the latest of the following:

- (i) Achievement of 100% qualified occupancy by tenants who qualify under Section 42 and who are paying rents (net of concessions) at amounts which are at least equal to those set forth on Attachment A;
- (ii) Achievement of "Breakeven Operations" (as defined below);
- (iii) Achievement of final endorsement/closing of the 1<sup>st</sup> mortgage loan and final closing of all other permanent financing to the Company;
- (iv) Funding of the "Operating Reserve" as described in Paragraph 7 below;
- (v) Receipt of evidence satisfactory to the Investor that the monthly mandatory debt service payments on the 1<sup>st</sup> mortgage loan have not increased from the approved underwritten levels;
- (vi) Receipt of Form 8609 for each building in the Apartment Complex;
- (vii) Receipt of final Low-Income Housing Tax Credit certification from the accountant for the Company including Form 8609, and review and approval of such by Cohn Reznick on behalf of the Investor with the cost of such Cohn Reznick review paid by Investor;

- (viii) Receipt of an estoppel letter from each lender to the Company; and
- (ix) and July 1, 2020.

Total Equity to Company (excluding amounts payable under Section 15 below): **\$7,299,684**

Installment No. 6 will only be released upon the achievement of Breakeven Operations. "Breakeven Operations" is generally defined as the following: (i) the date upon which income from the normal operation of the Apartment Complex, received on a cash basis, for each of the consecutive calendar months in the applicable "Test Period" (as defined below) after permanent mortgage loan closing, less all mandatory debt service payments for each month (or, if Final Closing has not yet occurred, the breakeven analysis shall include the mandatory monthly debt service monthly payments that would be due on the permanent loans if Final Closing had been achieved), equals or exceeds 1.15 multiplied by: (i) the greater of (a) underwritten or (b) actual accrued operational costs for each of such three (3) consecutive months ("Test Period 1"), or (ii) all actual accrued operational costs, adjusted for applicable seasonal cost variations, for each of six (6) consecutive months ("Test Period 2") or, (iii) all operational costs for a 12 month period (as reported under GAAP) ("Test Period 3") as evidenced by an audited financial statement prepared by the accountant for the Company. In addition, Breakeven Operations shall not have occurred unless, at the end of such applicable Test Period, the Company shall have (i) sufficiently funded segregated reserves to pay one (1) year's property insurance premiums (minus any prepaid premiums on the existing insurance policy) and the next full installment of real estate taxes payable (minus any prepaid taxes with respect to such installment) and (ii) liquid assets not committed to the payment of any other expense or reserve fund in an amount sufficient to pay (a) one (1) month's mandatory debt service payment plus (b) any other accrued unpaid expenses.

3. **Adjuster Clause:** The Capital Contribution amount stated above is based upon your projection of an annual amount of Low-Income Housing Tax Credits of \$811,157 ("LIHTC") which in turn is based upon certain of the assumptions and projections stated in Schedule A herein. The actual amount of Low-Income Housing Tax Credits may in fact change after the determination of eligible and qualified basis. Accordingly, the Capital Contribution may be adjusted when (i) final projections of the amount of Low-Income Housing Tax Credits are completed and/or (ii) upon or after actual completion of the Apartment Complex. To the extent such final projected amount of Low-Income Housing Tax Credits varies from the LIHTC, the Capital Contribution will be adjusted as set forth in the following paragraph and as will be more particularly set forth in the Operating Agreement.

If the final amount of Low-Income Housing Tax Credits ("Final LIHTC") is greater or less than the LIHTC then the Capital Contribution shall be adjusted so that the ratio of the Capital Contribution attributable to the Low-Income Housing Tax Credits divided by the Final LIHTC allocable to Investor is equal to 90.00% ("LIHTC Ratio"). However, in the case of an increase, such increase in Capital Contribution will take place only if the Investor has funds available which are not committed otherwise. If the Investor does not have funds available to pay for the higher amount of Low-Income Housing Tax Credits, then the Investor's interest in the Company will be adjusted downward accordingly, but in no event below a 90% interest. If the adjustment would result in an adjustment below 90% then TRG may in its discretion endeavor to cause an affiliated investment partnership to purchase an interest in the Company, but shall have no liability if it is unable to do so.

4. **Timing Differences:** In the event that the actual Final Reported Credit for 2021 is more or less than 83.33% of the LIHTC or for 2022 is less than 100.00% of the LIHTC (or LIHTC as adjusted pursuant to paragraph 2 above) then the Capital Contribution of the Investor to the Company shall be increased or decreased as appropriate (a "Timing Change"), by an amount sufficient to maintain an Internal Rate of Return to the Investor equal to a rate agreed upon at Closing; such adjustment to be based upon the methodology set forth on Attachment A assuming for this purpose that (i) the amount and timing of projected losses and deductions and (ii) the timing of the Capital Contributions will be fixed at the amounts shown in the projections attached to the Operating Agreement. With respect to the calculation of the losses in the parenthetical above, the Investor shall, for the years in which it has sufficient tax information, make the calculation for those years using the lesser of the actual losses or the projected losses. In the years in which there is not sufficient tax information to calculate actual losses, the projected losses shall be used. In the

event that the Timing Change exceeds the then unpaid Capital Contribution of the Investor, the Managing Member shall pay to the Investor, immediately upon demand, the amount by which the Timing Change exceeds such then unpaid Capital Contributions. In the event that an upward Timing Change and/or the LIHTC Ratio adjuster described in Paragraph 3 results in an increase in the Capital Contribution, such increases combined will be capped at 5% of the original Capital Contribution.

5. Cash Flow Distributions: Cash flow of the Company after expenses and debt service will be distributed, to the extent available, according to the following priority:

- First: to pay any credit adjuster due;
- Second: a priority distribution to the Investor in the amount of \$3,000 annually;
- Third: to pay any deferred development fee to the developer;
- Fourth: to repay any operating deficit loans made by the Managing Member;
- Fifth: remaining amounts split 10% to the Investor and 90% to the Managing Member.

6. Sale or Refinance: Upon the sale of the Apartment Complex or a refinancing of the permanent mortgage loan, proceeds will generally be allocated in accordance with the following priority:

- First: Expenses of the sale and refinancing and satisfaction of underlying financing plus any other third-party obligations and debts;
- Second: Return of the outstanding balance of any operating deficit loans previously made by the Managing Member (See Guarantees); and
- Third: Balance of proceeds split 10% to the Investor, 90% to the Managing Member.

The percentage splits between the Investor and Managing Member described in Paragraphs 5 and 6 assume that the transaction will be structured such that anti-churning rules for affiliated entities will not disallow the percentage splits shown.

7. Guarantees: The Managing Member and the Guarantor shall jointly and severally guarantee the obligations of the Managing Member under the Operating Agreement, including, without limitation, the following:

(A) Against recapture of the Low-Income Housing Tax Credits for 15 years except for recapture caused by (i) subsequent changes in the Tax Code or (ii) transfers of the Investor's interest in the Company.

(B) The payment in full of all costs and expenses of the acquisition and construction of the Apartment Complex in excess of the proceeds of all the construction period sources of funds and any operating deficits prior to the achievement of Breakeven Operations.

(C) To fund operating deficits for a five (5) year period (the "Operating Deficit Period") from the later of Breakeven Operations or funding of the permanent mortgage loan up to a maximum amount of \$237,643 (the "Operating Deficit Guaranty"). The Operating Deficit Period shall be deemed extended until (x) the Managing Member has provided the Investor with evidence that the Company has sufficient cash reserves to pay any accrued expenses as of the expiration of the Operating Deficit Period and (y) the Apartment Complex has achieved the "DSC Requirement" as hereinafter defined. The "DSC Requirement" means that the Apartment Complex has demonstrated a debt service coverage ratio of 1.10:1 for years four and five of the Operating Deficit Period. If the Apartment Complex has not demonstrated a 1.10:1 debt service coverage for such years the Operating Deficit Period will be extended until the Apartment Complex demonstrated a 1.10:1 debt service coverage for two consecutive years. For purposes of the Operating

Deficit Guaranty, the term "Operating Deficits" shall include amounts withdrawn from the reserve for replacements for non-capital costs during such five (5) year period. A further assurance will be an agreement by the managing agent for the Apartment Complex, typically the Managing Member or an affiliate, (the "Managing Agent") to (i) defer and accrue its management fee, if necessary, to prevent a default under the permanent mortgage loan and (ii) defer its fee to the extent necessary to avoid an Operating Deficit. If the Managing Agent elects not to defer its fee pursuant to subparagraph (ii) above, it must send a notice to the Managing Member and the Investor offering to resign. If no such notice is sent, the Managing Agent will be deemed to have ratified its agreement to defer its fee. If a notice is sent refusing to defer its fee, such refusal shall be grounds for removal of the Managing Agent.

An operating/debt service reserve in the cumulative amount of \$237,643 (collectively, the "Operating Reserve") will be funded at or prior to payment of Installment No. 6. Subject to Investor approval, any operating deficit reserves and debt service reserves required by the lenders or the Agency may be applied toward the obligation to fund the Operating Reserve described in the previous sentence, however, such other reserves must remain as a Company reserve account for the full term that the Operating Reserve is required with terms acceptable to the Investor. Withdrawals made from the Operating Reserve will be subject to approval by the Investor. Withdrawals made from the Operating Reserve after achievement of Breakeven Operations will count toward fulfillment of the Operating Deficit Guaranty described in the preceding paragraph. However, the balance of the Operating Reserve may not be drawn below one-half of the initial funded amount of the Operating Reserve during the Operating Deficit Period.

Subject to satisfactory underwriting, after the end of the Operating Deficit Period, funds remaining in the Operating Reserve in excess of \$118,822 may be released to cash flow of the Company if "Release Test 1" (as defined below) is met as follows: "Release Test 1" shall be met if all of the following conditions are achieved: (i) no default exists under the Operating Agreement, and (ii) the project-based Section 8 rental assistance on the Apartment Complex has not been terminated or reduced.

Additionally, subject to satisfactory underwriting, the remaining balance of the Operating Reserve may be released to cash flow of the Company if "Release Test 2" (as defined below) is met as follows: "Release Test 2" shall be met if all of the following conditions are achieved: (i) no default exists under the Operating Agreement, (ii) the project-based Section 8 rental assistance on the Apartment Complex has not been terminated or reduced, and (iii) the Apartment Complex has maintained a debt service coverage of at least 1.20 on all mandatory debt service for a 12-month period commencing not earlier than the year after Release Test 1 is met, as evidenced by an audited financial statement. However, upon release of this remaining \$118,821 from the Operating Reserve, the Managing Member shall then guarantee the funding of subsequent operating deficits during the remainder of the 15-year compliance period, up to a cumulative maximum amount of \$118,821, exclusive of any operating deficits funded by the Managing Member prior to the time of the final release of the Operating Reserve described above.

(D) Repurchase of the Investor's interest in the Company by payment to the Investor of the full amount of the gross Capital Contribution paid to such date, if the Managing Member fails to (i) place the Apartment Complex in service by December 31, 2022, (ii) complete Final Closing by December 1, 2023, (iii) achieve at least 70% of the aggregate projected LIHTC as set forth herein, or (iv) achieve Breakeven Operations within 24 months of Substantial Completion (to be defined in the Operating Agreement) of the Apartment Complex.

8. Representations and Warranties: The Managing Member shall provide the representations and warranties to the Investor more particularly set forth in the Operating Agreement and currently has no basis to believe that such representations and warranties cannot be given at Closing. The Managing Member shall be obligated to recertify to the continued truth and accuracy of such representations and warranties at the time of each installment of capital contributions.

9. Duties and Obligations: The Managing Member shall be obligated to assume the duties and obligations as are set forth in the Operating Agreement.



10. Legal Opinions: The Managing Member shall cause the attorneys for the Company to provide the legal opinions more particularly set forth in the Operating Agreement.
11. Sale or Conversion: Beginning 15 years from the date of the closing of the permanent mortgage loan, if the Investor requests the Managing Member to sell the Apartment Complex, the Managing Member will consent, provided such sale meets the approval of the lender and applicable tax credit agency. In the event the Managing Member does not consent to a sale at that time, the Managing Member will be granted an option to purchase the Apartment Complex at fair market value (as restricted by the uses mandated by the lender and the Tax Credit Agency). In the event that the Managing Member chooses not to exercise this purchase option, the Investor shall reserve the right to: (i) sell its interest in the Company to the Managing Member for \$1 or (ii) transfer its membership interest in the Company to an affiliated entity, provided however, a qualified non-profit Managing Member or its qualified non-profit designee will be granted a right of first refusal to purchase the Apartment Complex at the "Minimum Purchase Price" as defined in Section 42(i)7 of the Internal Revenue Code of 1986 and in accordance with requirements mandated by the lender and the Tax Credit Agency.
12. Accountants and Financial Reporting: The "Accountants" for the Company shall be Cohn Reznick or such other firm acceptable to the Investor. Financial information will be required to be submitted to the Investor by the 30th day after the end of each quarter, for the first three calendar quarters of each year. Such financial information may be unaudited and may be prepared by the Managing Agent. Annual audited financial statements and tax information in draft form will be required to be submitted to the Investor by the Managing Member by February 15 of each year with final audited financial statements and tax information submitted to the Investor by the Managing Member by February 28 of each year. In the event that such final information is not submitted to the Investor by March 15 of each year, then the Managing Member shall be obligated to pay to the Investor an amount equal to \$350 for each day that such tax or other information is past due, which amount may be waived by the Investor at its sole discretion for reasonable cause; provided however, that if such late charge is not paid by the Managing Member within ten (10) days of demand therefor from the Managing Member, then the Management Agent shall be obligated to pay such late charge to the Investor. Any such late charge shall be returned by the Investor if at the end of three (3) years after the date of payment thereof, the following conditions are met: (1) such late charge was the first one incurred pursuant to this Section 13.04, (2) such late charge was in an amount of \$2,500 or less, (3) no other late charge shall have been assessed during such three-year period, and (4) such late charge was paid promptly on demand.
13. Removal Rights: The Investor shall have the right to remove the Managing Member for cause as will be set forth in the Operating Agreement. No removal right without cause shall exist.
14. Indemnity: In the Operating Agreement the Managing Member shall indemnify Investor and its officers, directors and affiliates for any untrue statement of a material fact or omission to state a material fact necessary to make any such statements, in light of the circumstances under which they were made, not misleading, by the Managing Member or their agents set forth in any document delivered by the Managing Member or their agents in connection with the acquisition of the Apartment Complex, the investment by the Investor in the Company and the execution of the Operating Agreement.
15. Reserve Requirements: The Company will be required to make an annual minimum deposit to a reserve for replacements in an amount equal to the greater of (i) \$300 per unit per year increasing by 3% annually, or (ii) the amount utilized in the underwriting of the mortgage loans by the lenders. The Investor may require that additional reserves be funded to cover potential cash deficiencies. The Operating Deficit Guaranty shall be increased by amounts withdrawn from the reserve for replacements for non-capital costs during the Operating Deficit Period.
16. Due Diligence: TRG and the Investor will have the opportunity to perform, and you and your professionals will assist us in, the customary due diligence necessary in the acquisition of the Apartment Complex and of the investment by Investor in the Company. As a condition of closing, the Company shall provide the Investor information reasonably requested by the Investor, including without limitation, (i) market rental information, proving that the projected rents will be achieved and the rent up will occur within a

reasonable absorption period, (ii) engineering report by an engineer acceptable to the Investor and (iii) a Phase 1 environmental report. The Company shall bear the costs of Investor's, market study, engineering review and Investor's legal counsel, subject to a maximum of \$--0--. A sample (but not exhaustive) list of due diligence documents shall be forwarded upon receipt by the Investor of a fully executed copy of this letter. Additionally, approval of this transaction is subject to Investor satisfaction and completion of due diligence (including site visit, review, and investment committee approval), and receipt by the Company of a Low-Income Housing Tax Credits reservation or allocation approval from the appropriate state or local agency.

17. Title Insurance: The Managing Member shall provide, at Company expense, title insurance in favor of the Company in an amount not less than the sum of (i) all mortgage loans, and (ii) the amount of the Capital Contribution with only those exceptions as may be approved by Investor.

18. Execution of Operating Agreement: As a condition to the Closing, the Managing Member will execute the Operating Agreement and any related documentation necessary to complete the transaction and the Guarantor must execute the Guaranty.

19. Hazard and Liability Insurance: As a condition to receipt of Installment No. 1 of Capital Contributions, the Company shall deliver evidence of hazard insurance from carriers acceptable to the Investor, in an amount equal to the replacement cost of the apartment improvements. The hazard insurance must include endorsements for inflation adjustment and code upgrade coverage. Liability insurance shall be in the amount of not less than \$5,000,000.

20. Escrows: To the extent not required by any mortgage lender, the Company shall maintain funds in a segregated escrow account, in an amount sufficient to pay all real estate taxes and insurance premiums when due.

21. Payment and Performance Bond or Letter of Credit: The Contractor shall provide one of the following (i) payment and performance bonds in form and substance satisfactory to Investor, in the full amount of the general contract naming the Company as obligee issued by a bonding company acceptable to Investor, or (ii) a letter of credit in the amount of not less than 15% of the general contract issued by a bank acceptable to Investor.

22. Brokers. Any and all fees due to any broker involved in this transaction will be the responsibility of the Managing Member. By executing this letter of intent, you represent and warrant that no broker has been involved in the negotiations among the Managing Member, its principals and TRG. You further acknowledge and agree that neither TRG nor the Investor shall be responsible for the payment of any brokerage fees in connection with the Investor's investment in the Project unless otherwise specifically agreed to in writing by TRG.

If the above is acceptable to the Managing Member, please execute a copy of this letter and return it to the Investor. In the event that Investor is not in receipt of an executed copy of this letter within thirty (30) days, this letter shall be considered withdrawn and shall be of no further force or effect.

Upon the Investor's receipt of a fully executed copy of this letter, the Investor will commence the necessary action to deliver to you a copy of the proposed Operating Agreement and you shall be bound by all of the terms and provisions hereof. If prior to the expiration of the due diligence period Investor agrees to proceed with the transaction, but notwithstanding such agreement, the Managing Member (i) fails to negotiate the Operating Agreement or other closing documents in good faith and/or (ii) offers the membership interest contemplated hereby to a third party, then the Managing Member shall be obligated to reimburse Investor and/or TRG for all fees, costs and expenses incurred by Investor and/or TRG in connection with this transaction, including without limitation, all legal fees and disbursements, engineering and other professional fees, site inspection fees, market study fees, appraisal fees, background investigation costs, and other due diligence costs and expenses.

The Closing of the acquisition of the membership interest is subject to the availability of funds and the ability of TRG to identify an Investor. This letter shall be governed by and construed in accordance with

the internal laws of the State of Connecticut. This agreement shall not create any liability on the part of TRG or the Investor. All rights and obligation of the Investor shall be set forth in the Operating Agreement and shall not be binding on the Investor until the Investor delivers a fully executed copy of the Operating Agreement to the Managing Member.

Notwithstanding anything to the contrary contained herein, the provisions of this letter represent the entire understandings of TRG, the Investor, the Managing Member and/or the Company with respect to the matter hereof, and all prior understandings, agreements and representations with respect thereto whether written or oral are superseded hereby and merged herein. None of the provisions of this letter may be waived or modified unless such waiver or modification is in writing and signed by the parties hereto and approved by TRG's counsel. No oral agreements shall ever be binding on TRG and/or the Investor.

***Signatures on following page***

Sincerely,

The Richman Group Affordable Housing Corporation

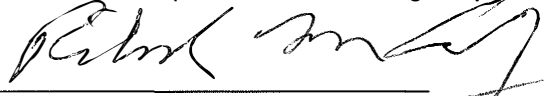
By:   
Name: Richard McCauley  
Title: Executive Vice President



## ORIX Real Estate Capital, LLC

10 West Broad Street, 8<sup>th</sup> Floor  
Columbus, OH 43215  
Tel: 614-857-1400 800-837-5100

March 11, 2020

Todd Travis  
National Foundation for Affordable Housing Solutions, Inc.  
11810 Grand Park Avenue, Suite 600  
North Bethesda, MD 20852

Re: Permanent Loan Financing for Westside Village Apartments (the “Project”), an existing 70-unit rental subsidized multifamily housing project located in South Boston, VA.

Dear Mr. Travis:

ORIX Real Estate Capital, LLC (“OREC”) is pleased to provide you with this conditional commitment letter to provide permanent financing through Fannie Mae on the above-referenced project.

The proposed terms shown below are based off of OREC’s review and underwriting of representations and information provided by you with regard to estimates of project costs, project income and expense figures, the limited market area data currently available to us, and the interest rate environment prevailing as of this date:

### Permanent Loan Financing

Lender:	ORIX Real Estate Capital, LLC
Borrower:	Single Asset Entity
Loan Program	Immediate Funding Fannie Mae Permanent Mortgage. Loan proceeds will be available to be used during the construction period.
Loan Amount:	\$2,314,242 (estimated)
Loan Term:	18 years
Loan Amortization:	35 years
Interest Rate:	4.35%

Rates are subject to daily fluctuations. The Interest Rates shall be fixed and locked prior to the closing of the mortgage.

Debt Service Coverage: 1.15x Minimum Allowable

Loan to Value: 90% Maximum Allowable.

Financing Fee: \$23,142

Security: A first mortgage lien on the property and the Project; a first assignment of rents and leases on the property or the Project; a senior security interest in Borrower’s furnishings, fixtures, and equipment and Borrower’s other tangible and intangible personal property acquired from, used in connection with or arising from the development, use or operating of the property or the Project; an assignment to OREC of any

distribution rights of the Borrower and the general partner(s) of their respective general partnership interests in the property and the Project

Prepayment: Yield maintenance of 15 years, 1% thereafter, open to prepayment without penalty during the last 3 months of the term. Alternative structures available.

Standard Conditions:

The Borrower shall pay all costs incident to the processing and closing of the permanent financing including (without limitation) title insurance premiums; recording and settlement costs; costs of survey; fees and expenses of environmental, engineering, architectural, accounting, legal, and other professionals providing services to the Borrower; hazard insurance premiums, and payment of any amounts due to deliver interest rate. The Borrower shall pay such costs regardless of whether or not the permanent financing is closed and funded.

Prior to a loan closing, Borrower and/or Guarantors will be required to comply with and meet OREC's standard pre-closing conditions. Said pre-closing conditions would be contained in a final OREC Commitment letter issued to Borrower at a future date, and would contain, but not be limited to, OREC's review and acceptance of items including the final underwriting, conditions of Borrower, and any other conditions which OREC or its legal counsel shall require.

You understand that the loan amounts and the other terms are only estimates based upon our preliminary analysis of the Project and the borrower, that such loan amounts may increase or decrease, and that such terms may change, depending upon the final underwriting of the property.

The terms and conditions of this letter will expire on March 11, 2021. We appreciate the opportunity to submit our proposal for the permanent financing of your rental subsidized development and look forward to working with you on this transaction.

Very truly yours,

ORIX Real Estate Capital, LLC



Tracy W. Peters  
Senior Managing Director

U

Documentation to  
Request Exception to  
Restriction-Pools with  
Little/No Increase in Rent  
Burdened Population



**N/A**

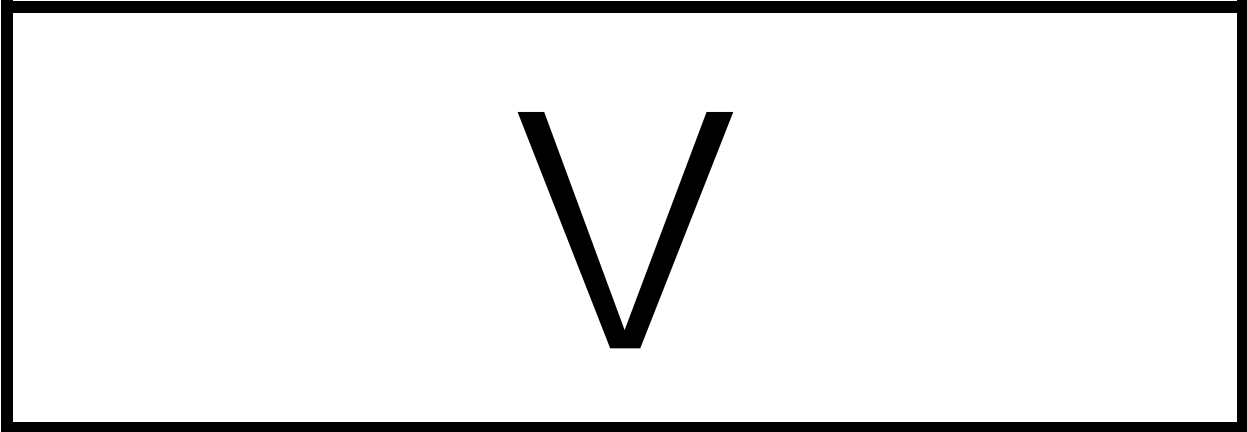

V

Nonprofit or LHA Purchase  
Option or Right of First  
Refusal

PURCHASE OPTION AND  
RIGHT OF FIRST REFUSAL AGREEMENT

This PURCHASE OPTION & RIGHT OF FIRST REFUSAL AGREEMENT (this "**Agreement**") is made as of February 24th, 2020, by and among WESTSIDE VILLAGE RENEWAL LLC, a Virginia limited liability company (the "**Company**"), HUNTINGTON HOUSING, INC. a Maryland nonstock corporation (the "**Grantee**"), and WESTSIDE VILLAGE MANAGER LLC, a Virginia limited liability company (the "**Managing Member**").

**WHEREAS**, the Managing Member, concurrently with the execution and delivery of this Agreement, is entering into that certain Operating Agreement dated as of the date hereof (the "**Operating Agreement**") establishing the Company; and

**WHEREAS**, Grantee will be instrumental in the development of that certain low-income housing project located in the City of South Boston, Virginia (the "**Apartment Complex**"), as described in the Operating Agreement, and will provide services to the Company in connection with the operation of the Company for the further development and operation of the Apartment Complex; and

**WHEREAS**, the Apartment Complex is or will be subject to a governmental agency regulatory agreement (the "**Regulatory Agreement**") restricting its use to low-income housing (such use restrictions under the Regulatory Agreement being referred to collectively herein as the "**Use Restrictions**"); and

**WHEREAS**, the Managing Member desires to provide for the continuation of the Apartment Complex as low-income housing upon termination of the Company by Grantee purchasing the Apartment Complex at the applicable price determined under this Agreement and operating the Apartment Complex in accordance with the Use Restrictions; and

**WHEREAS**, as a condition precedent to the formation or continuation of the Company pursuant to the Operating Agreement, the Managing Member has negotiated and required that the Company shall execute and deliver this Agreement in order to provide for such low-income housing;

**NOW, THEREFORE**, in consideration of the execution and delivery of the Operating Agreement and the payment by Grantee to the Company of Ten Dollars (\$10.00) and other good and valuable consideration, the receipt and sufficiency of which is hereby acknowledged, the parties hereby agree as follows:

1. Grant of Option. The Company hereby grants to Grantee an option (the "**Option**") to purchase the real estate, fixtures, and personal property comprising the Apartment Complex or associated with the physical operation thereof, located at the Apartment Complex and owned by the Company at the time of purchase, for a period of twelve (12) months (the "**Option Period**") following the close of the fifteen (15) year compliance period for the low-income housing tax credit for the Apartment Complex (the "**Compliance Period**") as determined under Section 42(i)(1) of the Internal Revenue Code of 1986, as amended (the "**Code**"), on the terms and conditions set forth in this Agreement and subject to the conditions precedent to the exercise of

the Option specified herein. The Apartment Complex real estate is legally described in Exhibit A attached hereto and made a part hereof.

2. Grant of Refusal Right. In the event that the Company receives a bona fide offer to purchase the Apartment Complex after the close of the Compliance Period (other than under the circumstances described in Paragraph 1), which offer the Company intends to accept, Grantee shall have a right of first refusal to purchase the Apartment Complex (the “**Refusal Right**”) for a period of twelve (12) months (the “**Refusal Right Period**”) following the close of the Compliance Period, on the terms and conditions set forth in this Agreement and subject to the conditions precedent to exercise of the Refusal Right specified herein. In addition to all other applicable conditions set forth in this Agreement, (a) the foregoing grant of the Refusal Right shall be effective only if Grantee is a qualified nonprofit organization, as defined in Section 42(h)(5)(c) of the Code currently and remains such at all times hereafter until the earlier of (i) the date that the Refusal Right has been exercised and the resulting purchase and sale has been closed or (ii) the date that the Refusal Right has been assigned to a Permitted Assignee described in Paragraph 10 hereof, and (b) any assignment of the Refusal Right permitted under this Agreement and the Refusal Right so assigned shall be effective only if the assignee is at the time of the assignment and remains at all times thereafter, until the Refusal Right has been exercised and the resulting purchase and sale has been closed, a Permitted Assignee described in Paragraph 10 hereof meeting the requirements of Section 42(i)(7)(a) of the Code. Prior to accepting any bona fide offer to purchase the Apartment Complex, the Company shall notify Grantee, the Managing Member and all other Members of such offer and deliver to each of them a copy thereof. The Company shall not accept any such offer unless and until the Refusal Right has expired without exercise by Grantee under Paragraph 6 hereof.

3. Purchase Price Under Option. The purchase price for the Apartment Complex pursuant to the Option (the “**Option Price**”) shall be the greater of the following amounts, subject to the provision set forth hereinbelow:

(a) Debt and Taxes. An amount sufficient (i) to pay all debts, liabilities and obligations of the Company upon its termination and liquidation as projected to occur immediately following the sale pursuant to the Option, including, but not limited to, fees and debts to Members of the Company (or their Affiliates), and (ii) to distribute to the Members cash proceeds equal to the taxes projected to be imposed on the Members of the Company as a result of the sale of the Apartment Complex pursuant to the Option; or

(b) Fair Market Value. The fair market value of the Apartment Complex, appraised as low-income housing to the extent continuation of such use is required under the Use Restrictions, any such appraisal to be made by a licensed appraiser selected by the Company’s regular certified public accountants, who is a member of the Master Appraiser Institute and who has experience in the geographic area in which the Apartment Complex is located;

provided, however, that if prior to exercise of the Option, the Internal Revenue Service (the “**Service**”) has issued a revenue ruling or provided a private letter ruling to the Company, the applicability of which ruling shall be determined in the judgment of tax counsel to the various Members, , concluding that property of the nature and use of the Apartment Complex may be sold

under circumstances described in this Agreement at the price determined under Section 42(i)(7)(B) of the Code without limiting tax credits or deductions that would otherwise be available to the Members, then the Option Price shall be such price.

In any case, the Option Price shall be increased by an amount necessary to enable the Company to pay any outstanding and unpaid Asset Management Fee, Disposition Fee and any other debts or obligations owing to the Members, as applicable.

4. Purchase Price Under Refusal. The purchase price for the Apartment Complex pursuant to the Refusal Right shall be the lesser of (a) the amount determined under Paragraph 3(a) above, as increased pursuant to the last sentence of Paragraph 3, or (b) the third party's bona fide offer to purchase the Apartment Complex, except that, in no event shall the purchase price under the Refusal Right be less than the amount set forth in Section 42(i)(7) of the Code.

5. Conditions Precedent. Notwithstanding anything in this Agreement to the contrary, the Option and the Refusal Right granted hereunder shall be contingent on the following:

(a) Managing Member. Grantee shall have remained in good standing as a managing member of the Managing Member of the Company without the occurrence of any event described in Section 4.5(a)(iii) of the Operating Agreement after giving effect to the curative provisions applicable thereto; and

(b) Regulatory Agreement. Either (i) the Regulatory Agreement shall have been entered into and remains in full force and effect, or (ii) if the Regulatory Agreement is no longer in effect due to reasons other than a default thereunder by the Company, such Use Restrictions shall have remained in effect as to the Apartment Complex by other means.

If any or all of such conditions precedent have not been met, the Option and the Refusal Right shall not be exercisable. Upon any of the events terminating the Option or the Refusal Right under this Paragraph 5, the Option and the Refusal Right shall be void and of no further force and effect.

6. Exercise of Option or Refusal Right. The Option and the Refusal Right each may be exercised by Grantee by (a) giving prior written notice of its intent to exercise the Option or the Refusal Right to the Company and each of its Members in the manner provided in the Operating Agreement and in compliance with the requirements of this Paragraph 6, and (b) complying with the contract and closing requirements of Paragraph 9 hereof. Any such notice of intent to exercise the Option shall be given during the period commencing one (1) year prior to the expiration of the Compliance Period and terminating at the end of the Option Period. Any such notice of intent to exercise the Refusal Right shall be given within ninety (90) days after Grantee has received the Company's notice of a bona fide offer pursuant to Paragraph 2 hereof. In either case, the notice of intent shall specify a closing date within one hundred twenty (120) days immediately following the date of exercise. If the foregoing requirements (including those of Paragraph 9 hereof) are not met as and when provided herein, the Option or the Refusal Right, or both, as applicable, shall expire and be of no further force or affect. Upon notice by Grantee of its intent to exercise the Option or the Refusal Right, all rights under the other shall be subordinate to the rights then being so exercised unless and until such exercise is withdrawn or discontinued, and upon the closing of any sale of the Apartment Complex pursuant to such notice shall expire and be of no further force

or effect, provided that in the event that the Option and the Refusal Right are hereafter held by different parties by reason of any permitted assignment or otherwise, Grantee in its assignment or such parties by written agreement may specify any other order of priority consistent with the other terms and conditions of this Agreement.

7. Determination of Price. Upon notice by Grantee of its intent to exercise the Option or the Refusal Right, the Company and Grantee shall exercise best efforts in good faith to agree on the purchase price for the Apartment Complex in accordance with Paragraphs 3 and 4 hereof. Any such agreement shall be subject to the prior written consent of the Members, which shall not be withheld as to any purchase price determined properly in accordance with this Agreement. If the parties fail to agree or the Members fail to consent, then the purchase price shall be determined by arbitration. In the event Grantee for any reason withdraws or discontinues its exercise of the Option or the Refusal Right, it shall pay any and all expenses of accounting, appraisal, and arbitration incurred in the determination of the purchase price and any expenses incurred in the preparation of a purchase contract as provided hereinbelow, including without limitation reasonable legal fees of the Company and the Members in connection with any such arbitration and contract.

8. Arbitration. In the event the purchase price for the Apartment Complex is to be determined by arbitration, or in the event of any other dispute hereunder, each of Grantee and any other Members of the Company who are in disagreement on the amount of the purchase price shall exercise best efforts in good faith to agree on a single arbitrator who is experienced in the valuation of low-income rental housing to act hereunder. Such arbitrator shall conduct proceedings in the geographic area in which the Apartment Complex is located, according to such procedures as the arbitrator shall designate, provided that they are fair and do not violate the Uniform Arbitration Act if and as adopted by the state in which the Apartment Complex is located or any similar act that may apply. In the absence of an agreement by such parties on a single arbitrator or on any other method of arbitration, such dispute shall be submitted for arbitration in accordance with the applicable rules of the American Arbitration Association.

In any event, the arbitrator(s) appointed hereunder shall have all of the jurisdiction and powers of courts of law and equity in civil matters. In the event any accountant's or appraiser's determination under Paragraph 3 or 4 hereof is in dispute, the arbitrators shall have the right to appoint an independent accountant or appraiser, as applicable, to assist in rendering a decision on the purchase price, but the arbitrators shall also consider any such determinations submitted by any party to the arbitration proceedings. The parties to such arbitration hereby agree to accept any decision or award made by the arbitrators in accordance with arbitration proceedings conducted pursuant hereto, and the same shall be final and binding on such parties. Any such decision or award may be enforced, and judgment thereon may be entered, by any court of competent jurisdiction. All fees and expenses of such arbitration proceedings, including both those of the arbitrator(s) and reasonable attorneys' fees of counsel for the respective parties to arbitration, shall be paid by the party or parties against whom the decision or award is rendered or as may otherwise be determined to be equitable by the arbitrators. In the event any disagreeing party fails to appoint an arbitrator who is able and willing to serve hereunder within twenty (20) days after any demand for arbitration by any other party or fails to proceed in good faith with arbitration proceedings hereunder, the other parties may each at its option take any action available to them in law or equity in any court of competent jurisdiction.

9. Contract and Closing. Upon determination of the purchase price, the Company and Grantee shall enter into a written contract for the purchase and sale of the Apartment Complex in accordance with this Agreement and containing such other terms and conditions as are standard and customary for similar commercial transactions in the geographic area which the Apartment Complex is located, providing for a closing not later than the date specified in Grantee's notice of intent to exercise the Option or the Refusal Right, as applicable, or ninety (90) days after the purchase price has been determined, whichever is later. In the absence of any such contract, this Agreement shall be specifically enforceable upon the exercise of the Option or the Refusal Right, as applicable. The purchase and sale hereunder shall be closed through a deed-and-money escrow with the title insurer for the Apartment Complex or another mutually acceptable title company.

10. Assignment. Grantee may assign all or any of its rights under this Agreement to (a) a qualified nonprofit organization, as defined in Section 42(h)(5)(C) of the code, (b) a government agency, or (c) a tenant organization (in cooperative form or otherwise) or resident management corporation of the Apartment Complex (each a "**Permitted Assignee**") that demonstrates its ability and willingness to maintain the Apartment Complex as low-income housing in accordance with the Use Restrictions, in any case subject to the prior written consent of the Members, and subject in any event to the conditions precedent to the Refusal Right and the Option set forth herein. Prior to any assignment or proposed assignment of its rights hereunder, Grantee shall give written notice thereof to the Company and the Members. Upon any permitted assignment hereunder, references in this Agreement to Grantee shall mean the Permitted Assignee where the context so requires, subject to all applicable conditions to the effectiveness of the rights granted under this Agreement and so assigned. No assignment of Grantee's rights hereunder shall be effective unless and until the Permitted Assignee enters into a written agreement accepting the assignment and assuming all of Grantee's obligations under this Agreement and copies of such written agreement are delivered to the Company and the Members. Except as specifically permitted herein, Grantee's rights hereunder shall not be assignable.

11. Reformation as a Redemption. Notwithstanding the foregoing, Grantee, as the sole member of the Managing Member of the Company, shall have the option to reform this Agreement to provide for a redemption by the Company of the Members' Interests in the Company in lieu of a purchase by Grantee of the Apartment Complex; provided, however, that the economic, tax and material consequences of the transaction for the Members shall not be altered thereby, and that any such reformation shall require execution by the Company and any other Managing Member of all documentation and the prior written consent of the Members to all documentation. In connection with any such redemption, Grantee shall be entitled to appoint a substitute non-managing member to the Company if necessary for the purpose of causing the Company to have a minimum of two members at all times.

12. Miscellaneous. This Agreement shall be liberally construed in accordance with the laws of the State of Virginia in order to effectuate the purposes of this Agreement. This Agreement may be executed in counterparts or counterpart signature pages, which together shall constitute a single agreement.

[Signatures begin on the next page.]

IN WITNESS WHEREOF, the parties have executed this document as of the date first set forth hereinabove.

COMPANY:

WESTSIDE VILLAGE RENEWAL LLC,  
a Virginia limited liability company

By: Westside Village Manager LLC,  
its managing member

By: Huntington Housing, Inc.,  
its manager

By:   
Todd Travis, President

MANAGING MEMBER:

WESTSIDE VILLAGE MANAGER LLC,  
a Virginia limited liability company

By: Huntington Housing, Inc.,  
its manager

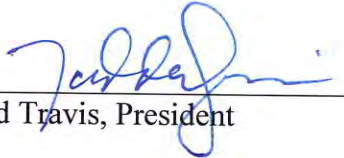
By:   
Todd Travis, President

GRANTEE:

HUNTINGTON HOUSING, INC.,  
a Maryland nonstock corporation

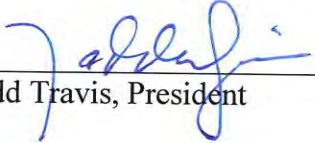
By:   
Todd Travis, President



Acknowledgments

STATE OF Maryland )  
 ) SS.  
COUNTY OF Montgomery )

On March 16, 2020, before me, the undersigned, personally appeared Todd Travis, personally known to me (or proved to me on the basis of satisfactory evidence) to be the person whose name is subscribed to the within instrument and acknowledged to me that she executed the same in her authorized capacity, and that by her signatures on the instrument the person or the entity upon behalf of which the person acted, executed the instrument.

WITNESS my hand and official seal.

  
Signature  
(notarial seal)

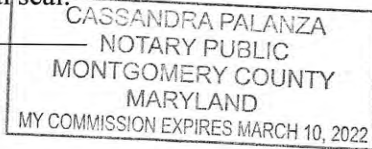

STATE OF Maryland )  
 ) SS.  
COUNTY OF Montgomery )

On MARCH 16, 2020, before me, the undersigned, personally appeared Todd Travis, personally known to me (or proved to me on the basis of satisfactory evidence) to be the person whose name is subscribed to the within instrument and acknowledged to me that she executed the same in her authorized capacity, and that by her signatures on the instrument the person or the entity upon behalf of which the person acted, executed the instrument.

WITNESS my hand and official seal.

  
Signature  
(notarial seal)

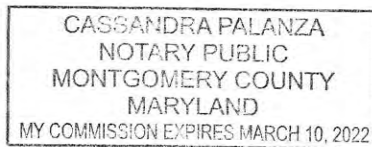

## **EXHIBIT A**

### **Legal Description of Property**

All that certain tract or parcel of land, with improvements and appurtenances thereunto belonging, lying and being situated in Banister District of Halifax County, Virginia, fronting 729.32 feet on the westerly boundary of Virginia State Highway No. 654, and described more particularly as follows:

Beginning at a new iron pipe in the westerly margin of the proposed Westside Drive, thence along the westerly margin of Virginia State Highway No. 654 S.  $50^{\circ} 48' 18''$  E 729.32 feet to an existing iron pipe in the westerly margin of Virginia State Highway No. 654 and the northern line of property now or formerly owned by James Martin; thence along the northern line of the Martin Property S.  $65^{\circ} 02' 50''$  W. 673.50 feet to a new iron pipe, a corner in Martin's northern line; thence leaving

Martin's northern line along a new line N.  $36^{\circ} 04' 25''$  W. 425.45 feet to a new iron; thence along a new line N.  $53^{\circ} 55' 35''$  E. 34.30 feet to a new iron pipe; thence along a new line N.  $15^{\circ} 46' 45''$  W. 159.93 feet to a new iron pipe in the southern margin of the proposed Westside Drive; thence along the southern margin of the proposed Westside Drive N.  $53^{\circ} 55' 35''$

E. 385.63 feet to a new iron pipe at the point of beginning, and containing 8 acres or 348.480 square feet.

W

(Reserved)

# **Westside Village Acceptable Use Policy**

Please read this acceptable use policy carefully before using the Westside Village wireless network.

Services provided by us may only be used for lawful purposes. You agree to comply with all applicable laws, rules and regulations in connection with your use of the services. Any material or conduct that in our judgment violates this policy in any manner may result in suspension or termination of the services or removal of user's account with or without notice.

## **Prohibited use**

You may not use the services to publish content or engage in activity that is illegal under applicable law, that is harmful to others, or that would subject us to liability, including, without limitation, in connection with any of the following, each of which is prohibited under this AUP:

- Phishing or engaging in identity theft
- Distributing computer viruses, worms, Trojan horses or other malicious code
- Distributing pornography or adult related content or offering any escort services
- Promoting or facilitating violence or terrorist activities
- Infringing the intellectual property or other proprietary rights of others

## **Enforcement**

Your services may be suspended or terminated with or without notice upon any violation of this policy. Any violations may result in the immediate suspension or termination of your account.

## **Reporting violations**

To report a violation of this policy, please contact us.

We reserve the right to change this policy at any given time, of which you will be promptly updated. If you want to make sure that you are up to date with the latest changes, we advise you to frequently visit this page.



## Resident Internet Policy Acknowledgement Form

I, \_\_\_\_\_, acknowledge that I have reviewed the Westside Village Acceptable Use Policy and the Office of the Attorney General Internet Safety Package. I agree to abide by the rules and procedures outlined in the policy.

\_\_\_\_\_

Resident Signature

\_\_\_\_\_

Date





# Internet Safety

Playing it safe while playing online





Hi there kids! I am Charlie Cardinal and this is Speedy the Crime Fighting Hamster. We are here to introduce you to the basics of Internet Safety and some of the villains you need to watch out for. There are some bad characters out there, so you have to protect yourself. Your parents won't always be there to watch out for you, so stay sharp, learn all you can, and stay safe!



# Privacy & Personal Information



Privacy is being able to keep things secret or hidden from others.

Personal Information is information about you or your family such as your address, a social security number, your parent's bank account, or how much money they have.

Criminals love to get people's personal information because they can pretend to be you, or use your money to buy things.

They can also make money off of your information by selling it to others. Companies or other criminals will use your info to send you junk mail or spam emails.

Criminals learning your address can be very bad. They may break in and steal from you. Protect your safety and your belongings, by keeping your information a secret.

These bad people may even use your personal information to trick someone else in your circle of friends and family. People sometimes tell criminals things that they shouldn't if they think that they are communicating with someone they know.



Think before you click



Do you know who sent that email?



# Passwords

One of the most important things you need to learn is how to create strong passwords. A password is a code you type in to let the computer know it is really you.

Having an easy to guess password could allow someone to snoop around in your private information.

The way to make your password strong is to never use your name or your birthday. Use something hard to guess, but easy for you to remember. Make your password at least 8 characters long, and mixing numbers, symbols, and upper and lower case letters makes the password strong just like Speedy. Avoid using the same password over and over. That way if they do figure out your password, they only gain access to one account. And never leave your passwords written down where someone can find it.



A great tool online that creates kid friendly passwords is the website, [www.dinopass.com](http://www.dinopass.com)

# Spam



Spam is basically email that you receive from different companies or strangers that you did not sign up for. Most times it isn't from real companies and usually the sender is up to no good.

Spam emails can sometimes be a phishing scam. Phishing emails are emails that look like it is from some trusted source. A place like your bank, the IRS where taxes are collected, or some other business you shop with often. They make their email look like it is the real thing with logos, and they put links in the email baiting you to click them. Once you click the link, you could be launching a program that can damage your computer in some way or collect your personal information.

Spam emails can also use winning a sweepstakes or some other type prize to trick you into trusting the email source. After they hook you in, they inform you that to collect your prize, you must give them your credit card number.

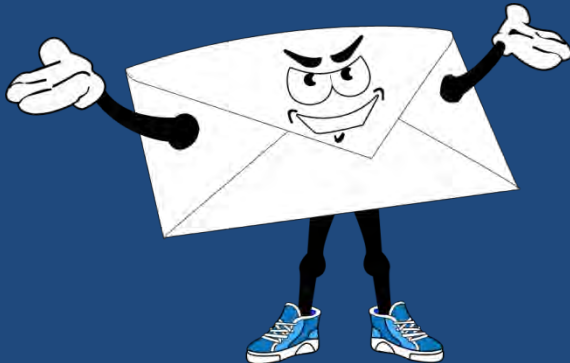

How do you know it is spam?

Spam emails typically have a bunch of spelling and grammar errors or a mention of someone you don't know in the subject line. Don't Open It! Delete those emails right away.



# Malware



Malware is a program written with the intent to harm your computer in some way.

Programs such as this, may be waiting for you to do something(a trigger), so that it can run. This could be the clicking of the link or opening an email attachment.

When searching for free downloads online, be very careful. There are a lot of sites out there trying to trick you. They will pay to make their site get returned at the top of the list of search results. Then when you access the page, they use blinking buttons to trick you to click. The result of clicking usually ends up being your computer loaded up with malware.

Once your machine is infected, it can change browser settings, create unusual popup ads on your computer and then pass the malware on to someone else.



Spyware is a program that gets onto your computer through a download or a virus and it gathers information about you and sends this back to its creator.

Some of the types of information spyware might send back to home base is email addresses of you or your contacts, passwords, account numbers, and credit card numbers.

Some spyware out there records how you use your computer and what you search for online.

# Adware

Adware is software that you are allowed to use by the author because of the advertisements that pop up occasionally during the game. Many of these type games you will find in the form of apps on your phone or devices.

Through the addition of advertisements, the developer gains some income that may supplement a discount to the user, sometimes making the software free.

Often after using the product with the ads, a consumer will purchase the software to get rid of the ads.

<http://www.pctools.com/security-news/what-is-adware-and-spyware/>



# Trojan Horse

The name for the Trojan Horse virus was derived from tale of the Trojan Horse constructed by the Greeks to gain access to the city of Troy. The wooden horse was left at the gates as an offering to Athena. The horse was then wheeled into the city and out came Greek fighters hiding inside. <http://www.britannica.com/topic/Trojan-horse>

A Trojan horse virus is a form of malware that is dressed up as something interesting or software from a source we are familiar with. The purpose is to trick the person into installing it. This allows the creator of the Trojan to do damage to data or software on your computer. They also will set up a 'back door' or access point that allows them to access your system.

Trojan viruses don't spread by infecting other files and they cannot duplicate themselves.

<http://www.webopedia.com/DidYouKnow/Internet/virus.asp>

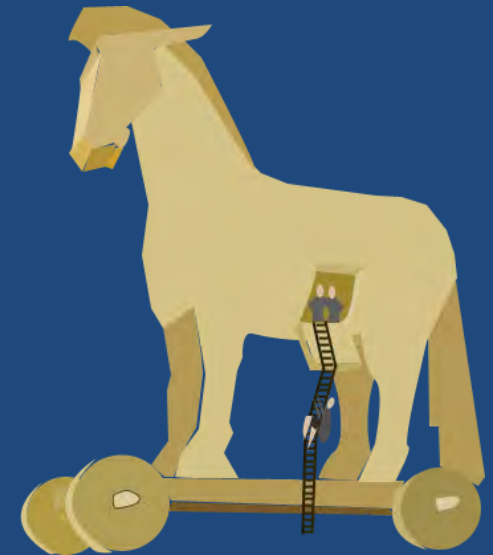



# Worms

Worms are malware that can duplicate itself and spread to other computers. Worms always do something bad, even if it is just slowing things down.

Worms will frequently set up the ability for computers to be taken over by the worm's author by creating backdoors on the host computer. These computers are then called a "zombie computer". "Zombie computers" can be used to send out spam or as a shield to hide the web address of people who want to do bad things.

<http://www.webopedia.com/TERM/Z/zombie.html>





# Virus

A virus is a small program that is created to spread from one computer to the next and to mess up the way your computer works.

Many times viruses hop from computer to computer via email attachments or messages. They can also hide in funny pictures(memes), e-cards, or other desirable file attachments. It can also be sent through an instant message.

A virus can corrupt your data, or worse, delete it. It can also email copies of itself to your friends.

Keeping your anti-virus software up to date is key to protecting against the latest viruses and other security threats.

<https://www.microsoft.com/security/pc-security/virus-whatis.aspx>

# Social Media



Privacy settings on social media accounts are set up as public when you first get one. Unless you want everyone to be able to look at all of your photos and other private stuff, you must go into your account settings and change this.

Something to remember is whatever you post and say on your page can be shared by your friends. Think about what you post online, BEFORE you do it. What you post, could be seen by anyone at any time depending on your settings and the friends you keep. Because we can take pictures of our screens, there is really no setting that can protect you. Think twice about what you are sharing with others, so there are no regrets later.

Make sure you know the people that you accept friend requests from. Sometimes people try to friend you to hack your Facebook account or access your contacts. Once you are hacked they will send out strange messages or friend requests to your contacts. Protect your friends and yourself by being cautious with friends and creating strong passwords for your social media accounts.

# Geotagging



Geotagging is the bit of data that your electronic device packages with your picture that has information about where the picture was taken. This is something that can be turned on and off in your device and typically comes turned on until you change the setting.

When your photo is geotagged, this gives people information about your location. Letting outsiders know where you are, can allow them to plan to steal your belongings or vandalize your home.

Consider if you post a photo every Wednesday in your outfit ready to walk to ball practice and geotagging is turned on. This shows you have a routine and gives a rough area you will be in. A predator could come and take you away.

Another issue with allowing the geotagging to occur is you don't have control of your own privacy. Everyone does not need to know where you are all of the time, keep this information private.

<http://www.nytimes.com/2010/08/13/technology/personaltech>



# Be Careful of What You Say!



**Defamation:** Defamation is the blanket word used for all types of untrue statements made about others. [Definition of Defamation on Law.com](#)

**Slander:** When someone orally tells one or more people an untruth about someone, which will harm the reputation of the person it is about. It is not slander if the untruth is in writing of some sort or if it is broadcast through television or radio.

[Definition of Slander on Law.com](#)

**Libel:** This is where someone publishes to print(including pictures), written word, online posts, blogs, articles, or broadcast through radio, television, or film, an untruth about another which will do harm to the person's reputation. [Definition of Libel on Law.com](#)



# Be Careful of What You Say!



Much of the things people post online may get ignored, and you may get lucky and avoid legal action. But, when someone gets angry and files a lawsuit it can cause a major headache and possibly hit you hard in the wallet.

You might think you should have a right to openly complain about a company and their bad service or lousy product. Well when it comes to this, it is not always that simple. You can get sued for this and even if the judge agrees with you, you still have to pay for a defense attorney. Think twice and make sure that whatever you have to say is worth any headache you may have pop up later.

<http://ideas.time.com/2013/01/07/yelp-reviewers-beware-you-can-get-sued/>

On social media, people get into the habit of letting their emotions get the better of them and they end up speaking their minds about others online. When that person feels that this damages their character, they may opt to sue the other person for defamation. Even if their case is not successful, the stress, money, and time that you spend defending yourself is not worth it. To read more about defamatory social media posts, [click here](#).

# Stranger Danger Online



When you think of being on your computer or other electronic device in your own home, you probably think you are safe. Your mom is in the next room, what could happen?

Well there are people online that are up to no good. They go in chat rooms and pop up on your instant messenger, looking for someone to “groom”.

What is grooming you say? Well, grooming is when a stranger (can be any age) finds someone they are interested in, usually a minor. They act really nice and maybe they pretend they are much younger than they really are, like they are a kid just like you. Then they try to get you to like them and to trust them. They may ask you not to tell anyone you are talking to them. This is not okay and is a warning sign of a possible groomer.

# How to Protect Yourself in Online Chats

- Choose chat sites designed for kids, such as [www.kidzworld.com](http://www.kidzworld.com). Kidzworld is moderated and its aim is to protect kids from unwanted requests and online bullying.
- Beware of people you don't know. If they are asking too many questions or being too friendly they may be up to no good.
- If someone asks you to send them a picture or sends you a picture or video that is inappropriate, tell an adult or report them to the site moderators.
- Don't give out personal information to strangers online
- Don't tell strangers where you live or give them your telephone number
- Don't send strangers pictures of you or others
- If you are being bullied or threatened online, tell an adult or someone you trust







# Cyberbullying

- Cyberbullying is the **willful and repeated harm** inflicted through the use of computers, cell phones, and other electronic devices.
- Using PhotoShop or other tools to create harassing images.
- Posting jokes about another person on the internet
- Using the internet to entice a group to physically harm another person.
- Making threats online using IM, email, social networking sites, or other electronic devices.



# Consequences of Cyberbullying

Anything that you write, pictures that you post, or videos that you upload can be used by your school to suspend you.

College students have been removed from their athletic teams and lost college funding for writing negative comments about their coach.

When applying to colleges, they will search online to see what kind of person you are. They can deny you access if they don't like what they find.

When businesses are looking at people to hire for a job they will many times use social media to see what kind of person they are. Mean or inappropriate type posts can prevent you from getting the job you desire.

Cyberbullying can also be considered a crime and participating in this type of behavior can land you in big trouble.

# Consequences of Cyberbullying

- § 18.2-152.7:1. Harassment by Computer; Penalty makes cyberbullying a crime.
- Carries a \$2500 fine and punishable by up to **12 months in prison.**

There are many websites designed to inform and decrease the number of bullying cases we see each year. The U.S. Department of Health and Human Services has created a website with lots of resources to help combat bullying of all kinds - [www.stopbullying.gov](http://www.stopbullying.gov)

If you experience cyberbullying or witness it, tell someone such as a school counselor, teacher, or a parent.





# The Effects of Cyberbullying

- Victims feel depressed, sad, angry, and frustrated.
- Victims become afraid and/or embarrassed to attend school.
- Can lead to low self-worth, family problems, academic problems, school violence, and bad behavior.
- Victims can also develop thoughts of killing themselves and possibly act on these feelings.
- There are no positive effects of cyberbullying, only pain and suffering for the victims.
- The affects of being bullied can affect the victim into adulthood and prevent them from being all they can be in the future.



# Dealing with Cyberbullying

- Never do the same thing back, 2 wrongs don't make a right
- Tell them to stop
- Block their access to you
- Report it to the site you are on such as Facebook or Twitter
- NEVER pass along messages from cyberbullies, stop the spread of this behavior
- Set up privacy controls and keep the bully out of your friends list
- Don't be a cyberbully yourself
- If you witness someone getting bullied, tell someone so it can be stopped. Many times the person being bullied won't tell out of fear.
- Spread the word that bullying is not cool
- Don't laugh or encourage the bully, it is not funny and it can lead to major trouble for the person doing the bullying.



# About Sexting



“Sexting” is when someone sends or receives sexually explicit or non-PG Rated pictures or video electronically, mainly via cell phones or tablets.

The numbers on how many teens say that they have sent/posted nude or semi-nude pictures or videos of themselves is upsetting.

20% of teens between 13 to 19 years of age have engaged in sexting.

22% of teen girls

18% of teen boys

11% of teen girls between 13 to 16 years of age have engaged in sexting.

Did you know that if you forward a picture of a sexual or nude photo of someone underage, you are as responsible for the image as the original sender?? You can be charged with a crime.

Many teens don't realize that if you send a picture of yourself that is inappropriate and that picture ends up online, it could be there forever. You can never fully delete things that end up on the web.



# About Sexting



There is no age minimum that protects young people from getting charged with a sexual offense.

Something that you think is okay or just a joke, might land you in a ton of trouble. For example, you might take a picture of your friend naked to embarrass them, but if they are under the age of 18, this is considered production of child pornography.

If you are sent something inappropriate, do not share it and don't delete it. Tell an adult immediately. You may feel like you are getting your friend into trouble, but you are protecting yourself and you are protecting them. They may not be thinking about the consequences or the effect this behavior can have on their future.

Anyone that gets convicted of a sex offense, will have to register as a sex offender. Sex offenders have to keep their address updated and keep a current photo with the police. The information goes on the sex offender registry where anyone can go and see your picture and where you live online.

**REMEMBER:** You can't control what other people do with your photos. Even if you think you are sending it to someone you can trust, they may end up surprising you. You can't trust anyone with something as private as that. Don't Do It!

# Legal Consequences of Sexting

- The Virginia Department of Education has an excellent resource with real life examples of the consequences of sexting that can be found [here](#).
- The Attorney General's Virginia Rules website is designed to give Virginia Youth information on all the laws in the state. [Virginia Rules](#) has extensive information on sexting and other internet security risks.
- This article in The Virginian-Pilot tells a story of five Virginia teens getting charged with felonies for sexting and being in possession of sexually explicit photos of a minor, read more about it [here](#).



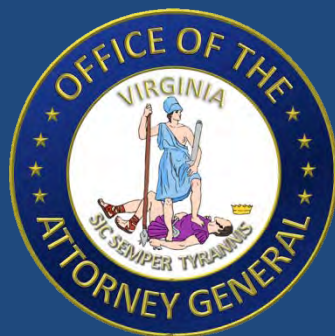

Information Provided By:  
Office of the Attorney  
General

202 North Ninth Street  
Richmond, Virginia 23219

(804) 786-2071

[www.ag.virginia.gov](http://www.ag.virginia.gov)

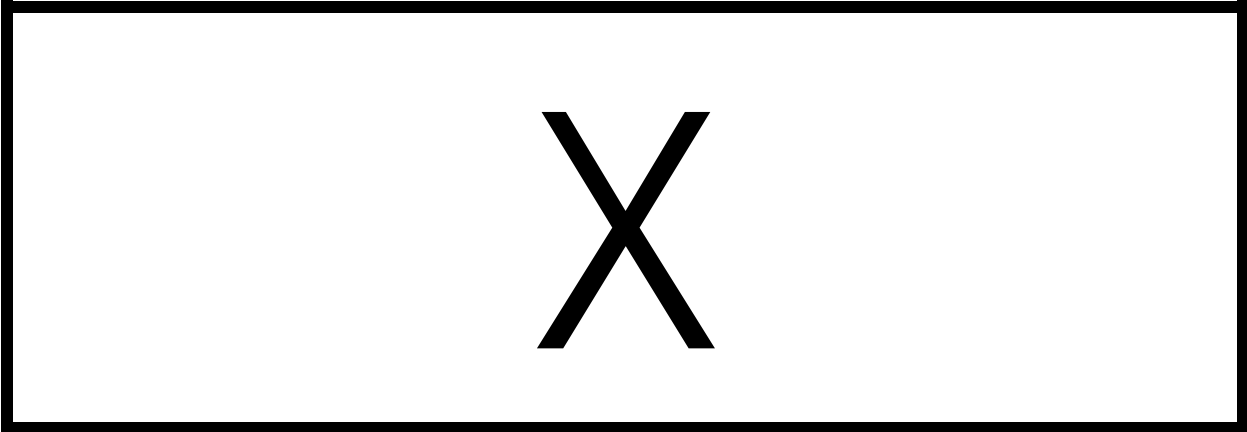

X

# Marketing Plan

For units meeting accessibility requirements of HUD section

504

# *Westside Village Apartments*

## *Marketing Plan for Units Which Conform to Section 504 of the Rehabilitation Act*

This Marketing Plan for Units Which Conform to Section 504 of the Rehabilitation Act (the “Marketing Plan”) has been designed to convey to current and potential residents with disabilities that Westside Village Apartments will be a rental housing experience, with a commitment to excellent management and resident service, as well as an expectation of resident responsibility. Therefore, the majority of this plan will address ways in which property management will endeavor to secure qualified tenants, ensure quality tenancy, and effective management and maintenance of the property.

The Management Agent will be responsible for the management of Westside Village Apartments. Dalcour Management Incorporated (Dalcour), the Management Agent, will be responsible for all of the traditional management functions, including rent collection, maintenance, record keeping, reports, development of budgets, and monitoring resident income qualifications. Additionally, Dalcour will be responsible for the development and management of community and resident services program.

### **I. Affirmative Marketing**

Dalcour is pledged to the letter and the spirit of the U.S. policy of the achievement of equal housing opportunity throughout the Nation and will actively promote fair housing in the development and marketing of this project. Dalcour, its Officers, Directors and employees will not discriminate on the basis of race, creed, color, sex, religion, familial status, elderliness, disability or sexual orientation in its programs or housing. They will also comply with all provisions of the Fair Housing Act (42 U.S.C. 3600, et. Seq.).

Any employee who has discriminated in the acceptance of a resident will be subject to immediate dismissal. All persons who contact the office will be treated impartially and equally with the only qualification necessary for application acceptance being income and credit, and conformity with the requirements of the Section 8 Program and Tax Credit programs. All interested parties will be provided a copy of the apartment brochure. Any resident who has questions not answered by the housing staff will be referred to the Regional Manager or the President of Dalcour.

### **II. Developmental Disability Preference**

As part of the LIHTC Application, the Owner has elected to provide a first preference on its waiting list for persons with a developmental disability for the greater of 5 or 10% of the units. Dalcour will work with the Virginia Department of Behavior Health & Development Services (DBHDS) for referrals for these residents. As part of the rental application, DBHDS will be issuing letters to individuals qualifying in this target population and will be kept by as part of each resident’s file.

### **III. Marketing and Outreach**

Locating people with disabilities to occupy the units which conform to the requirements of Section 504 of the Rehabilitation Act will be accomplished as follows:

#### **1. Networking**

Dalcor will contact local centers for independent living and disability services boards and other service organizations via phone and printed communication. The property is currently and will continue to be listed in **virginiahousingsearch.com** for the duration of the compliance period. The listing on **virginiahousingsearch.com** will provide information on the amenities available for the Target Population. The contacts will include the following organizations:

- Central Virginia Community Services (434-847-8050)
- Department of Rehabilitative Services (434-947-6721)
- Halifax Developmental Day Support (434-572-2971)
- Virginia Board for People with Disabilities (804-786-0016)
- Virginia Vocational and Rehabilitation Agency (804-662-7000)
- Centers for Independent Living
  - Disability Resource Center (540-373-2559)
  - Access Independence (540-662-4452)
- Virginia Rehab Association (804-662-7075)
- South Boston Department for Aging and Rehabilitative Services (434-572-8064)

## **2. Print Media**

Print media sources will also be identified in the South Boston area that cater to people with disabilities as well as the public at large. These sources may include, but are not limited to, rental magazines such as the Apartment Shoppers Guide, Apartments for Rent, local newspapers, etc. All advertising materials related to the project will contain the Equal Housing Opportunity logotype, slogan or statement, in compliance with the Fair Housing Act, as well as the fact the units for people with disabilities are available.

## **3. Resident Referrals**

An effective Resident Referral program will be set up, in which current residents are rewarded for referring friends, coworkers, and others who may have disabilities to the property. These referrals are generally the best form of advertising as it attracts friends who will want to reside together, thus binding the community. ***Residents will be offered incentives, to be determined, for referring qualified applicants who rent at the property.*** Flyers will be distributed to residents along with the project newsletter announcing the tenant referral program.

## **4. Marketing Materials**

Additional marketing materials are needed in order to further support the specific marketing effort to people with disabilities. All printed marketing materials will include the EHO logo. The marketing will also emphasize the physical and administrative compliance with Americans with Disabilities Act.

These marketing materials include:

- **Brochures** –A simple, two color brochures can be produced at low cost which will effectively sell the apartments and community. This brochure will include the floor plans, a listing of features and amenities. The floor plans should be printed in as large a format as possible.
- **Flyers** - As mentioned earlier, a flyer campaign can be used effectively to market the community. Each flyer should incorporate graphics as well as a small amount of copy and should be designed to generate traffic.
- **Resident Referral** - The least expensive form of advertising is through Resident Referrals. A flyer should be created and distributed to all residents. (\$50 per referral, paid upon move in). In addition to being distributed to all residents, the referral flyer should be left in the Management office and should be included in the move in packet. (People are most inclined to refer their friends in the first few weeks of their tenancy.) The flyers should be changed several times each year to reflect the season or any type of special referral program.

#### **IV. Public and Community Relations**

Equal Housing Opportunity promotions - all Site Signage containing the EHO logo and Fair Housing posters are displayed in English and Spanish in the Rental Office. Edgewood encourages and supports an affirmative marketing program in which there are no barriers to obtaining housing because of race, color, religion, national origin, sex, elderliness, marital status, personal appearance, sexual orientation, family responsibilities, physical or mental handicap, political affiliation, source of income, or place of residence or business.

Additionally, a public relations program will be instituted to create a strong relationship between management and local disability organizations, neighborhood civic organizations, churches, mosques, and synagogues, city officials, and other sources of potential qualified residents still to be identified.

#### **V. Tenant Selection and Orientation**

The first contact with the management operations is an important one in attracting qualified residents; therefore the management/leasing offices should convey a sense of professionalism, efficiency, and cleanliness. The management/leasing office is designed to provide a professional leasing atmosphere, with space set aside specifically for resident interviews and application assistance. The leasing interviews will be used to emphasize the respect afforded to the resident and the responsibilities which the resident will be expected to assume.

Times of Operation - the Management Office will be open Monday through Friday from 8:30 A.M. to 4:30 P.M. Applicants will be processed at the Management Office in accordance with approved criteria. Move-in process and orientation to property - applicants meet with the Housing Manager or designated staff to discuss programs available on the property and will be supplied relevant information to assist them in their move.

On-site staff will check previous landlord and personal references, verify income, perform criminal/sex offender and credit background checks for each application taken. New tenants will be given an orientation to the property including a review of the rules and regulations, information on the area, proper use of appliances, move-out procedures, maintenance procedures, rent payment procedures, energy conservation, grievance procedures and a review of the Lease documents.

#### **Unit Availability**

Units must be held vacant for 60 days during which ongoing marketing will be documented. If a qualified household including a person with a disability is not located in that timeframe, the Management

Agent will submit the evidence of marketing to VHDA's Program Compliance Officer and request approval to rent the unit to any income-qualified household. If the request is approved, the lease will contain a provision that the household must move to a vacant unit if a household including a person with a disability applies for the unit. The move will be paid for by the owner.

### **Tenant Selection Criteria**

Tenant Selection will include maximum income standards under the Low-Income Tax Credit and Section 8 programs. New tenants will be given an orientation to the property including a review of the rules and regulations, information on the area, proper use of appliances, move-out procedures, maintenance procedures, rent payment procedures, energy conservation, grievance procedures and a review of the Lease documents.

### **Application Processing**

Application processing will be done by the housing staff at the Management Office, well versed in Fair Credit Law. As stated before, the processing will include a review of prior landlord references, personal references, criminal/sex offender and credit reporting and income verification. The on-site staff will make further review for inaccuracies in the application.

The annual income and family composition are the key factors for determining eligibility. However, the Property Manager will also use the following criteria in selecting applicants for occupancy:

- Applicants must be individuals, not agencies or groups.
- Applicants must meet the current eligibility income limits for tax credits and any other program requirements.

Note- If the applicant's denial is based upon a credit report, the applicant will be advised of the source of the credit report in accordance with the Federal Fair Reporting Act. Guidelines published by the Federal Trade Commission suggest that apartment managers fall under the provisions of the Act and are obligated to advise the person refused an apartment for credit reasons, the name and address of the credit reporting firm in writing. The credit report will not be shown to the applicant, nor will specific information be revealed.

- We will process the Rental Applications through a credit bureau to determine the credit worthiness of each applicant. If the score is below your threshold, but you have determined the applicant has no bad credit *and* no negative rental history *and* no criminal history and enough income to qualify, then you can conditionally approve the application after you have contacted the prior landlord. In these cases, the application must be reviewed by the Regional Manager before final approval.
- We will process the Rental Application through a credit bureau to determine any possible criminal conduct. Convictions will be considered, regardless of whether "adjudication" was withheld. A criminal background check will be used as part of the qualifying criteria. An applicant will automatically be denied if;
  - There is a conviction for the manufacture, sale, distribution, or possession with the intent to manufacture, sell or distribute a controlled substance within three years for a misdemeanor and seven years for a felony.
  - There is evidence in the criminal history that reveals that the applicant has developed a pattern of criminal behavior, and such behavior presents a real or potential threat to residents and/or property.

- The application will be suspended if an applicant or member of the applicant's family has been arrested for a crime but has not yet been tried. The application will be reconsidered, within the above guidelines, after such legal proceedings have been concluded.
- Applicants must provide complete and accurate verification of all income of all family members. The household's annual income may not exceed the applicable limit and the household must meet the subsidy or assisted Income Limits as established for the area in which Burton Creek Apartments is located. The annual income is compared to the area's Income Limits to determine eligibility.
  - Family composition must be compatible for units available on the property.
  - Applicants must receive satisfactory referrals from all previous Landlords.
  - Applicants must provide verification of full-time student status for all individuals listed on the application as full-time student for tax credit units.
  - Applicants must not receive a poor credit rating from the Credit Bureau and other credit reporting agencies and must demonstrate an ability to pay rent on time.
  - Applicants must provide a doctor's statement and/or other proof of any handicap or disability if required.
  - Applicants must provide a birth certificate or other acceptable HUD approved forms of documentation for all household members.
  - Applicants must fill out the Application for Lease and all verification forms truthfully.
  - Applicants must provide all information required by current Federal regulations and policies.
  - Applicants must have the demonstrated ability to maintain acceptable housekeeping standards.
  - Applicants must have the demonstrated ability to pay the rent for the proposed unit, without spending a disproportionate amount of income for rent.
  - Applicants must meet current Federal program eligibility requirements for tax credits and any other programs.
  - Preference will be given to those households whose family members are handicapped or disabled for housing in the units specifically designated for the handicapped or disabled.
  - Applicants who meet the above criteria will be placed on a waiting list based on the date and time of their application. If an applicant turns down a unit for any reason, the applicant will be moved to the bottom of the waiting list. If the applicant turns down a unit for any reason a second time, the applicant will be removed from the waiting list.







≡ Menu

Westside Village  
2150 Sinai Road - Building 18 - South Boston, VA 24592



↓ Report an Issue ↓

Income Restricted ⌵

**\$0 - \$450**  
Income Based Rent ⌵

Deposit \$50 - \$450

Waiting List

One Year Lease

Utilities Included: Trash Pickup

Application Fee: \$19 Per Adult ⌵

Credit Check ⌵ : **YES** Criminal Check ⌵ : **YES**

**1 Bed • 1 Bath • Apartments**

Built 1978 (approx.)

Contact Westside Manager  
T.M. Associates Inc., Property Manager or Realtor



Phone [434-572-2093](tel:434-572-2093)



this listing has  
no pictures 



### Basic Features

Pets	Not Allowed 
Smoking	Allowed 
Trash Service	Yes
School District	Halifax County Public Schools
Other Features	Lawn Care Included



## Appliances

Microwave	None
Refrigerator / Freezer	Freezer On Top
Clothes Washer	No Hookup
Clothes Dryer	No Hookup
Laundry Room / Facility	Accessible With Front Controls (On Site) 

## Utilities

Air Conditioner	None
Heating Type	Electric
Water Heater	Electric
High-speed Internet Ready	Yes
Cable Ready	Yes

## Specialized Information

Listing ID	527954
Familiar with Section 8 process	No 
Tax Credit Property	Yes 
Seniors Only	No 

## Accessibility

Counter/Vanity	Standard Height Counters and Vanity
Door/Faucet Handles	Unknown

## Kitchen & Bath Accessibility

Kitchen	Standard	<a href="#">↓ Comprehensive List ↓</a>
Bathroom	Standard	<a href="#">↓ Comprehensive List ↓</a>

## Safety

Lead-free / Passes Lead Safe Guidelines	Yes 
<a href="#">↳ Learn More</a>	<a href="#">HUD Lead Paint Guidelines</a> <a href="#">Lead Paint Disclosure Rule</a>
Fire Safety	Smoke Detector

## Parking and Entry

Parking Type	Off Street
Parking in Front of Entrance	No
Entry Location	Unknown
Unit Entry	Step(s)
Unit Minimum Door Width	Unknown

## Nearby Services

Also Nearby	Dumpsters
-------------	-----------

## Comments

Qualifiers For Sliding Scale or Income Restriction [Contact for Income Restrictions.](#)



We monitor listings, but if you see an issue, we want to hear from you!

[Read Scam Alert](#)
[Report Listing](#)

Under the [Federal Fair Housing Act of 1968](#), as amended in 1988, it is illegal to engage in discriminatory advertising based on race, color, religion, sex, familial status, disability, and national origin.

[Home](#) | [Find Housing](#) | [List Housing](#) | [Disclaimer](#) | [Privacy](#) | [Terms](#) | [About Us](#) | [Contact Us](#) | [Link To Us](#)

Sponsored by:  
[Virginia Housing Development Authority](#)

Toll-Free: 1.877.428.8844 - Toll-Free Fax: 1.866.265.7811 - TDD/TTY: 7-1-1 [ [Relay Service](#) ]

Copyright © 2020 - [Emphasys Software](#) - All rights reserved

Email: [info@socialserve.com](mailto:info@socialserve.com) - Socialserve.com - PO Box 35305 - Charlotte, NC 28235

Page Loaded: 03/06/20 13:53 (Eastern Time) - Version 4.0



Powered by [Emphasys Software](#)